

bass management controller | BMC

owner's manual

Contents

Important	Safety Instructions	Page 3
1	Philosophy and Introduction	Page 4
2	A Tour of the BMC Main I/O Unit	Page 4
3	A Tour of the BMC Remote	Page 5
4	System & Software Overview	Page 6
5	5.1 Speaker Placement	Page 7
6	5.1 System Wiring Diagram	Page 8
7	5.1 System Calibration	Page 9
8	Additional Setup Information	Page 10
9	Cable and Wiring Information	Page 10
10	Technical Information	Page 11
11	Product Dimensions	Page 11
12	Factory Service Instructions	Page 12
13	Contact Details	Page 12

Safety Instructions



WARNING: To reduce the risk of fire or electrical shock, do not expose this equipment to rain or moisture. Do not remove cover. No user serviceable parts inside. Refer servicing to qualified personnel.

1. **READ INSTRUCTIONS** - Read all safety and operating instructions before operating this product.
2. **RETAIN INSTRUCTIONS** - Retain these safety and operating instructions for future reference.
3. **HEED WARNINGS** - Follow all warnings on this product and in the operating instructions.
4. **FOLLOW INSTRUCTIONS** - Follow all operating and use instructions.
5. **ATTACHMENTS** - Do not use attachments not recommended by the product manufacturer as they may cause hazards.
6. **WATER AND MOISTURE** - Do not use this product near water - for example, near a bathtub, washbowl, kitchen sink, or laundry tub; in a wet basement; or near a swimming pool; and the like.
7. **ACCESSORIES** - Do not place this product on an unstable cart, stand, tripod, bracket, or table. The product may fall, causing serious injury to a child or adult, and serious damage to the product. Use only with accessories recommended by the manufacturer, or sold with the product. Any mounting of the product should follow the manufacturer's instructions and should use a mounting accessory recommended by the manufacturer.
8. **POWER SOURCE** - This product should be operated only from the type of power source indicated on the marking label. If you are unsure of the type of power supply to your home, consult your product dealer or local power company.
9. **OVERLOADING** - Do not overload wall outlets or extension cords as this can result in a risk of fire or electric shock.
10. **LIQUID ENTRY** - Never spill any liquid of any kind on the product.
11. **SERVICING** - Do not attempt to service this product yourself. Opening or removing covers, may expose you to dangerous voltage or other hazards. Refer all service to qualified service personnel.
12. **DAMAGE REQUIRING SERVICE** - Unplug this product from the wall outlet and refer servicing to qualified personnel under the following conditions:
 - a. When the power-supply cord or plug is damaged.
 - b. If liquid has been spilled, or objects have fallen into this product.
 - c. If the product does not operate normally by following the operating instructions. Adjust only controls that are covered by the operating instructions as an improper adjustment of other controls may result in damage and will often require extensive work by a qualified technician to restore the product to its normal operation.
 - d. If the product has been dropped or damaged in any way.
 - e. When the product exhibits a distinct change in performance - this indicates a need for service.
13. **REPLACEMENT PARTS** - When replacement parts are required, be sure the service technician has used replacement parts specified by the manufacturer or have the same characteristics as the original part. Unauthorized substitutions may result in risk of fire, electric shock, or other hazard.
14. **SAFETY CHECK** - Upon completion of any service or repairs to this product, ask the service technician to perform safety checks to determine that the product is in proper operating condition.
15. **HEAT** - This product should be situated away from heat sources such as radiators, heat registers, stoves, or other products that produce heat.

1. Philosophy & Introduction

Blue Sky is a philosophy. We design each product to represent the highest ratio possible of performance to cost, providing the highest value added to our customers.

We will continually seek out opportunities to utilize the talent of the Blue Sky team to realize this philosophy. Our customer's value requirements will always be our prime focus, and only those products that achieve our performance value ratio will earn the right to carry the Blue Sky logo.

The Blue Sky | BMC continues our lineage and philosophy of high value and superior performance products. Designed for use with 5.1 channel monitoring systems, the Blue Sky | BMC allows for complete control of all monitoring system parameters from a single, easy-to-use, remote control.

The Blue Sky | BMC eliminates the many variables of putting together a reliable, easy to calibrate 5.1 monitoring system, allowing the user to monitor with confidence!

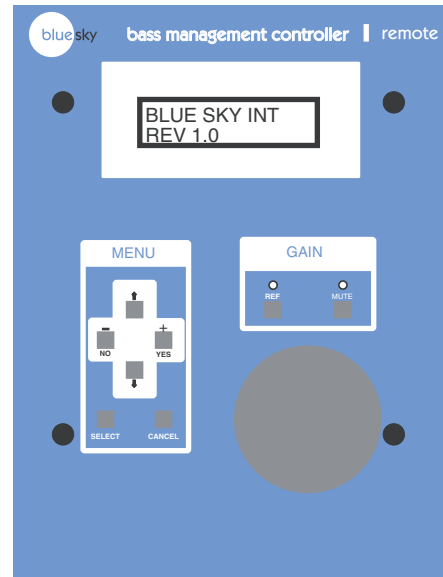

2. A Tour of the BMC - Main I/O

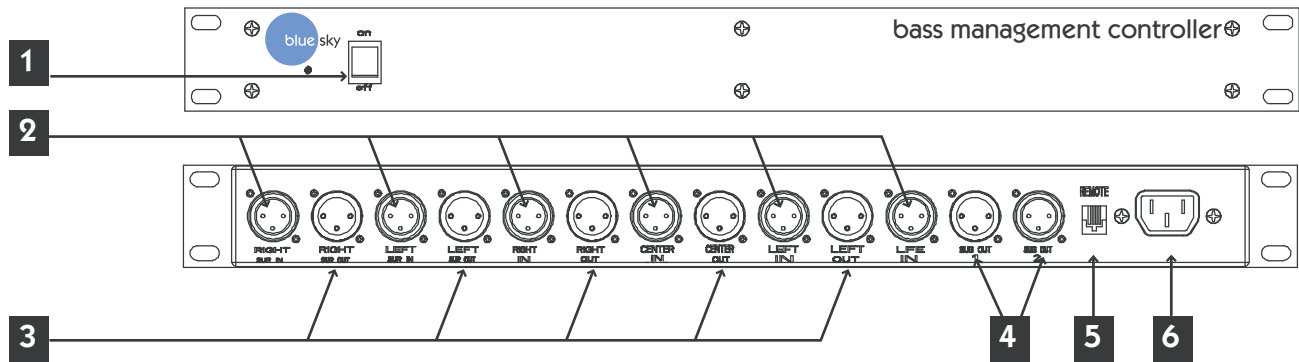

- | | |
|---|--|
| <p>1. Power Switch - This switch controls the power to the BMC Remote and all internal electronics.</p> <p>2. 5.1 Channel Inputs - These XLR inputs should be connected to the 5.1 channel outputs of your console or digital workstation. The inputs are electronically balanced. Do not connect more than one source to these inputs. Refer to the wiring table on page 10 for wiring custom cables and connectors.</p> <p>3. L, C, R, LS & RS Outputs - These XLR outputs should be connected to the inputs of the active satellite speakers. These outputs are electronically balanced. These outputs can be full range or bass-managed with a bandwidth limited to spectral content above 80Hz. Refer to the wiring table on page 10 for wiring custom cables and connectors.</p> | <p>4. Parallel Subwoofer Outputs - These outputs can be used to drive one or more subwoofers. The output signal is the sum total of both the LFE and the bass-managed subwoofer signal (when the bass-management feature is being used). Refer to the wiring table on page 10 for wiring custom cables and connectors.</p> <p>5. Remote Control RJ-11 Connector - This standard six conductor RJ-11 jack is used to connect the main I/O unit to the BMC Remote. The remote control cable length should not exceed 100 Feet.</p> <p>6. IEC Power Terminal - Input Power Voltage 120 VAC / 60Hz or 240 VAC 50 / 60HZ (set at the factory), rated for 15-Watts. Use the included IEC Power Cable.</p> |
|---|--|

3. A Tour of the BMC | Remote

1. RJ-11 Main BMC Control Output - Connect this plug to the Main BMC I/O unit with the supplied 25 ft 6 conductor phone cable. This cable can be extended to a maximum of 100ft using standard 6 conductor phone (not data) cable.
2. RJ-11 Aux BMC Control Output - Reserved for future expansion.
3. + / YES Button - Used to adjust parameters within the submenus. Press to increase individual channel levels, mute channels and set the reference gain setting. See the Software Overview section on page 6 for more information.
4. Arrow Up - Navigation Button - Used to scroll up through the software submenus. See the Software Overview section on page 6 for more information.
5. - / NO Button - Used to adjust parameters within the software. Press to decrease individual channel levels and un-mute channels. See the Software Overview section on page 6 for more information.
6. Arrow Down - Navigation Button - Used to scroll down through the software submenus. See the Software Overview section on page 6 for more information.
7. REF (reference) LED - "ON" when the system gain is set to the user predefined reference level setting. See item 10 below.
8. MUTE LED - "On" when all outputs have been muted. "Flashing" when one or more channels have been muted within the "Mute Channels" submenu of the software. See item 9 below.
9. MUTE Control Button - Toggles the system in and out of mute. Press this button to mute all outputs. Press again to cancel Mute. Moving the Volume Control Knob will also cancel mute. See the Software Overview section on page 6 for more information
10. REF (reference) Control Button - Toggles the system in and out of reference gain. Press this button to set the gain to the user defined reference gain. Press again to cancel. Moving the Volume Control Knob will bring the system out of the reference setting. See the Software Overview section on page 6 and the 5.1 System Calibration Section on page 9 for more information
11. SELECT Button - Press to activate menu and press again to scroll through the main software menus, "Mute Channels", "Calibrate CH(annels)" and "Setup Menu". See the Software Overview section on page 6 and the 5.1 System Calibration Section on page 9 for more information.

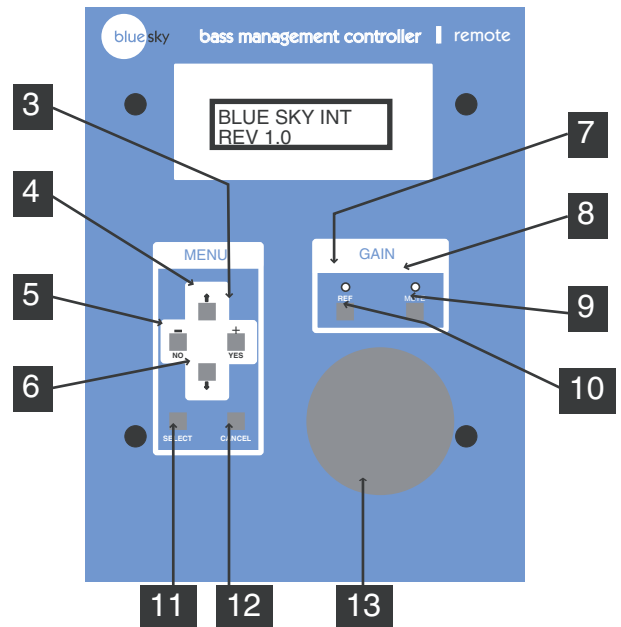
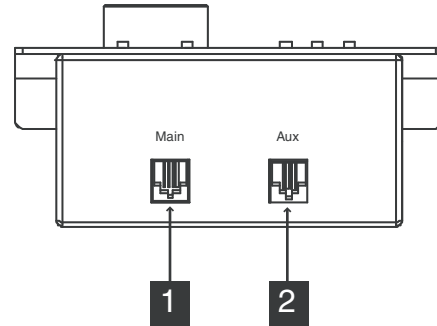

12. CANCEL Button - Press to cycle backwards through the menu and to cancel menu operation. See the Software Overview section on page 6 for more information.
13. VOLUME Control Knob - Turn to control to set overall nominal system gain from -50 dB to 0 dB, in .5dB increments. Turning this knob will cancel MUTE and REF gain operation. Turning this knob while in the menus will temporarily override menu operation to adjust the system gain. Once knob is released, the menu will be reactivated.

4. System & Software Overview

System Gain

The BMC is a studio quality bass management controller with an integral multi-channel volume control. The input stage is designed for a maximum input level of +24dBu (balanced or unbalanced) before clipping. The output stage will also drive a balanced 10K Ohm load to a maximum of +24dBu. However, because the BMC can add up to +6dB of gain to a channel to balance the system, there are situations where the BMC will clip. For example you cannot take a +24dBu input, set the system gain at 0dB, add +6dB of calibration gain to the signal and get +30dB on the output. The output amplifiers in the BMC will clip under these conditions.

Although this may seem to be a limitation, in practice it is not. The Blue Sky monitors, like most amplified monitors, have relatively high voltage sensitivity. Therefore, there is quite a bit of flexibility in setting gains.

For the best signal to noise ratio and to minimize noise and hum pickup, the BMC should be driven with as high a signal level as possible. The output signal going to the speakers should be kept relatively high and if necessary signals should be attenuated at the monitors.

System Power Up Sequence -

1. Although the system will startup without the BMC | Remote being connected, in order to calibrate the system and gain full access to all of the systems features, the BMC | Remote must be connected to the I/O box(es). Once the system has been calibrated, the remote can be disconnected and the main I/O unit will retain all the setup information. Once the systems' power is cycled, the main I/O box will power up fully calibrated and at the "reference" position. See the Software Overview section on this page and the 5.1 System Calibration Section on page 9 for more information.
2. The startup sequence is activated when ever a remote is connected to the I/O box or when the power is cycled with the remote connected. The power up sequence is as follows -
 - A:** The LEDs may flash momentarily as the remote receives power from the main I/O unit. The power LED on the front of the I/O box(es) should be lit.
 - B:** Within the I/O box(es) the output relays will click on.
 - C:** The LCD will display the current software version for 5 seconds. "Blue Sky Ver REV 1.0"
 - D:** After the system has been fully activated the system will go into the mute mode and the display will show the following message. "SYSTEM MUTED".

BMC Power Up Sequence

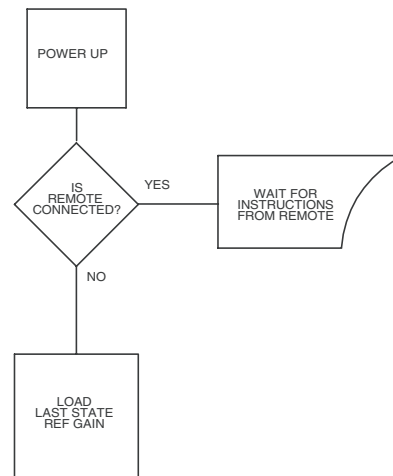

BMC Software Overview

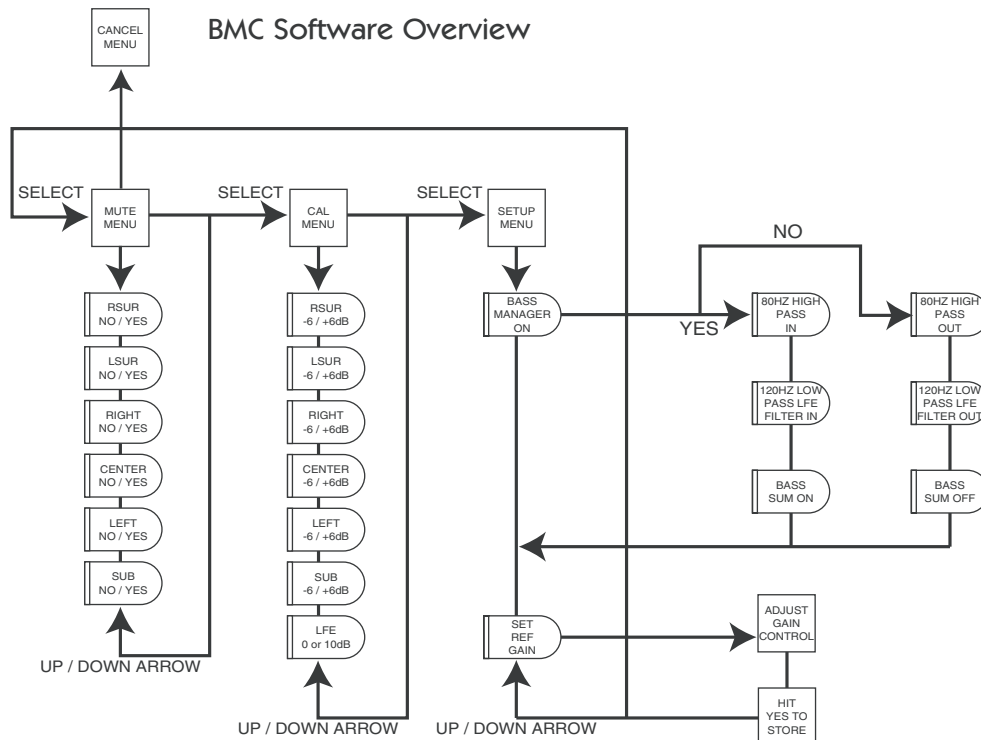

5. 5.1 Speaker Placement

Satellite Speaker Placement - MUSIC

The recommended monitoring angle for proper stereo imaging with music is 60 degrees between **the left and right speakers**. The **center channel** speaker should be located on axis with the reference monitoring position and both the **left and right surround channel speakers** should be at an angle of 110 degrees from the centerline. In most applications, surrounds used for music are placed at the same height as the front speakers for a direct sound field. See Figure 1

Satellite Speaker Placement - FILM / POST PRODUCTION

Although the above recommendations should work equally well for both film and music production, there may be situations where a more "film" optimized setup is desirable. To correctly relate audio to picture, the recommended angle between **left and right speakers** is 45 degrees. This narrower monitoring angle should still yield a very satisfactory stereo image. As with the "music" setup, the **center channel** speaker, should still be located on axis with the reference monitoring position. Unlike music surrounds, which tend to be direct in nature, film surrounds are usually positioned for a more diffused sound field to simulate the effect of an array of surround speakers used in a theater. For a single pair of surrounds, this can be accomplished by placing them two feet above seated ear height, to the side of the monitoring position and slightly by behind the mix position. For larger rooms, it may also be desirable to use multiple surround speakers as an "array".

Satellite Speaker Monitoring Height Recommendations

It is recommended that all of the satellite speakers be placed at or about seated ear height, as shown in Figure 2. If it is not possible to place the speakers at or about seated ear height, please aim the speakers at the monitoring position.

Subwoofer Speaker Placement

Although you have great flexibility in positioning a subwoofer, a good starting point is centered between the left and right satellite speakers. This could be under the console, behind the console, etc. Placing the subwoofer closer to a corner or wall will increase acoustic efficiency and may yield better acoustic response in many situations. However, because of the many variables that relate to "in-room" subwoofer performance, we highly recommend experimenting with subwoofer placement.

Speaker placement recommendations, with regard to these types of installations, vary greatly on the end users' goals and surround philosophy. For more specific information regarding your particular installation, please do not hesitate to contact Blue Sky directly. www.abluesky.com

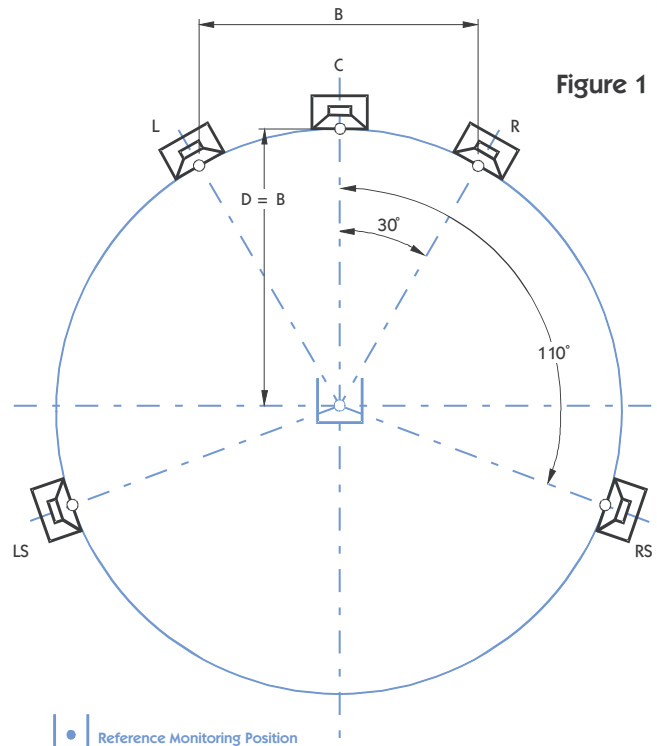
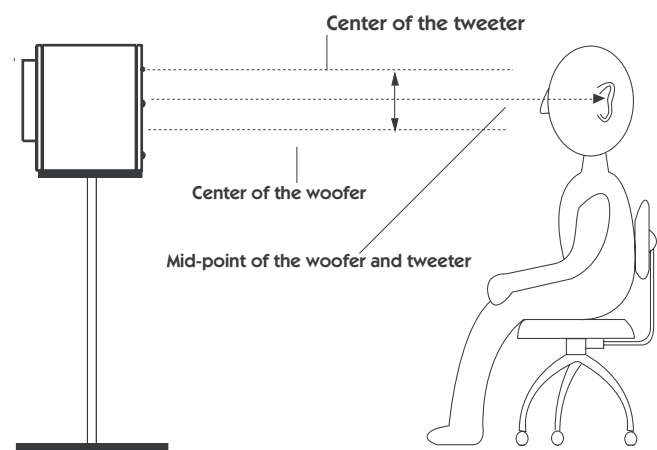

Figure 1

SPEAKER PLACEMENT AS DOCUMENTED IN RECOMMENDATION ITU-R BS.775-1

Figure 2



MONITORING HEIGHT RECOMMENDATIONS

6. System Wiring Diagram

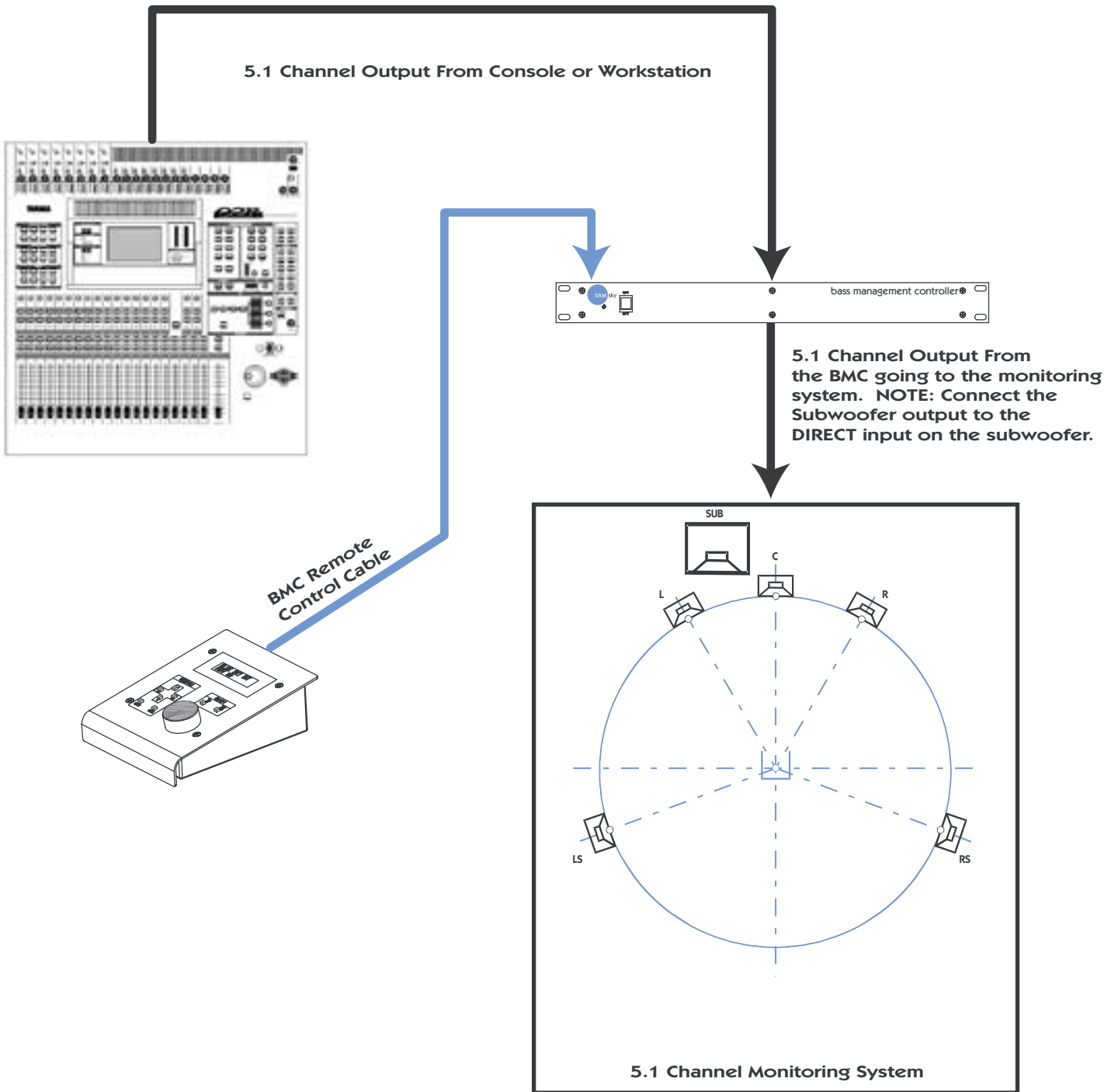

7. 5.1 System Calibration

The following system calibration instructions are for a bass-managed speaker system, such as Blue Sky's ProDesk or Sky System One.

Step 1 "BASS MANAGER - ON" - Press **SELECT** three times, or until the display reads "SETUP MENU". Press the **UP** or **DOWN ARROW** keys until the display reads "BASS MANAGER - ON". If the display reads "BASS MANAGER - OFF", press **YES** To turn it on. Now press **CANCEL** until you have backed out of all the menus.

STEP 2 "MUTE THE SUBWOOFER" - Press the **SELECT** once, or until the display reads "MUTE CHANNELS". Press the **UP** or **DOWN ARROW** until you get to the subwoofer channel and then press **YES**. The MUTE LED will flash. Now press **CANCEL** until you have backed out of all the menus.

STEP 3 "FINDING YOUR REFERENCE LEVEL" - Turn the gain on the remote to -50dB. Patch a pink noise generator, tape or other source with at least 60 seconds of 0dBVU Pink Noise into your console or workstation. If you are using a digital source, the test signal should measure -20dB FS (0dB FS = Full Scale Digital). Assign the test signal to the center channel only. Confirm that all your speakers are turned on and that the gain on each speaker is set to a moderate level. Slowly bring up the gain with the master **Volume Control** knob on the BMC | Remote until you measure 85dB on the C scale, with the response set to Slow. Measure SPL exactly at the reference mix position, with the SPL meter at arms length, the microphone at seated ear height, angled at approximately 45 degrees, and pointed at the center speaker. If you are using a 1/3 octave RTA, align the level of the speakers to 70dB reference line on the analyzer. Note the gain displayed on the remote when the center channel is at 85dBc. If it is less than -20dB turn the gain on the back of the center channel monitor down and increase the level of the BMC until a good compromise is reached. Typically using a reference gain setting of -10dB is a good choice between overall electrical headroom, input signal level, output signal level and giving you an additional 10dB of system gain when necessary.

Once the "Reference Level" setting has been determined, turn off the pink noise, make a note of the System gain reading on the remote. Set the gain controls of the rest of the monitors to the same level as the center channel. Now follow STEP 4 to enter the "Reference Level" into memory.

STEP 4 "SETTING THE REFERENCE LEVEL" - Press **SELECT** three times, or until the display reads "SETUP MENU". Press **UP** or **DOWN ARROW** until **"SET REF GAIN"** is on the display. Turn the **Volume Control Knob** until the SYSTEM GAIN equals the gain noted above in STEP 3. Release the knob and press **YES** when the menu reappears. You have now successfully stored the preset reference level. Press **CANCEL** three times to exit the menu.

STEP 5 "FINAL SATELLITE SPEAKER CALIBRATION" (subwoofer should still be muted) It is extremely important that you set the volume control to the reference level prior to starting the calibration of the system. Do not adjust the knob during the calibration function.

Press **SELECT** twice until the display reads "CALIBRATE CH". Press the **DOWN ARROW** key until it reads RSUR (right surround). Turn on the calibrated pink noise source (making sure to assign it to the channel that is being calibrated) and trim the gain using the **+** or **-** keys until the SPL meter reads 85dBc (for the surrounds it may be necessary to point the SPL meter towards the back of the room to get a more accurate SPL measurement). If you are using a 1/3 octave RTA, align the level of the speakers to the 70dB reference line on the analyzer. Once each channel is set, use the **DOWN ARROW** key to scroll through the other channels and then use the **+** or **-** buttons to adjust the level as described above. Stop when you get to the SUB (subwoofer) and press **CANCEL** to exit this part of the calibration.

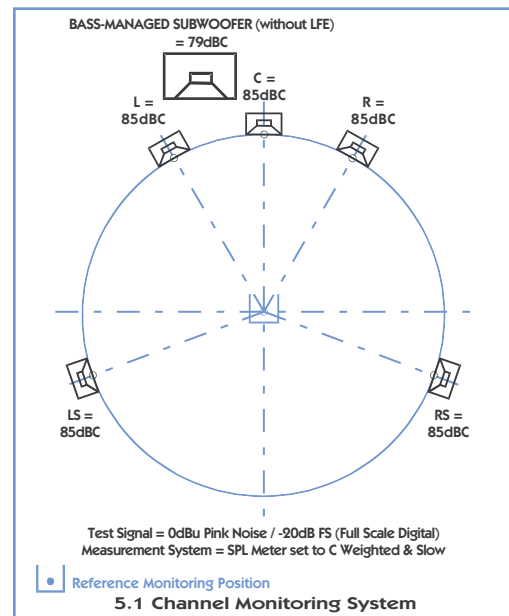
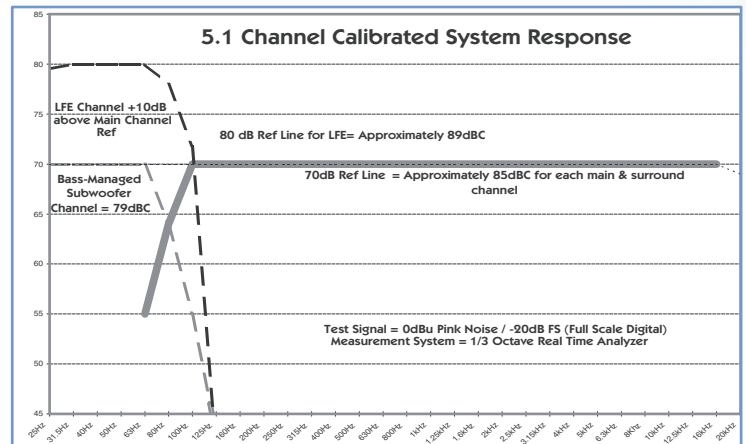

STEP 6 "SUBWOOFER CALIBRATION" Press **SELECT** once, or until the display reads "MUTE CHANNELS". Mute the Left, Center, Right, Left Surround and Right Surround Channel by selecting, with the **DOWN ARROW** key, and pressing **YES**. Un-mute the Subwoofer Channel (by pressing the **NO** button). The Mute LED will flash.

Confirm that the volume control is set at the "Reference Level" as described in STEP 3. Press **SELECT** Two times, or until the display reads "CALIBRATE CH". Press the **DOWN ARROW** key to scroll through each channel until you get to the SUB (subwoofer). Feed the pink noise to the CENTER channel only. No noise should be coming from any of the satellite speakers (they are muted). Now, using your SPL meter, adjust the level of the subwoofer until it reads 79dBc (allow enough time for the display to settle and make a mental average), you may also need to physically adjust the gain on the subwoofer. If you are using a 1/3 octave RTA, align the level of the subwoofer to the 70dB reference line on the analyzer. Next, turn off the pink noise signal, press the **DOWN ARROW** button, and press **YES** to set the LFE to +10dB (as recommended by Dolby). Press **CANCEL** to go back to the MUTE MENU and un-mute each channel (the mute LED should be off when this step is completed). **The calibration process is now complete! Please make a note of all the settings.** (Additional Setup information is available on page 10.)

8. Additional Setup Information

Using the Blue Sky | BMC as a multi-channel volume control

There may be applications where the Blue Sky | BMC may only be used as a multi-channel volume control. The bass-manager OFF function can be accessed within the SETUP MENU. Once at this menu, press the down arrow button until the display reads Bass-Manager. Press the NO button to defeat the bass-management function. Once this is done, the unit will operate purely as a six channel volume control (press cancel to escape out of this menu). The LFE 120Hz low pass-filter will now also be defeated (making the LFE input/output full-range). However, the LFE +10 / 0dB boost can still be selected. To defeat this, enter the Calibrate CH. menu, scroll down using the arrow down buttons, and toggle the setting using the + / - buttons. Once the desired setting has been entered, press cancel to exit this menu.

The LFE Channel

The LFE Channel was originally designed for film applications as a way to extend the low frequency "head-room" (not frequency response) of the playback system. This additional headroom was created by adding +10dB of in-band gain to the LFE channel. This channel should only be used when no additional headroom is available in the other channels for low frequency effects. As an example, you may use the LFE channel to increase the dynamic low frequency content of a movie that has many large explosions. This is rarely the case in music, although there may be some creative reasons to use the LFE from time to time. It is important to note that no "significant" audio should be sent exclusively to the LFE channel. The reason for this is that if a Dolby Digital audio track is folded down to 2-channels, which can happen if a consumer doesn't have a surround system, the LFE channel will not be added to the fold-down mix (all other channels will be added to the fold-down).

Future Expansion

The Blue Sky | BMC is a digitally controlled analog product. It was designed to be software upgradeable. Please check the Blue Sky website for future upgrades. www.abluesky.com

Need to know more about multi-channel audio?

There is a wide variety of technical information available on the internet regarding multi-channel audio. If you need more specific information regarding multi-channel audio and Blue Sky International, please do not hesitate to contact us directly.

www.abluesky.com

Additional Technical Resources -

Source: The Audio Engineering Society
Website: www.aes.org

Source: Digital Theater Systems, Inc.
Website: www.dtsonline.com

Source: Dolby Laboratories
Website: www.dolby.com

Source: Society of Motion Picture and Television Engineers
Website: www.smpte.org

Source: Surround Associates
Website: www.surroundassociates.com

Source: The THX Division of Lucasfilm Ltd.
Website: www.thx.com

9. Cable and Wiring Information

Use high-quality, shielded cables to connect your console, workstation or other source to your Blue Sky | BMC. Foil-shielded cables, such as Belden 8451, 8761, or 9501 should do quite well. Other high quality cables are available and those that incorporate better shielding will yield an overall higher noise rejection, lowering your systems susceptibility to external interference. Another important tip to keep in mind when wiring your system is to route all line level cables away from the AC and other power sources, this will reduce the probability of having AC hum emanating from your monitoring system..

	XLR	TRS	RCA
HOT (+)	Pin 2	Tip	Tip
COLD (-)	Pin 3	Ring	
SHIELD (Ground)	Pin 1	Shield	Shield

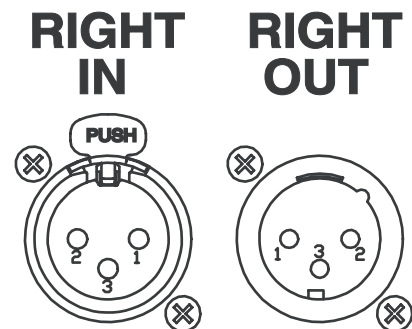

10. Technical Information

Input Impedance	20k Ohms balanced
Common Mode Rejection Ratio	40dB typical @60Hz
Maximum Input Level (all inputs)	+24dBu balanced
Maximum Output Level	+24dBu balanced
Output Impedance	200 Ohms balanced
Nominal max gain	0 dB
Gain trim range	+/- 6dB
Signal to noise ratio	> 105dB
Output noise	-85dBu (20 to 20kHz)
THD + Noise (0dB of gain)	.002% @ 1kHz @ +10dBu
Frequency Response	20 Hz to 20KHz +/- .25dB (Volume Control Mode)
High-Pass Filter type	2nd order Linkwitz-Riley
High-Pass Filter Cutoff	80Hz
Low-Pass Filter Type	4th order Linkwitz-
	Riley
Low-Pass Cutoff	80Hz
LFE Input	
Gain	0dB / +10dB Selectable
Low-Pass Filter	120Hz
Input power	120 VAC 60HZ 240 VAC 50/60HZ 15-Watts (Voltage set at the factory)

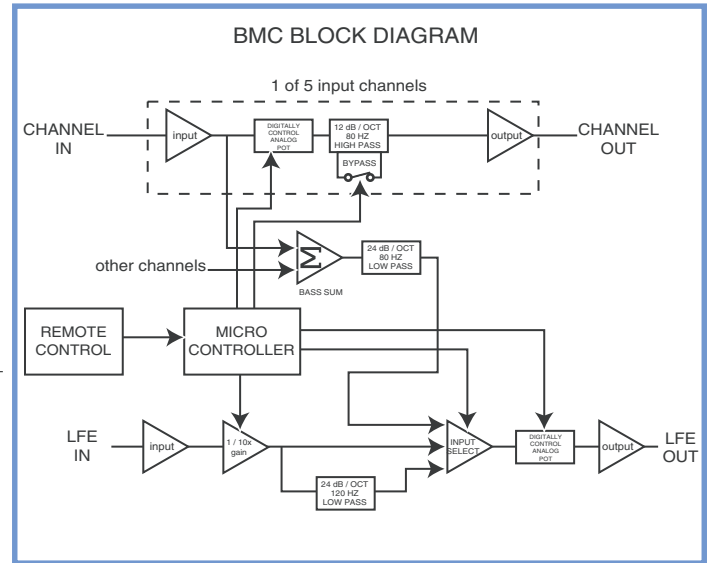

11. Product Dimensions

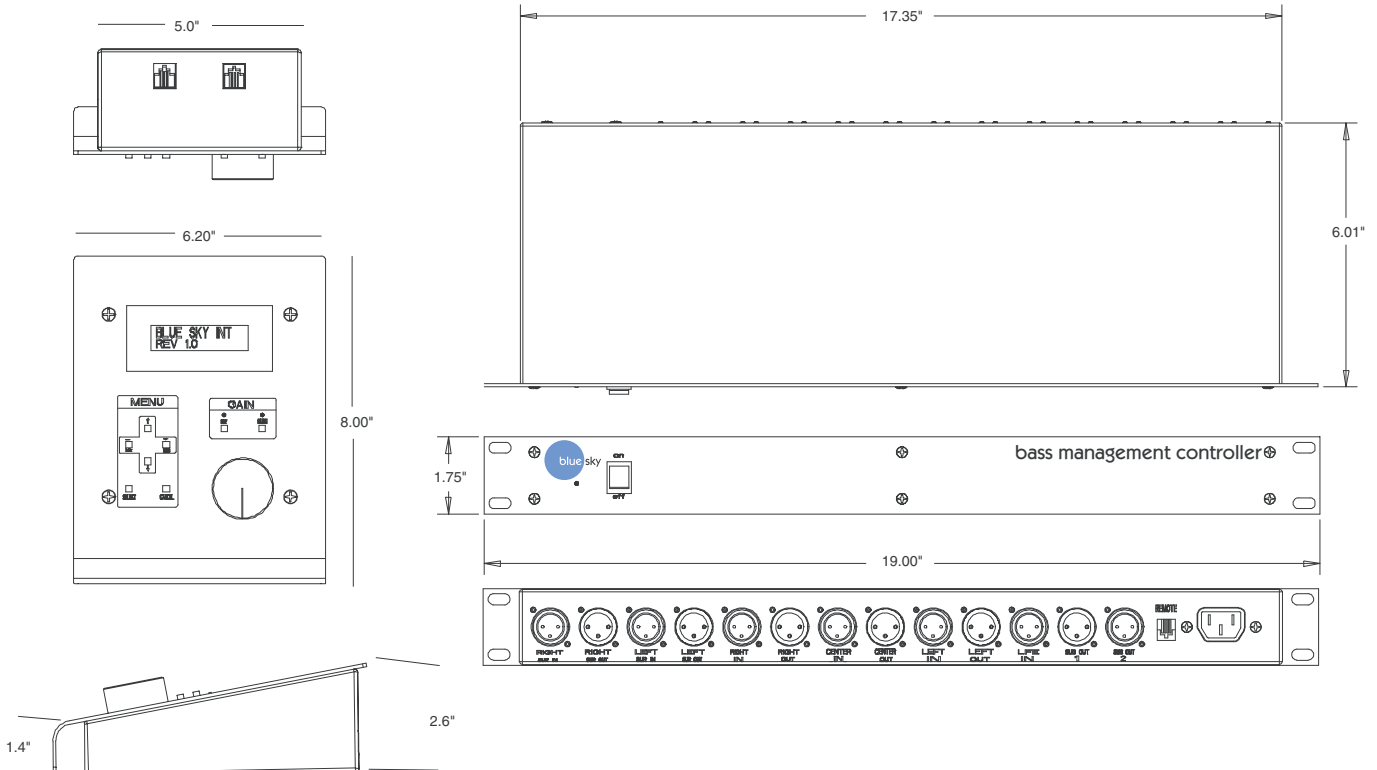

12. Factory Service Instructions

Service for the U.S. versions of Blue Sky products is available only from our authorized distributor, Group One Ltd., located in Farmingdale, New York. (Service for Blue Sky products outside the United States can be obtained through local dealers or distributors.)

Blue Sky International
ATTN: SERVICE DEPT / RA#
70 Sea Lane
Farmingdale, NY 11735
USA

If your Blue Sky | BMC needs service, follow these instructions:

1. Review the manual and ensure that you have followed all setup and operating instructions.
2. Call (631) 249-1399 9:00am to 5:30pm EST and ask for Customer Service. Explain the problem and request an RA (Return Authorization) number. It is important to have your product serial number available when you call. You must have an RA number before you can obtain service.
3. Pack the product in its original packing material and box (do not return the power cord or the manual). If you don't have the original packing material and/or box, please let Customer Service know when you call for the RA number. Blue Sky is not responsible for any damage that occurs due to non-factory packaging.
4. Include a legible note stating your name, shipping address (no P.O. boxes), daytime phone number, RA number, and a detailed description of the problem, including how it can be duplicated.
5. Write the RA number on the top of the carton.
6. Ship the product to the address below. We recommend United Parcel Service (UPS). Please insure the product regardless of shipping method.
7. Turnaround time is three to five business days depending on the problem. When calling for RA numbers, please ask Customer Service what the turnaround time is. The serviced product will be sent back to you via the same shipping method as received (i.e. if you ship your monitor UPS Ground it will be returned UPS Ground, UPS Red will be returned UPS Red etc...). This only applies to products serviced under the warranty.

13. Contact Details

For sales and other enquiries, please contact Blue Sky at:

Blue Sky International
70 Sea Lane
Farmingdale, NY 11735
USA

tel: 516 249 3662
fax: 516 249 8870
email info@abluesky.com

To discover the very latest information check out our website at:

www.abluesky.com

