

TRONICALTUNE PLUS

Template Types

There are different templates available for this Headstock – check which one fits your guitar following the guide below:



Tronical

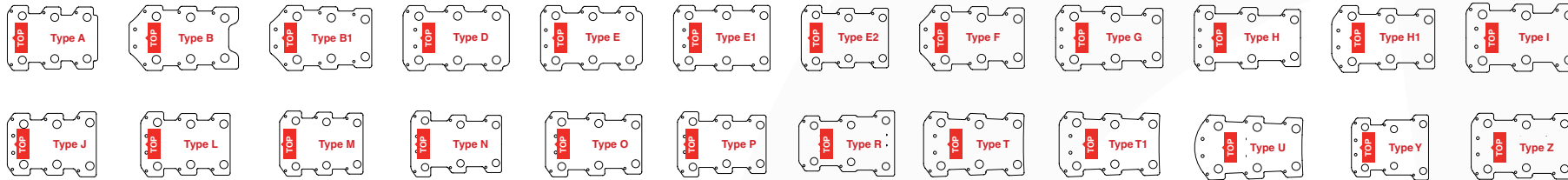

1. Printer Settings:

- Size Setting: 100%
- Page Adaption: None
- Page Scaling: None



2. Place a ruler onto the printed templates to **check correct printout size**

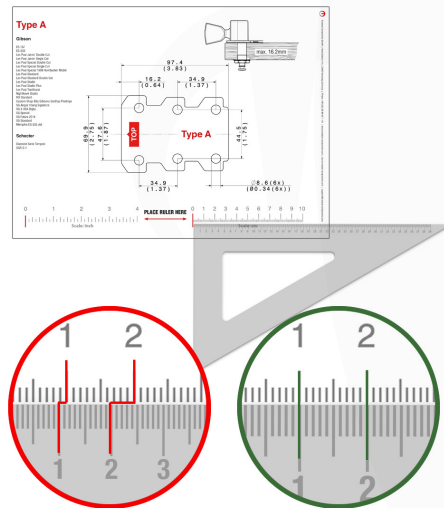

3. Cut-out the templates

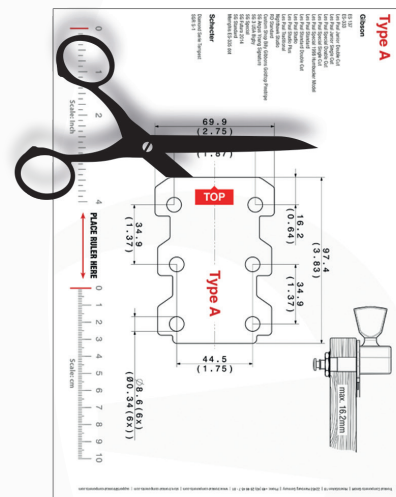

4. Place the templates **on the back** of your guitar headstock. Check if the holes of the template are congruent to the holes of your guitar. When they are congruent you identified the template that fits your guitar. Enter this type during the order process.

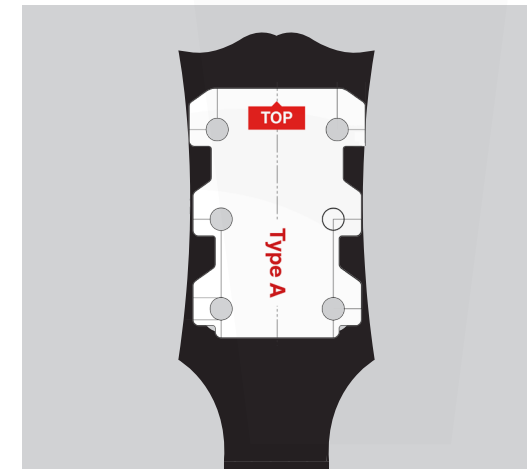

Type A

Gibson

- ES 137
- ES-333
- Les Paul Junior Double Cut
- Les Paul Junior Single Cut
- Les Paul Special Double Cut
- Les Paul Special Single Cut
- Les Paul Special 1998 Humbucker Model
- Les Paul Standard
- Les Paul Standard Double Cut
- Les Paul Studio
- Les Paul Studio Plus
- Les Paul Traditional
- Nighthawk Studio
- RD Standard
- Custom Shop Billy Gibbons Goldtop Pinstripe
- SG Angus Young Signature
- SG 3 USA Bigby
- SG Special
- SG Futura 2014
- SG Standard
- Memphis ES-335 dot

Schecter

- Diamond Serie Tempest
- SGR S-1

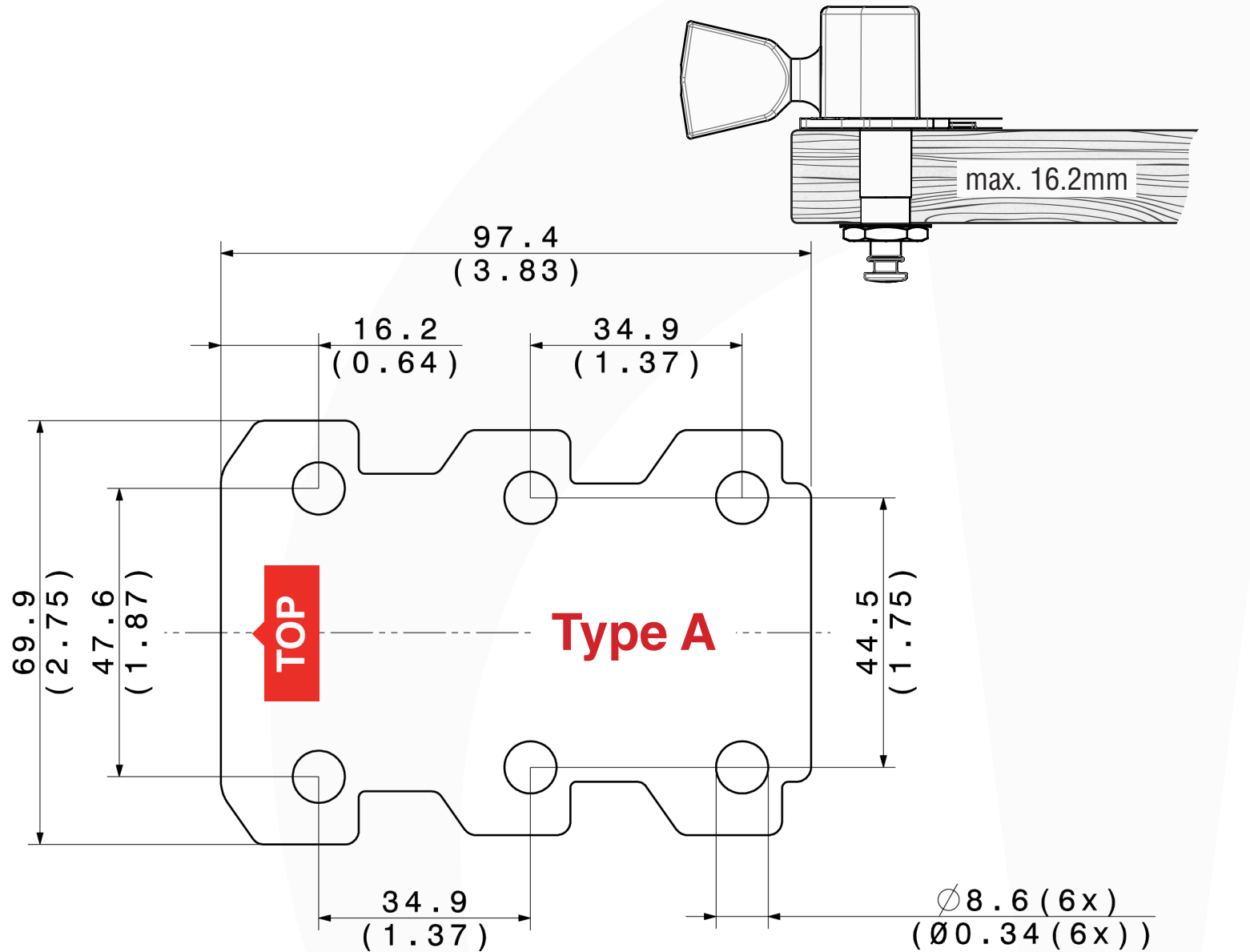

Type B

Gibson

Hummingbird 50th Anniversary 1960
 Jumbo Southern Aaron Lewis
 Jumbo Advanced
 Jumbo Advanced Pro
 Arlo Guthrie LG 2 3/4
 B-25
 Blues King
 Dwight Yoakam Honky Tonk Deuce
 Elvis Costello Limited
 Hummingbird
 Hummingbird New Vintage
 Hummingbird True Vintage
 Hummingbird Custom KOA
 Hummingbird Pro
 J-45 Custom
 J-45 New Vintage
 J-165
 j-165 EC Rosewood
 J-185
 J-185 New Vintage
 J-200 M Trophy '75th Anniversary
 J-45 (except for '42 Legend)
 J-45 ADJ
 J-45 Custom Mystic Rosewood
 J-45 True Vintage
 J-50
 ES 390 Custom Shop
 Jackson Browne Signature
 J-45 John Hiatt
 Keb' Mo' Bluesmaster
 L 00 Pro (except for '37 legend)
 L-200 Emmilou Harris
 Jumbo Advanced Randy Scruggs
 Robert Johnson L-1
 Sheryl Crow
 Sheryl Crow SJ Special Edition
 Songwriter Deluxe
 Songwriter Standard

Jumbo Southern
 Jumbo Southern New Vintage
 Sparrow
 Jumbo Southern The Kristofferson
 Bluegrass Special
 Songwriter Travelling EC
 Jumbo Southern Woody Guthrie

Epiphone

AJ-200 S/N

FGN

Neo Classic LS Goldtop relic
 Neo Classic LS Black LP Standart

Stanford

Neo Classic LS Goldtop relic
 Neo Classic LS Black LP Standart

Brook

Tavy
 Okement

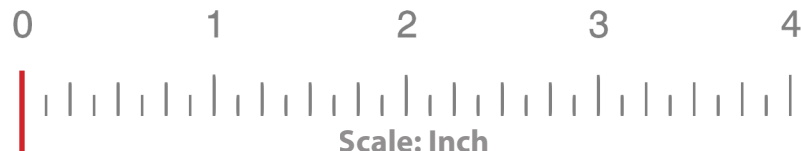
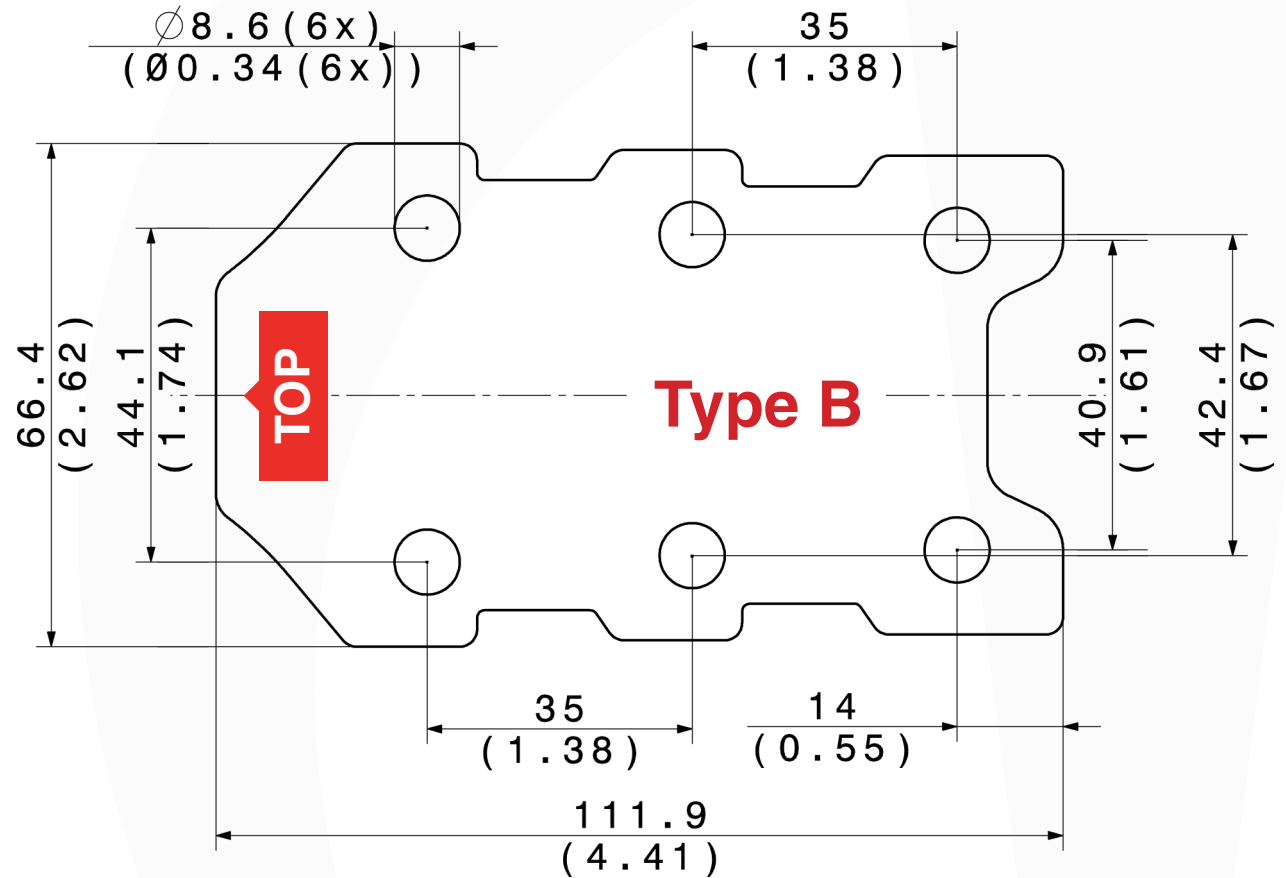
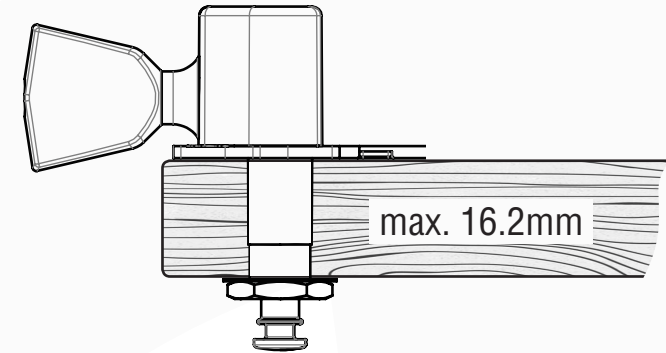

PLACE RULER HERE

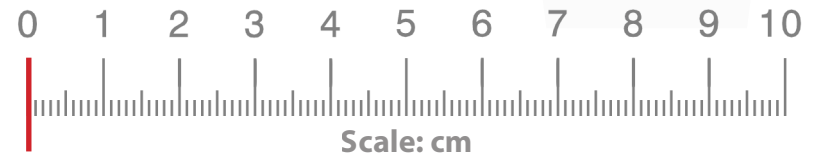

Type B1

Gibson

Les Paul Standard „Joe Walsh“ Collectors Choice
Les Paul 1959 Vintage

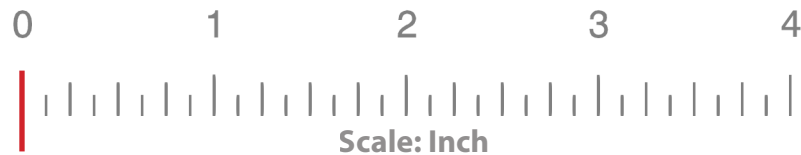
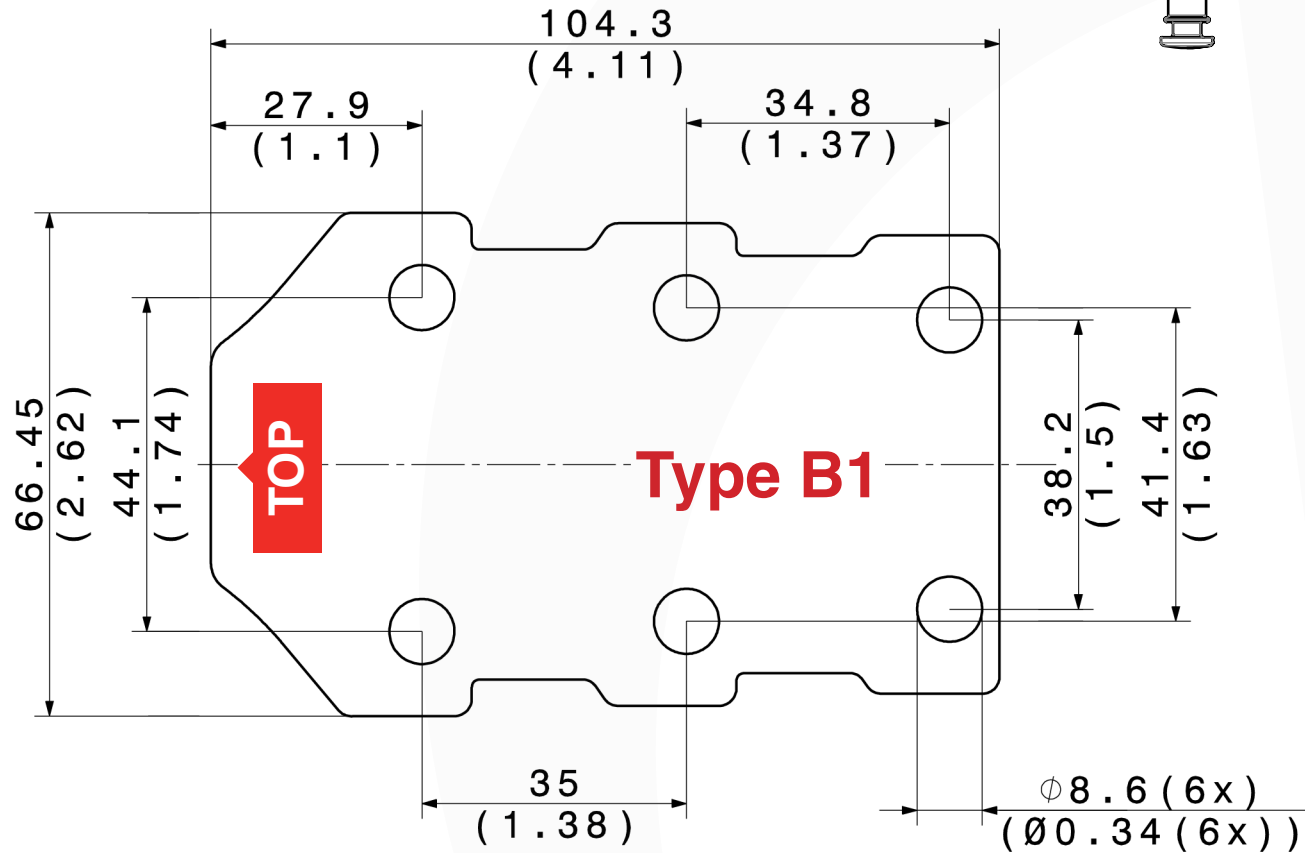
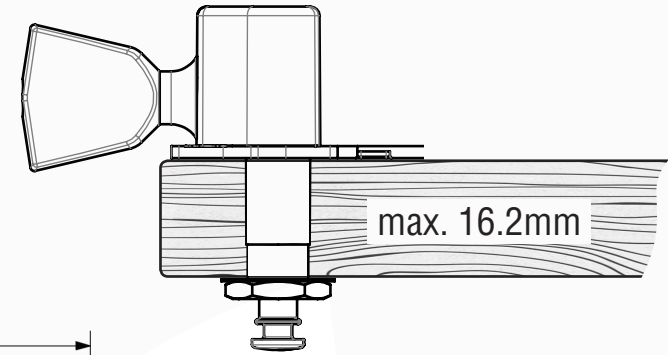

PLACE RULER HERE

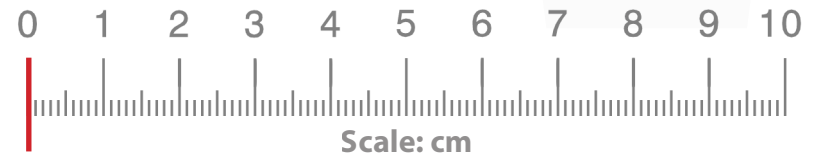

TRONICALTUNE PLUS

Template Types



There are different templates available for this Headstock – check which one fits your guitar following the guide below:

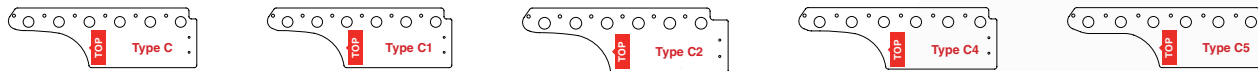

1. Printer Settings:

- Size Setting: 100%
- Page Adaption: None
- Page Scaling: None

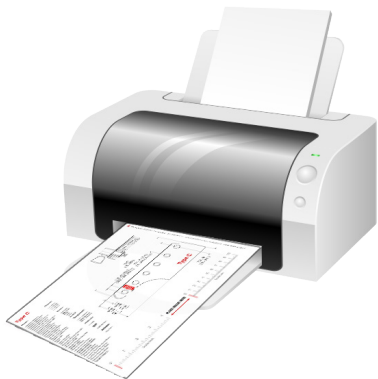

2. Place a ruler onto the printed templates to **check correct printout size**

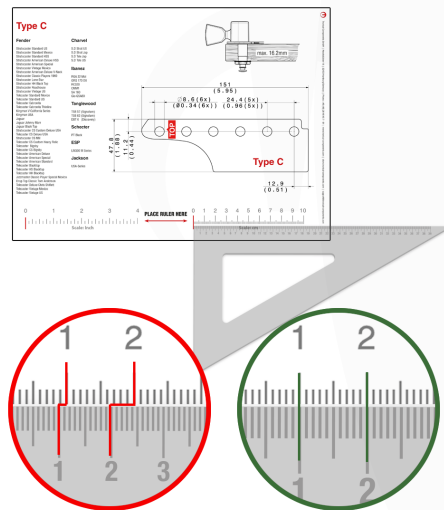

3. Cut-out the templates

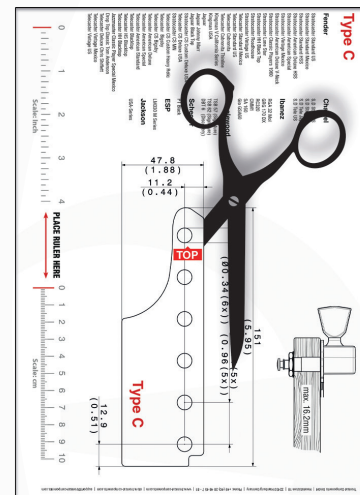

4. Place the templates **on the back** of your guitar headstock. Check if the holes of the template are congruent to the holes of your guitar. When they are congruent you identified the template that fits your guitar. Enter this type during the order process.

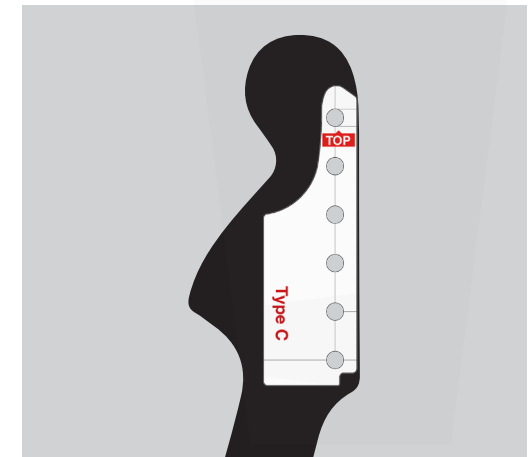

Type C

Fender

- Stratocaster Standard US
- Stratocaster Standard Mexico
- Stratocaster Standard HSS
- Stratocaster American Deluxe HSS
- Stratocaster American Special
- Stratocaster Vintage Mexico
- Stratocaster American Deluxe V-Neck
- Stratocaster Classic Players 1960
- Stratocaster Lone Star
- Stratocaster HH Black Top
- Stratocaster Roadhouse
- Stratocaster Vintage US
- Telecaster Standard Mexico
- Telecaster Standard US
- Telecaster Cabronita
- Telecaster Cabronita Thinline
- Kingman V California Series
- Kingman USA
- Jaguar
- Jaguar Johnny Marr
- Jaguar Black Top
- Stratocaster CS Custom Deluxe USA
- Telecaster CS Deluxe USA
- Stratocaster CS MN
- Telecaster CS Custom Heavy Relic
- Telecaster Bigsby
- Telecaster CS Bigsby
- Telecaster American Deluxe
- Telecaster American Special
- Telecaster American Standard
- Telecaster Blacktop
- Telecaster HS Blacktop
- Telecaster HH Blacktop
- Jazzmaster Classic Player Special Mexico
- Drop Top Classic Tom Anderson
- Telecaster Deluxe Chris Shiflett
- Telecaster Vintage Mexico
- Telecaster Vintage US

Charvel

- S.D Strat US
- S.D Strat Jap
- S.D Tele Jap
- S.D Tele US

Ibanez

- RGA 32 Mol
- GRG 170 DX
- RC320
- CMM1
- SA 160
- Gio GSA60

Tanglewood

- TSB 57 (Signature)
- TSB 62 (Signature)
- DBT 6 (Discovery)

Schecter

- PT Black

ESP

- LM330 M Series

Jackson

- USA-Series

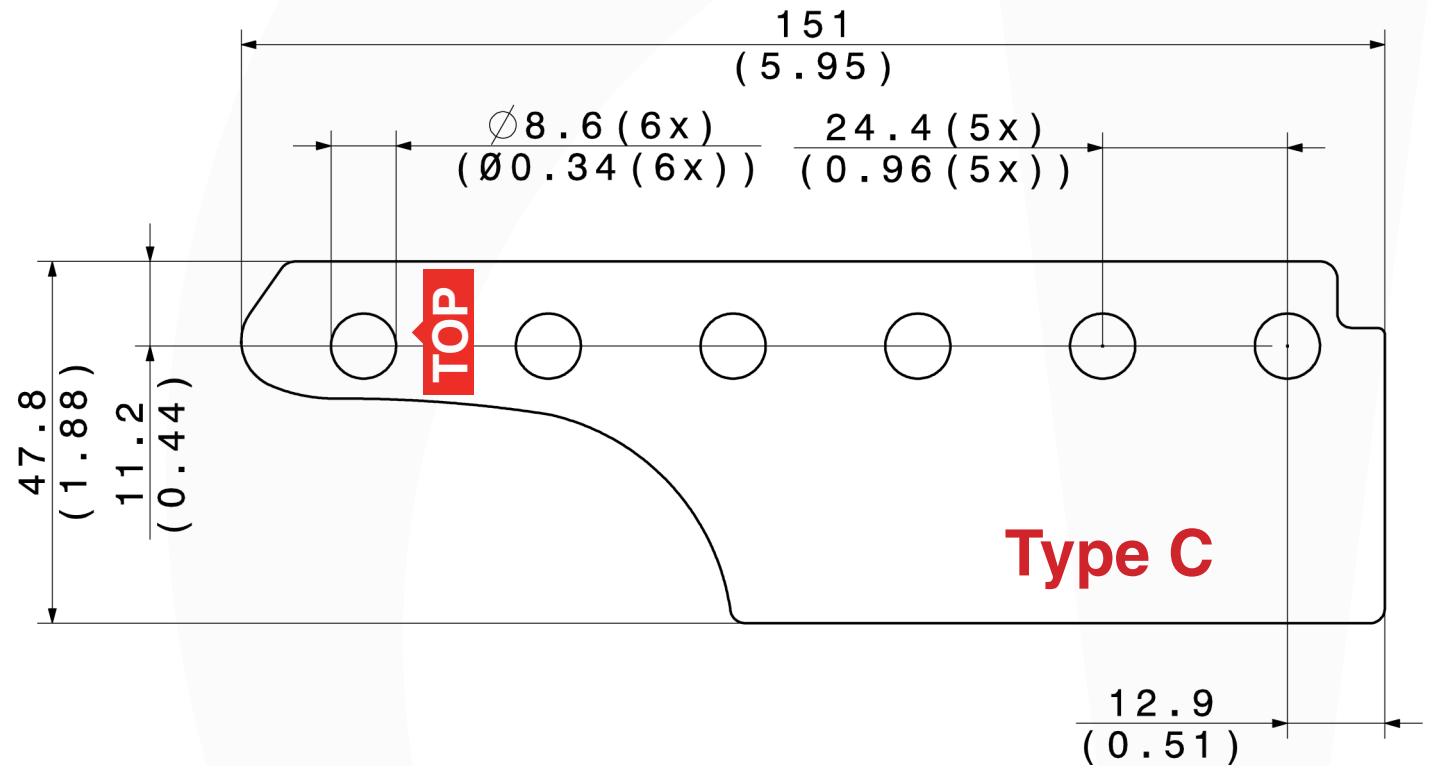
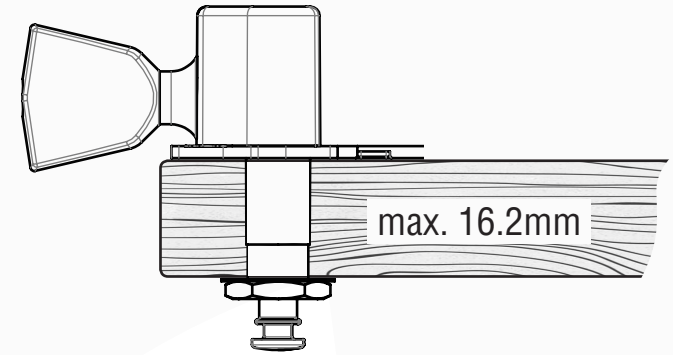

PLACE RULER HERE

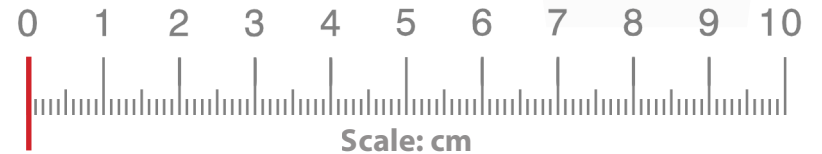

Type C1

Fender

Telecaster CS Thinline 1950
 Telecaster CS Butter Scotch 1952
 Telecaster Relic 1952
 Telecaster Classic Vibe 1960
 Telecaster Classic Vibe Butterscotch Blond 1960
 Telecaster Thinline Classic Vibe 1960
 Telecaster CS Masterbuild 1964
 Telecaster CS Paisley Logo 1970
 Telecaster TY Yellow
 Telecaster Richie Kotzen
 Stratocaster CS Fiesta Red 1950
 Stratocaster NOS Holoflake 1950
 Stratocaster Classic Vibe 1950
 Stratocaster CS Tao Turquoise 1956
 Stratocaster Relic HSS 1957
 Stratocaster NOS 1957
 Stratocaster CS NOS active 1957
 Stratocaster CS Close Classic Masterbuild 1957
 Stratocaster CS Hardtail 1957
 Stratocaster CS Fiesta Red 1960
 Stratocaster Classic Vibe 1960
 Stratocaster CS Doutone Relic 1960
 Stratocaster CS Heavy R 1962
 Stratocaster CS closed classic 1965
 Stratocaster Heavy 1968
 Stratocaster CS Robert Cray
 Mustang
 Telecaster La Cabronita „F“ Hole MN
 Sonoran SCE
 Telecaster Vintage Modified
 Jazzmaster Vintage Modified
 Mustang Vintage Modified
 Jaguar Vintage Modified

Fender Squier

Stratocaster Models Indonesia
 Telecaster Vintage Modified „La Cabronita“ Indonesia
 Stratocaster Classic Vibe China
 Telecaster Classic Vibe China

Lag

Arkane Series 66
 Arkane Series 100
 Arkane Series 200
 Arkane Master 3000
 Master Special Edition

Yamaha

Pacifica (all Modells)

Ibanez

BBM1
 RGIR Serie
 RG370
 RG
 RGR
 RG321
 S 770 PM
 SIR70FD
 S5470 - Serie
 RG440
 S970CW
 JEM Serie
 SA960QM
 RG550XH

Warmoth

Strat style

Vox

Apache 1

James Tyler

JTV 69 Variax

John Suhr

Pro Series

Swing

R Series

Hamer

Slammer Series

Moolon

S Classic

Mike Lull

Electric guitars

Godin

Session - Serie
 Progression - Serie
 Freeway Classic

Schecter

Stratocaster Traditional Series
 Telecaster PT Vintage Series
 California Custom Elite

ESP

E-2 Vinatage Plus
 E-2 Vintage Tele
 LEX50BLK EX

LTD

ST-213
 ST-213 FR
 TE-212

Agostin

Drop Top Custom
 Classic S2
 Classic Korina S3
 Classic Korina S4
 Classic V2
 Art Series Z 24
 Custom Z24
 Classic T
 Classic T Nashville
 Classic T Nashville Tremolo
 Zoe

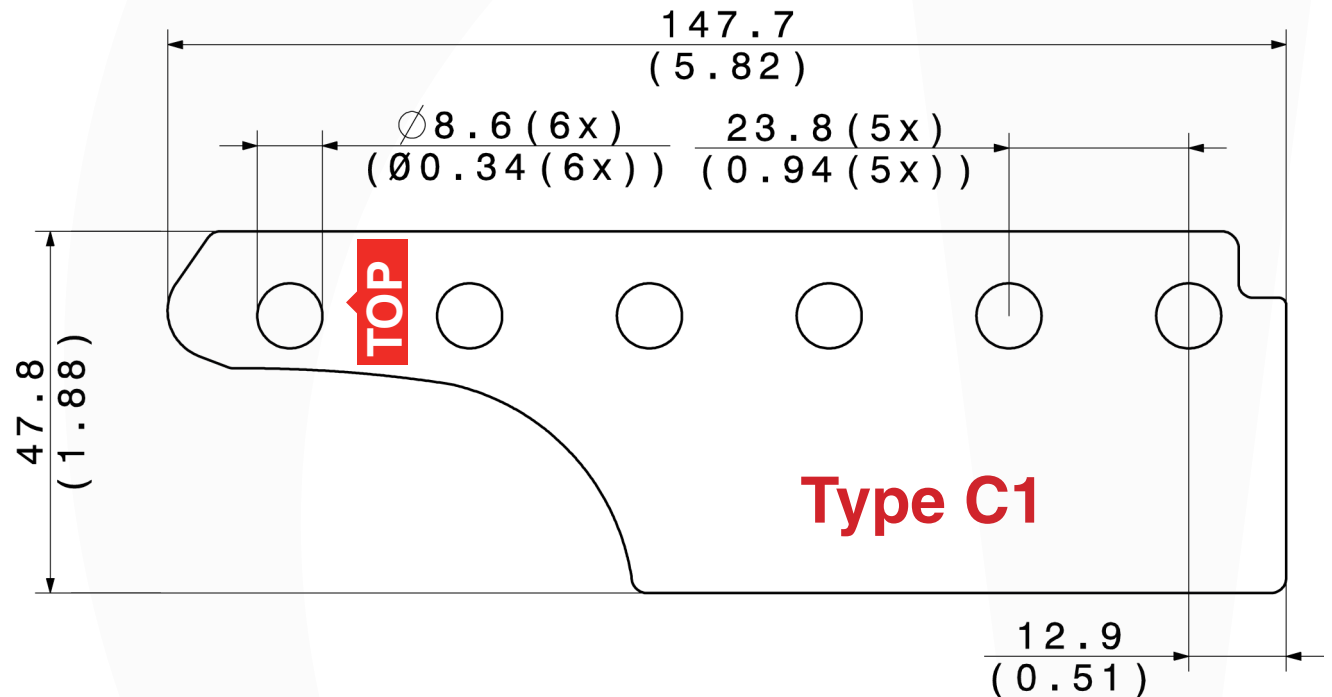
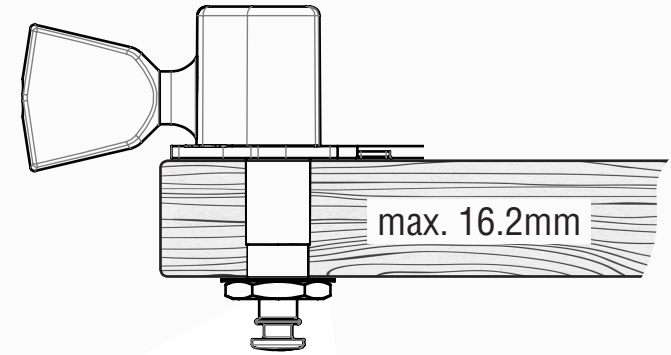

PLACE RULER HERE

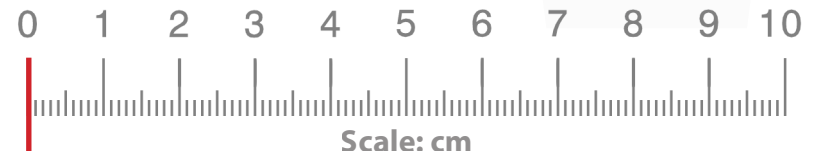

Type C2

Gibson

Explorer 76
Explorer 84
Explorer Bill Kelliher

Epiphone

Explorer Gothic Pitch black
Explorer Pro TV silver ltd.
Explorer 1984 ltd.
Explorer (all Models)

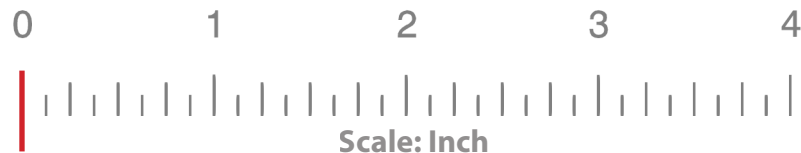
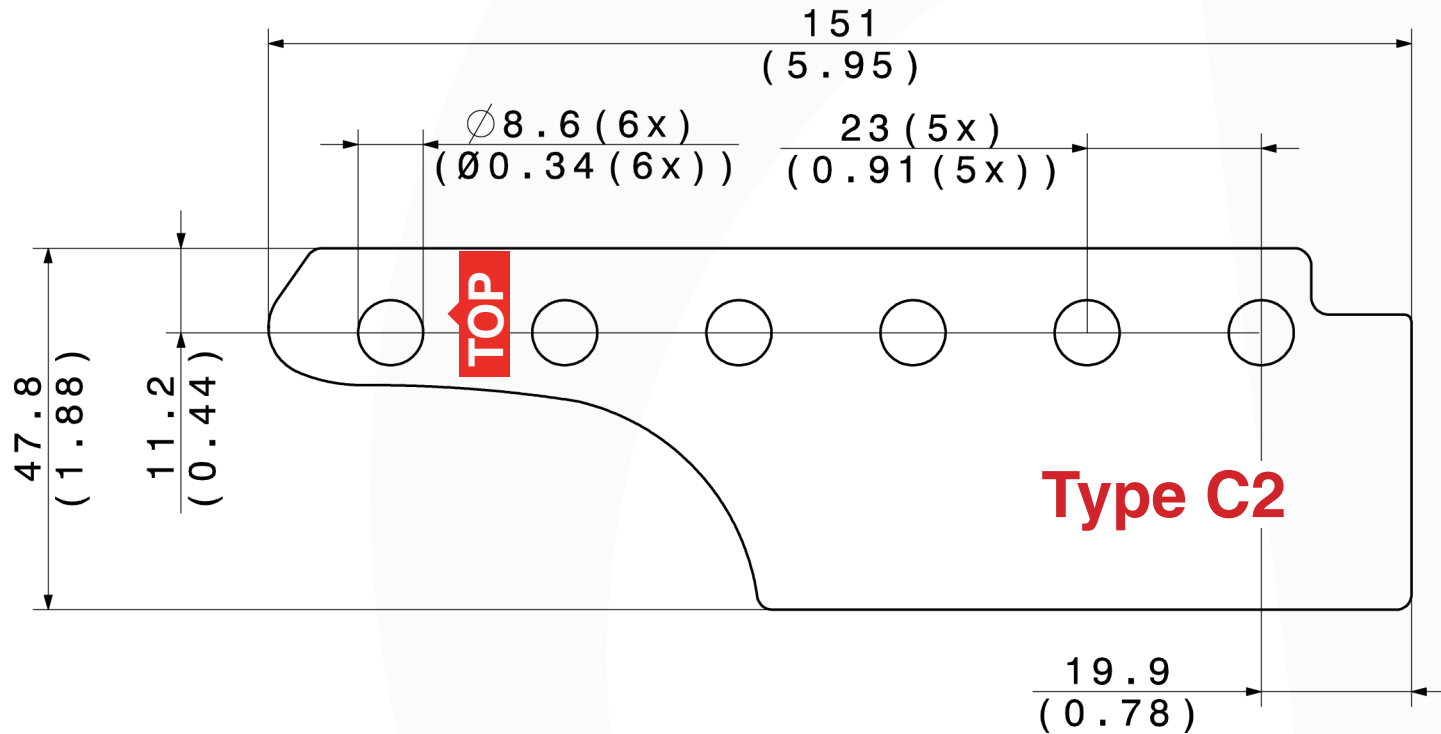
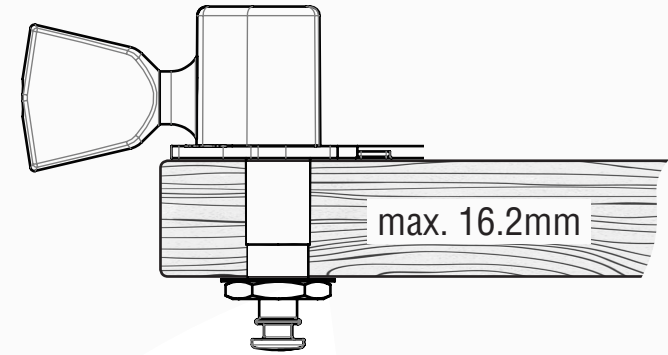

PLACE RULER HERE

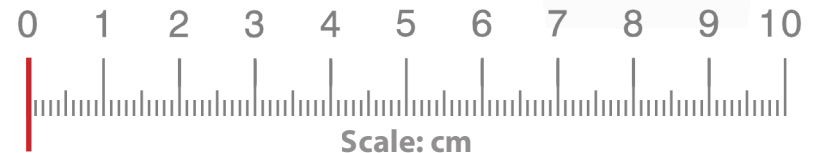

Type C4

Ibanez

Roarcore Series
Destroyer China

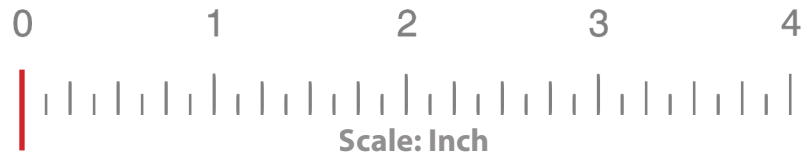
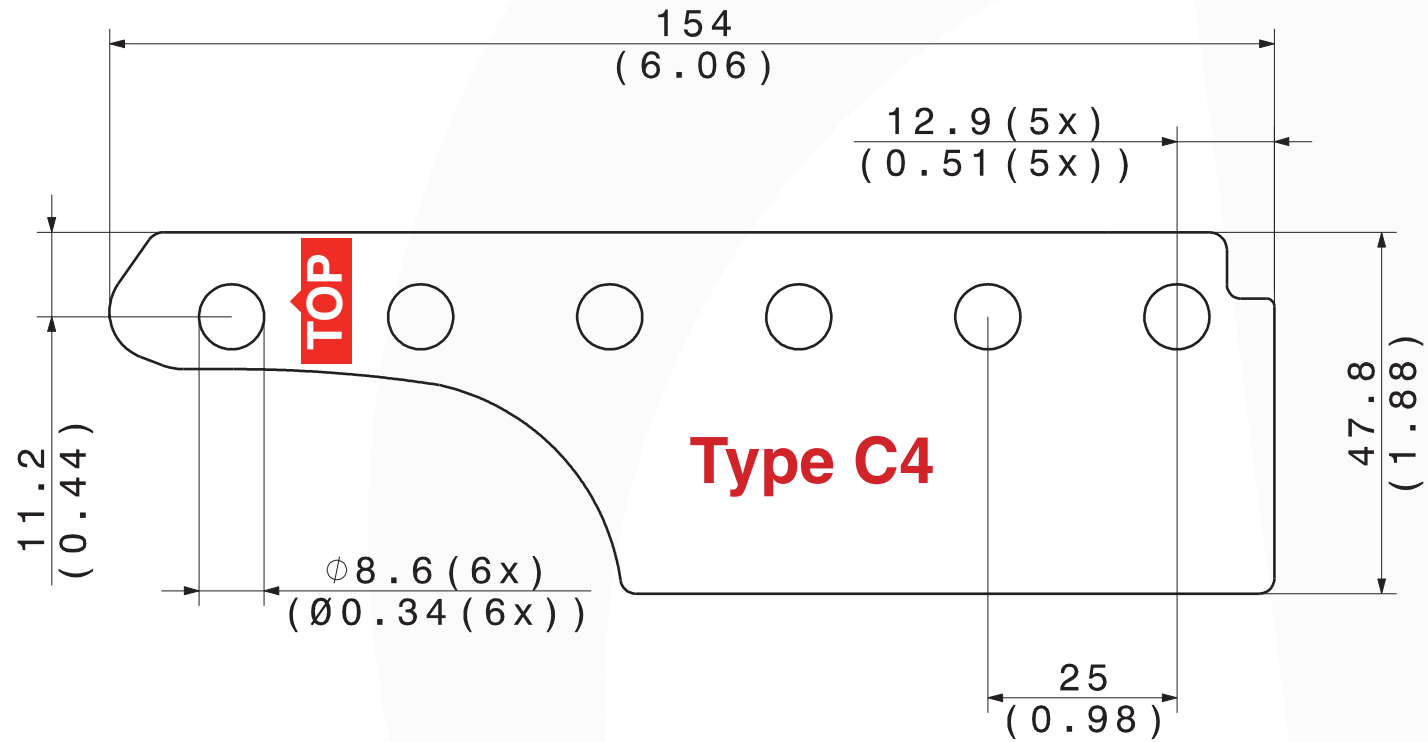
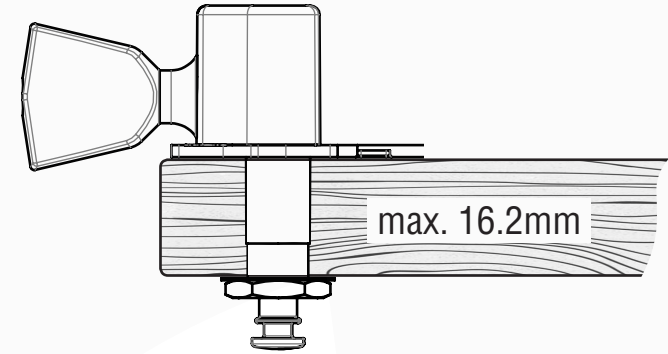

PLACE RULER HERE

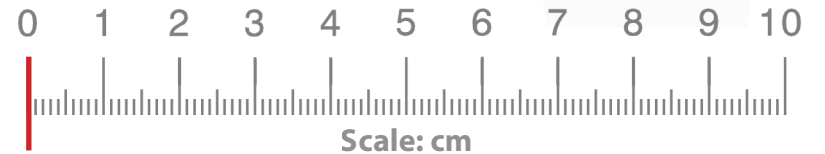

Type C5

Peavey
Riptide Black

Fender Squier
Strat Affinity

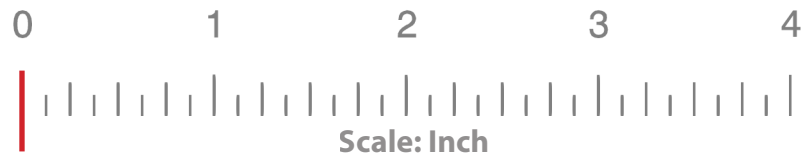
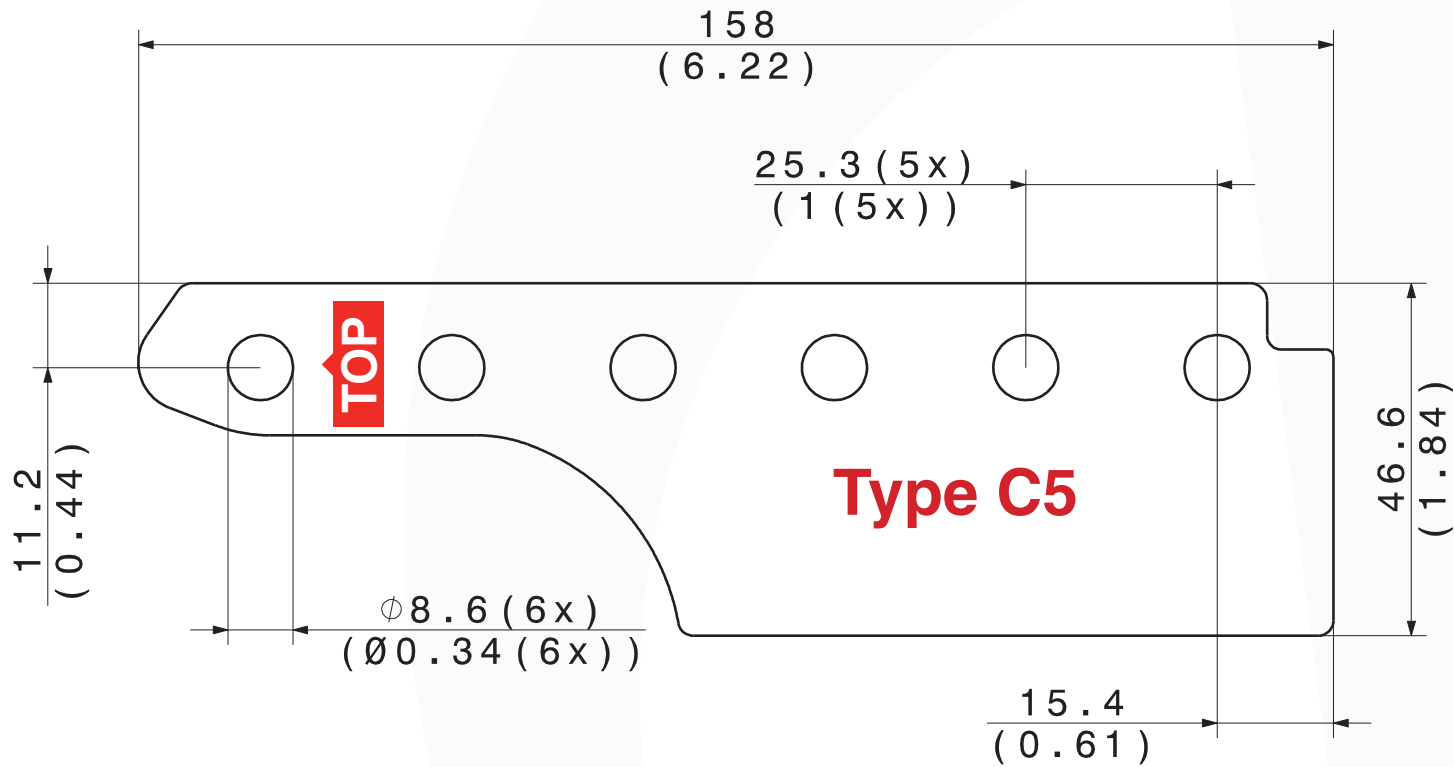
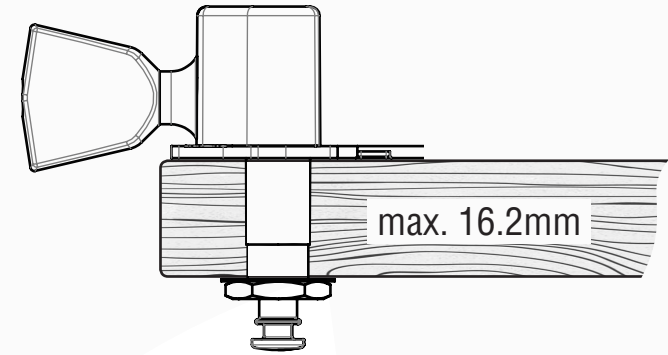

Scale: Inch

PLACE RULER HERE

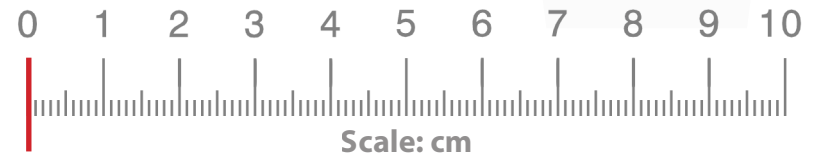

Scale: cm



TRONICALTUNE PLUS

Template Types



There are different templates available for this Headstock – check which one fits your guitar following the guide below:

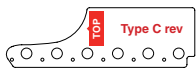

1. Printer Settings:

- Size Setting: 100%
- Page Adaption: None
- Page Scaling: None



2. Place a ruler onto the printed templates to check correct printout size

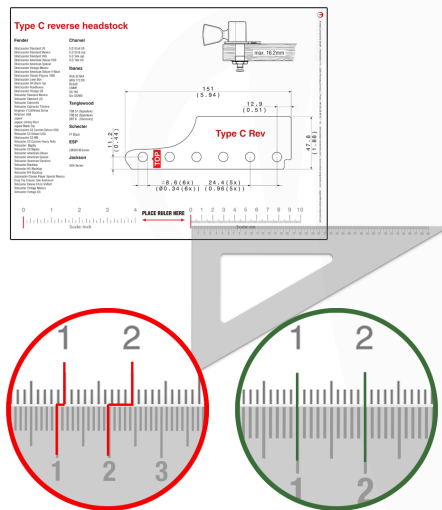

3. Cut-out the templates

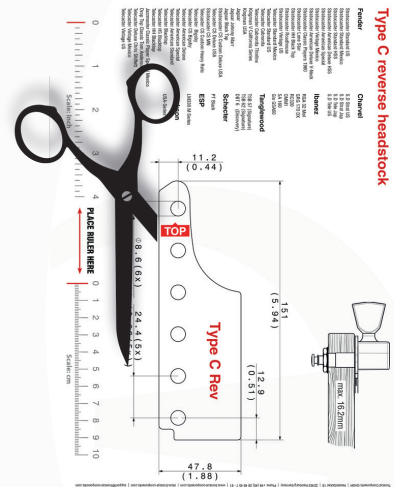

4. Place the templates on the back of your guitar headstock. Check if the holes of the template are congruent to the holes of your guitar. When they are congruent you identified the template that fits your guitar. Enter this type during the order process.

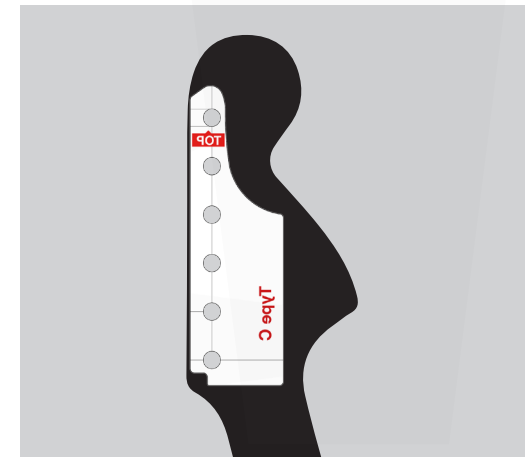

Type C reverse headstock

Fender

- Stratocaster Standard US
- Stratocaster Standard Mexico
- Stratocaster Standard HSS
- Stratocaster American Deluxe HSS
- Stratocaster American Special
- Stratocaster Vintage Mexico
- Stratocaster American Deluxe V-Neck
- Stratocaster Classic Players 1960
- Stratocaster Lone Star
- Stratocaster HH Black Top
- Stratocaster Roadhouse
- Stratocaster Vintage US
- Telecaster Standard Mexico
- Telecaster Standard US
- Telecaster Cabronita
- Telecaster Cabronita Thinline
- Kingman V California Series
- Kingman USA
- Jaguar
- Jaguar Johnny Marr
- Jaguar Black Top
- Stratocaster CS Custom Deluxe USA
- Telecaster CS Deluxe USA
- Stratocaster CS MN
- Telecaster CS Custom Heavy Relic
- Telecaster Bigsby
- Telecaster CS Bigsby
- Telecaster American Deluxe
- Telecaster American Special
- Telecaster American Standard
- Telecaster Blacktop
- Telecaster HS Blacktop
- Telecaster HH Blacktop
- Jazzmaster Classic Player Special Mexico
- Drop Top Classic Tom Anderson
- Telecaster Deluxe Chris Shiflett
- Telecaster Vintage Mexico
- Telecaster Vintage US

Charvel

- S.D Strat US
- S.D Strat Jap
- S.D Tele Jap
- S.D Tele US

Ibanez

- RGA 32 Mol
- GRG 170 DX
- RC320
- CMM1
- SA 160
- Gio GSA60

Tanglewood

- TSB 57 (Signature)
- TSB 62 (Signature)
- DBT 6 (Discovery)

Schecter

- PT Black

ESP

- LM330 M Series

Jackson

- USA-Series

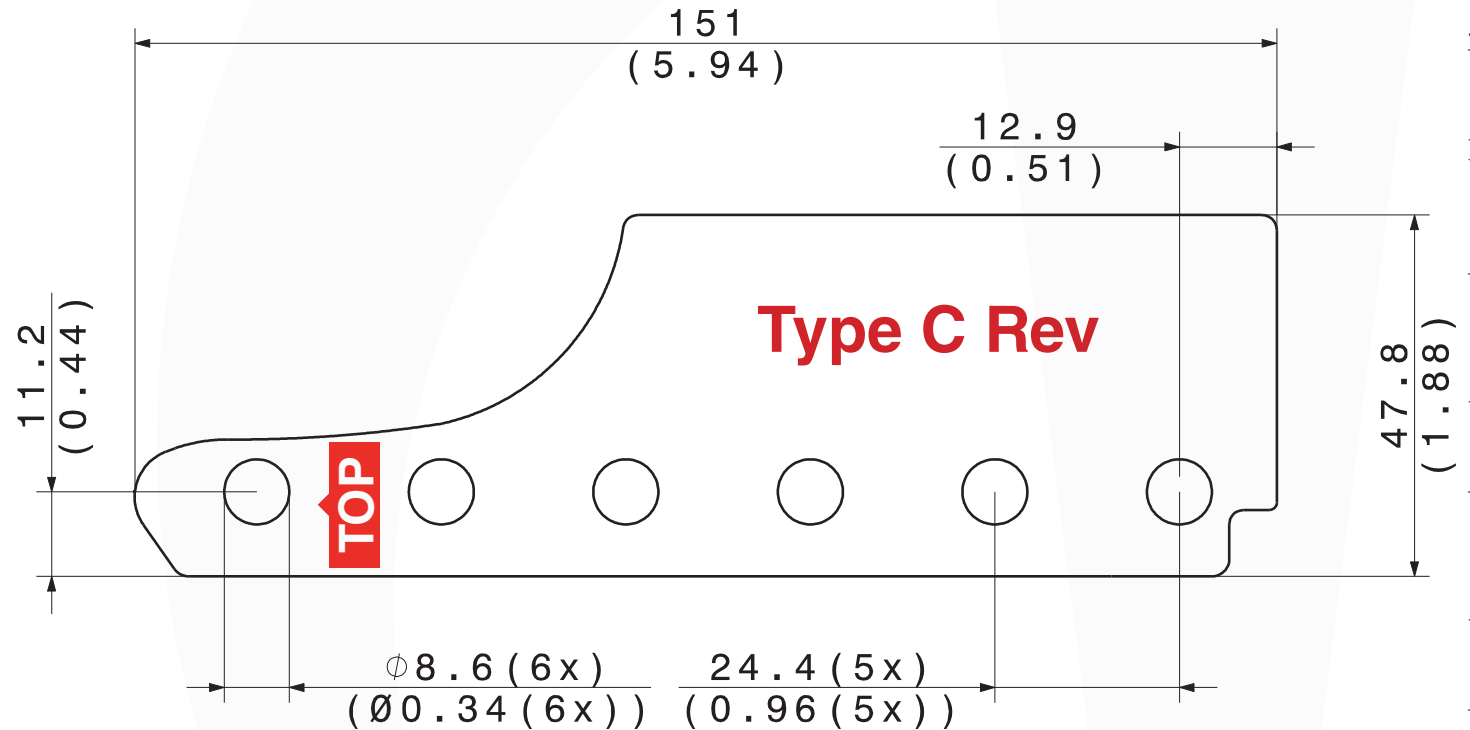
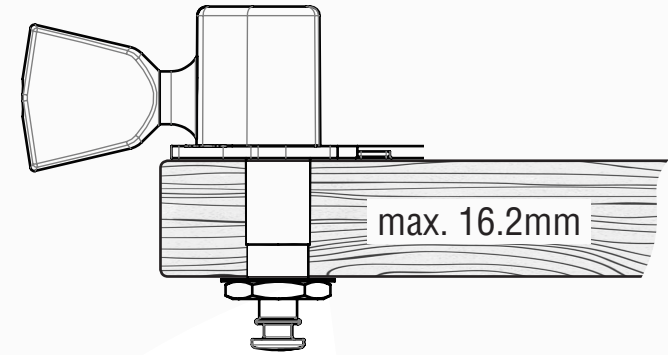

Type C1 Reverse headstock

Fender

Telecaster CS Thinline 1950
 Telecaster CS Butter Scotch 1952
 Telecaster Relic 1952
 Telecaster Classic Vibe 1960
 Telecaster Classic Vibe Butterscotch Blond 1960
 Telecaster Thinline Classic Vibe 1960
 Telecaster CS Masterbuild 1964
 Telecaster CS Paisley Logo 1970
 Telecaster TY Yellow
 Telecaster Richie Kotzen
 Stratocaster CS Fiesta Red 1950
 Stratocaster NOS Holoflake 1950
 Stratocaster Classic Vibe 1950
 Stratocaster CS Tao Turquoise 1956
 Stratocaster Relic HSS 1957
 Stratocaster NOS 1957
 Stratocaster CS NOS active 1957
 Stratocaster CS Close Classic Masterbuild 1957
 Stratocaster CS Hardtail 1957
 Stratocaster CS Fiesta Red 1960
 Stratocaster Classic Vibe 1960
 Stratocaster CS Doutone Relic 1960
 Stratocaster CS Heavy R 1962
 Stratocaster CS closed classic 1965
 Stratocaster Heavy 1968
 Stratocaster CS Robert Cray
 Mustang
 Telecaster La Cabronita „F“ Hole MN
 Sonoran SCE
 Telecaster Vintage Modified
 Jazzmaster Vintage Modified
 Mustang Vintage Modified
 Jaguar Vintage Modified

Fender Squier

Stratocaster Models Indonesia
 Telecaster Vintage Modified „La Cabronita“ Indonesia
 Stratocaster Classic Vibe China
 Telecaster Classic Vibe China

Lag

Arkane Series 66
 Arkane Series 100
 Arkane Series 200
 Arkane Master 3000
 Master Special Edition

Yamaha

Pacifica (all Modells)

Ibanez

BBM1
 RGIR Serie
 RG370
 RG
 RGR
 RG321
 S 770 PM
 SIR70FD
 S5470 - Serie
 RG440
 S970CW
 JEM Series
 SA960QM
 RG550XH

Warmoth

Strat style

Vox

Apache 1

James Tyler

JTV 69 Variax

John Suhr

Pro Series

Swing

R Series

Hamer

Slammer Series

Moolon

S Classic

Mike Lull

Electric guitars

Godin

Session - Serie
 Progression - Serie
 Freeway Classic

Schecter

Stratocaster Traditional Series
 Telecaster PT Vintage Series
 California Custom Elite

ESP

E-2 Vinatage Plus
 E-2 Vintage Tele
 LEX50BLK EX

LTD

ST-213
 ST-213 FR
 TE-212

Agostin

Drop Top Custom
 Classic S2
 Classic Korina S3
 Classic Korina S4
 Classic V2
 Art Series Z 24
 Custom Z24
 Classic T
 Classic T Nashville
 Classic T Nashville Tremolo
 Zoe

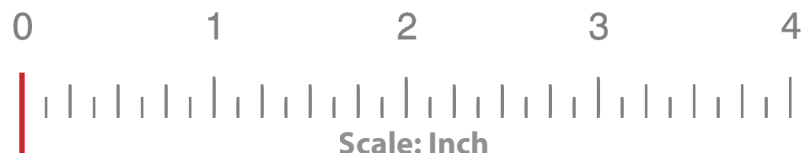
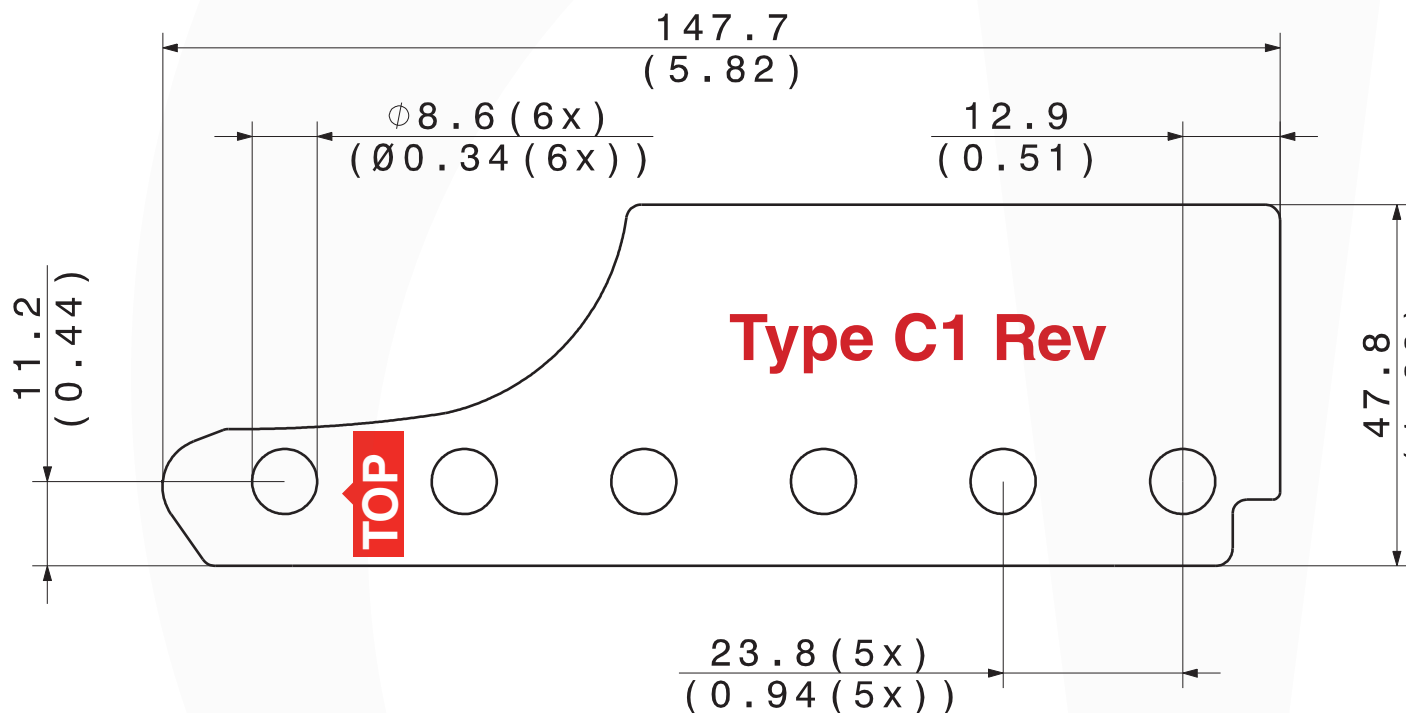
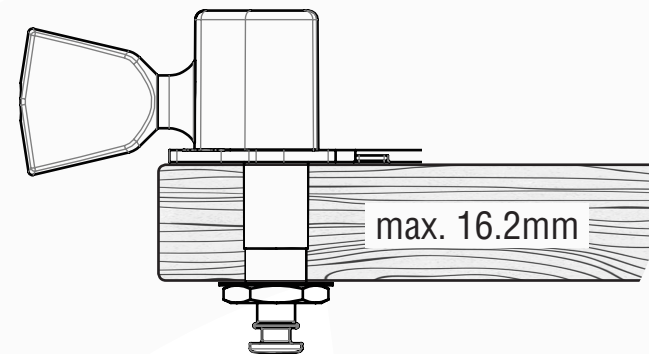

PLACE RULER HERE

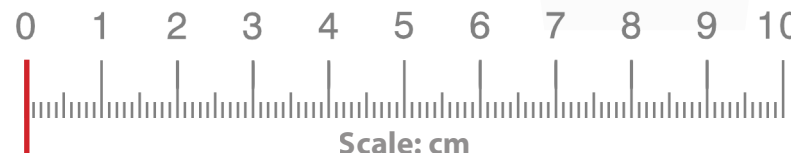

Type C3 Reverse Headstock

Radix
Ironrain

Peavey
Vandenberg

Dean
Zero Trust Dave Mustaine

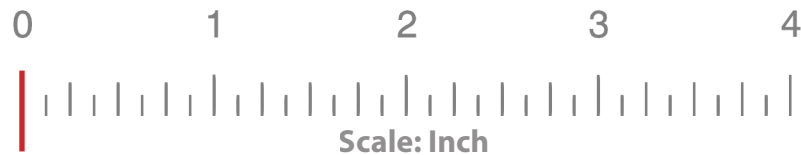
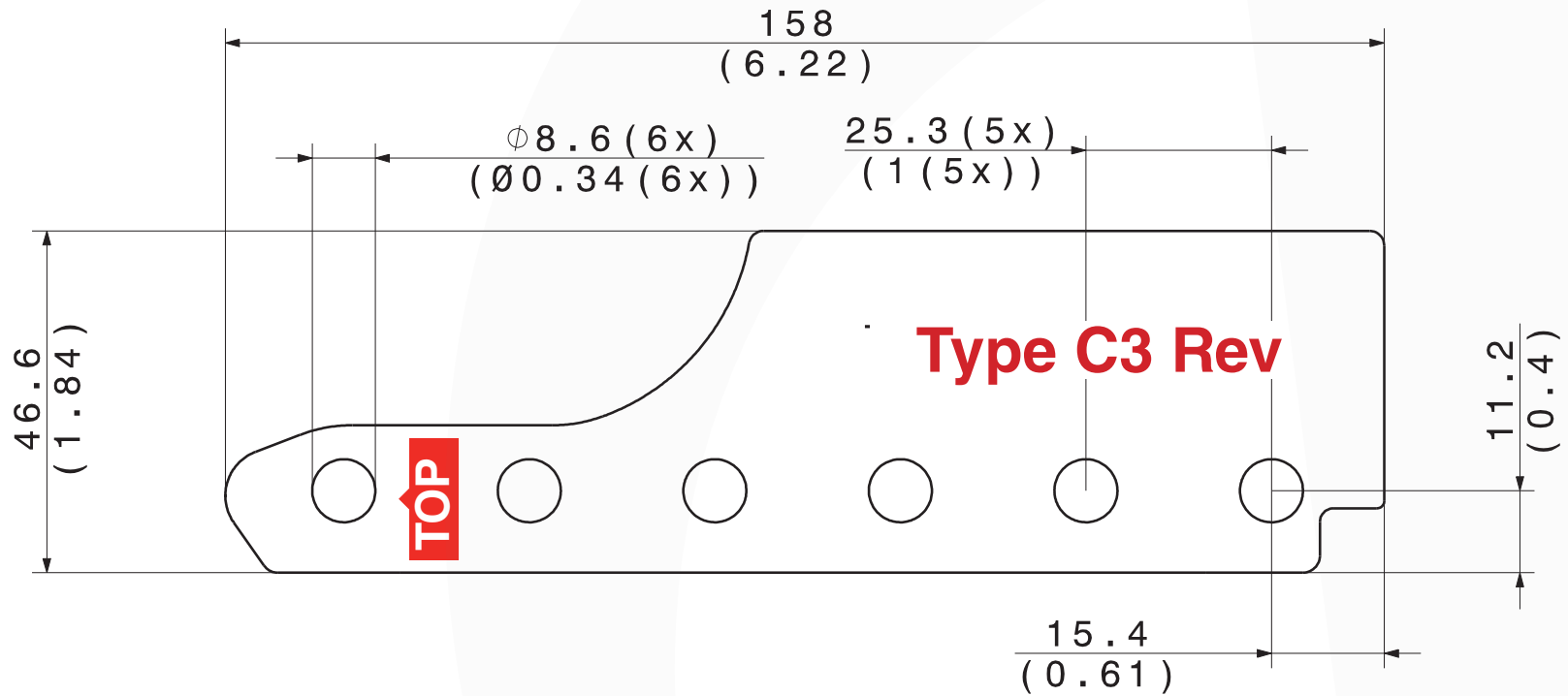
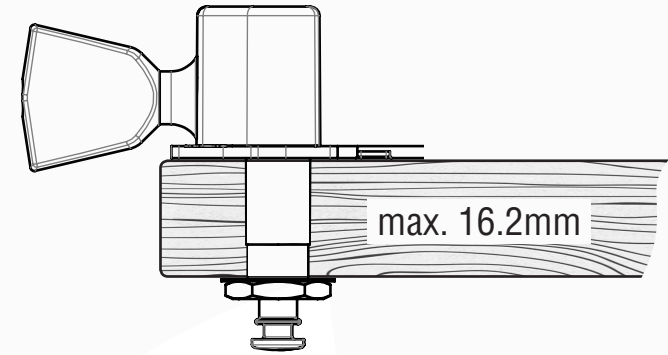

PLACE RULER HERE

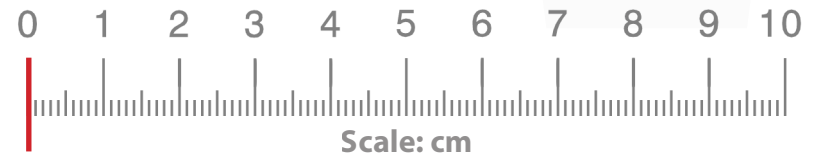

Type D

Gibson

John Lennon Peace
SG Robby Krieger

Vox

Virage 2 Double Cut

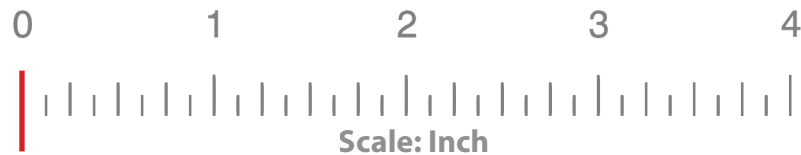
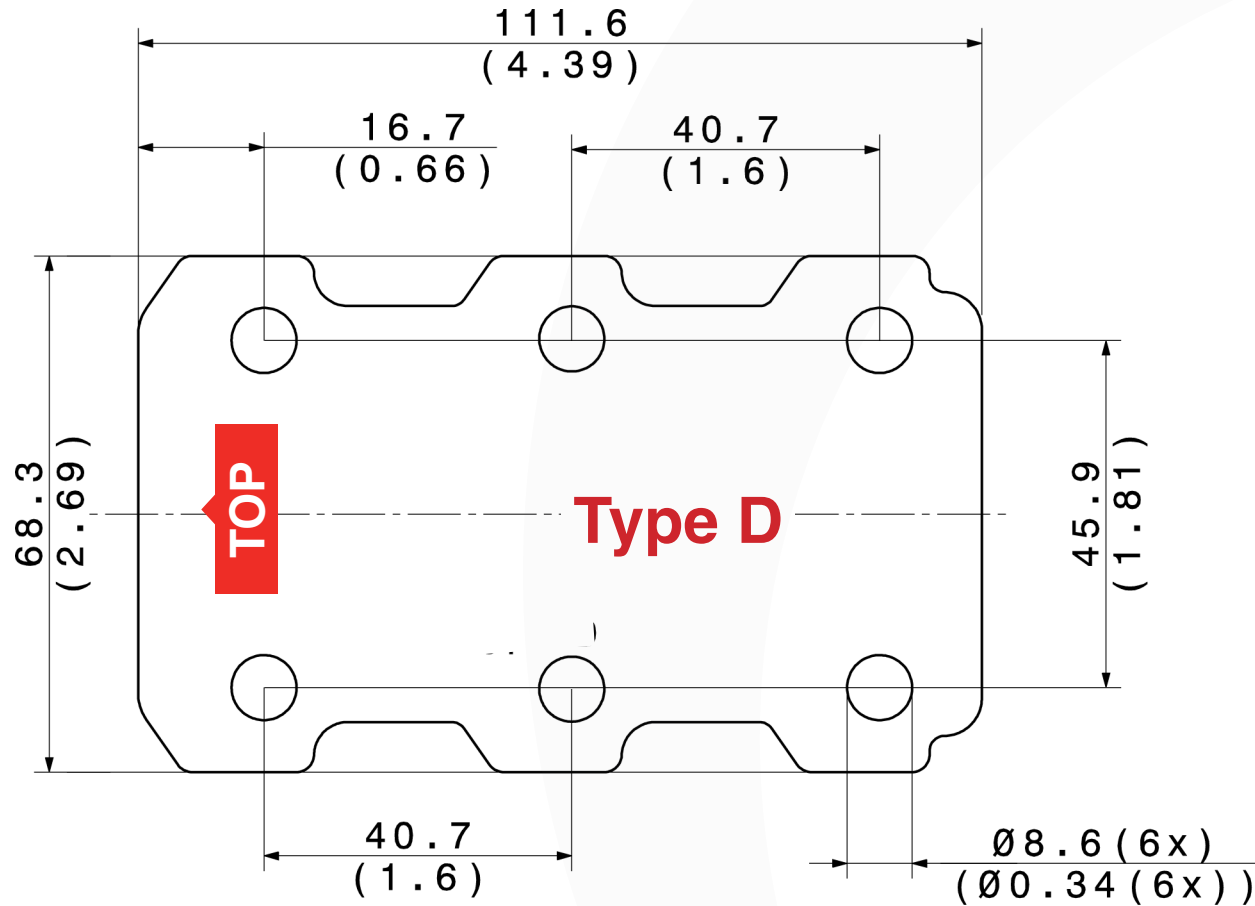
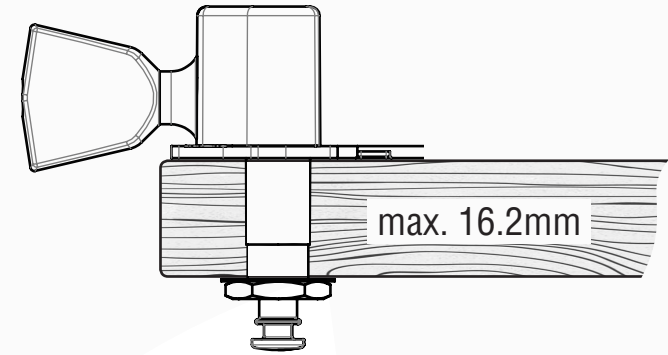

PLACE RULER HERE

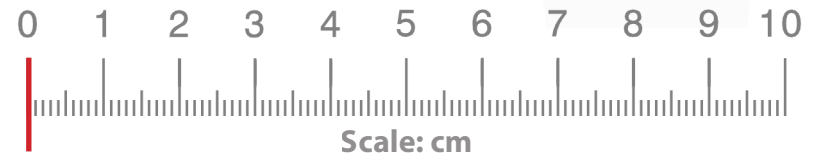

Type E

Gibson

Les Paul Custom VOS 1954
 Les Paul Custom 2 Pickup VOS 1957
 Les Paul Custom 3 Pickup VOS 1957
 Les Paul Custom 50th Anniversary 1960
 Doves In Flight
 J-200 Elvis Presley King of Rock
 ES 345 Lucille
 ES 355 Custom Figured Electric Guitar Bourbon Burst
 Firebird Custom
 J-200 Custom Koa 75th Anniversary
 J-200 Custom
 J-200 New Vintage
 J-200 Studio
 L7-C Acoustic Archtop
 Les Paul Custom Maple
 Les Paul Custom Rosewood Maduro
 Les Paul Custom/ Custom Shop
 Les Paul Supreme
 Artist Dove Elvis Presley ???
 Les Paul Custom Mick Jones
 Montana Gold Flame Maple
 Les Paul Custom Peter Frampton
 Les Paul Custom Randy Rhoads
 SG Custom VOS with Maestro
 SG 61 Reissue Satin
 SG Deluxe Custom
 SG Jeff Tweedy
 SJ 200 Standard
 SJ-200 Pete Townshend
 SJ-200 True Vintage
 J-200 Montana
 Les Paul Custom Nashville (before 2012)
 Les Paul Custom Steve Jones
 Double Cut Custom Tak Matsumoto Ebony
 Les Paul Custom USA Ace Frehley „Budokan“
 Les Paul Custom USA Zakk Wylde Vertigo
 Western Classic Prewar 200
 L-5 CES VS Gibson Custom Shop
 L-5 Wes Montgomery VS Gibson Custom Shop

Epiphone

Les Paul Custom Ace Frehley „Budokan“

FGN

Neo Classic LC Black LP Custom

Gibson

L-5 Wes Montgomery WR Gibson Custom Shop
 L-5 CES N Gibson Custom Shop
 Gibson Midtown Custom
 Les Paul Custom (1974) 20th Anniversary 1954
 L-5 Lee Ritenour
 ES-137 Classic Split Diamond Overlay
 Byrdland Florentine
 SG 70' Tribute
 Les Paul Custom Bullseye Zakk Wylde

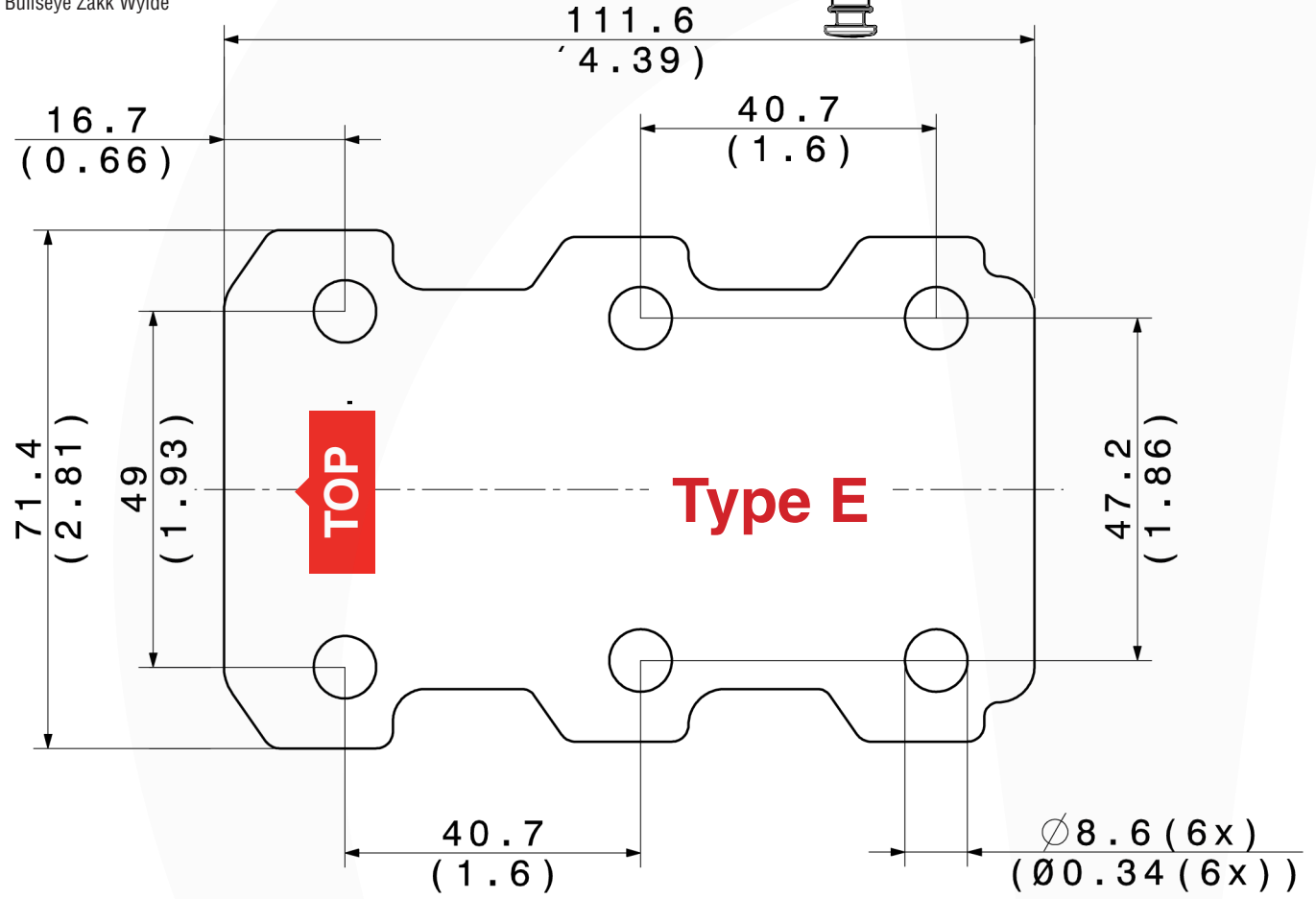
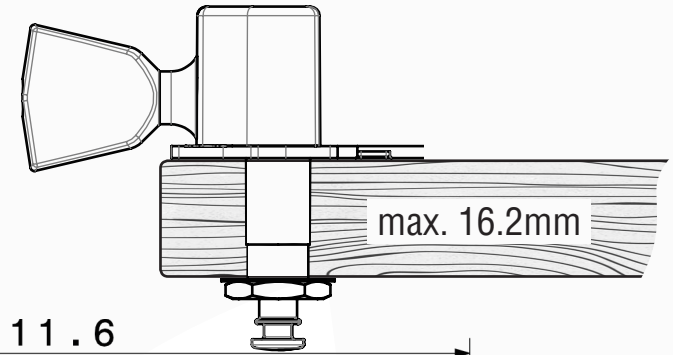

TOP

Type E

PLACE RULER HERE

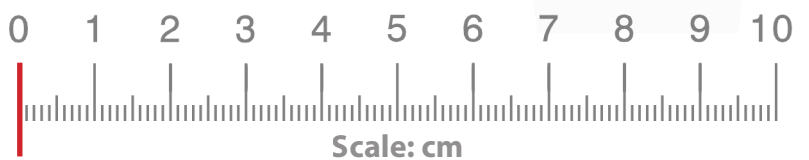
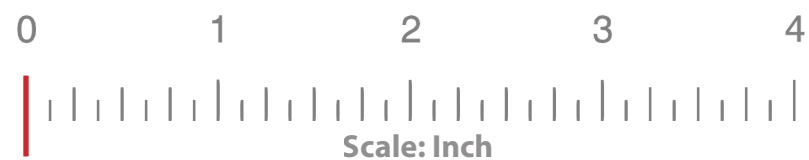

Type E1

Gibson

Les Paul Black Beauty 1959

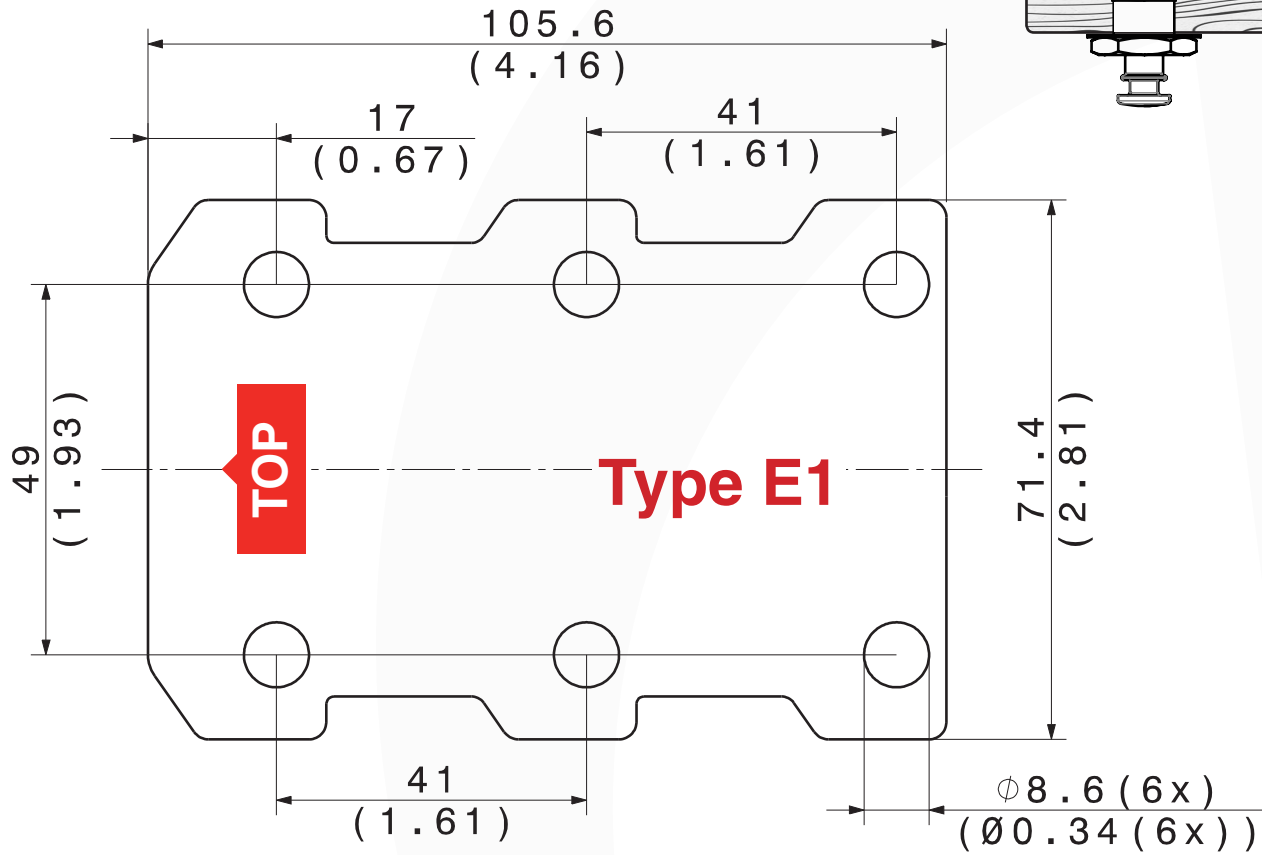

Type E2

Lag

Tramotane T100 ACE

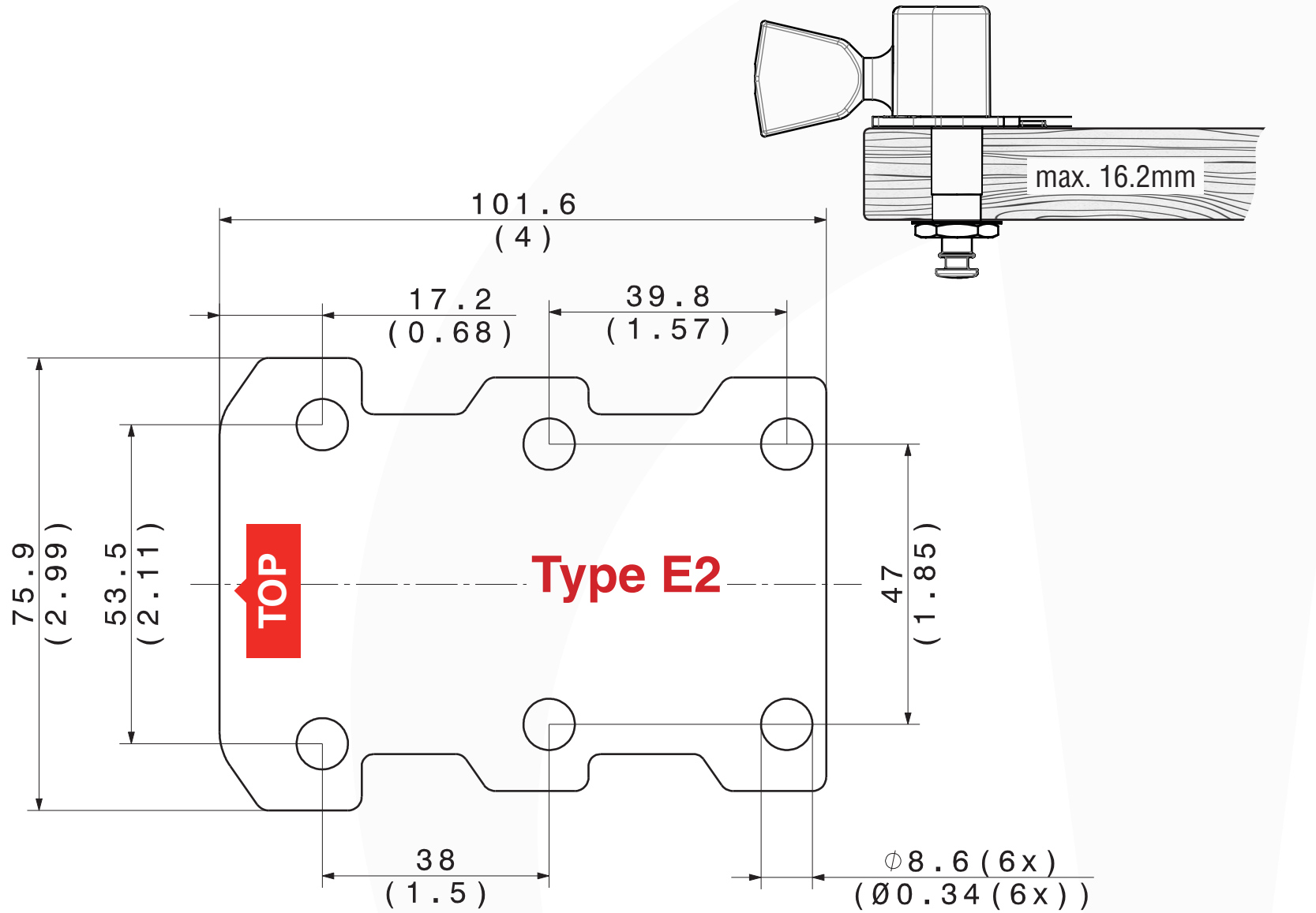

Type F

Taylor

GS Mini

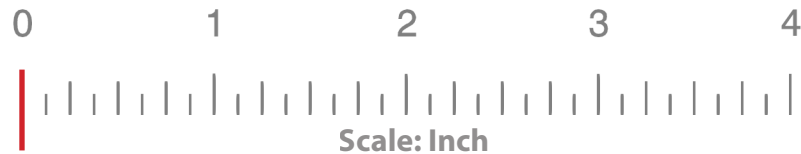
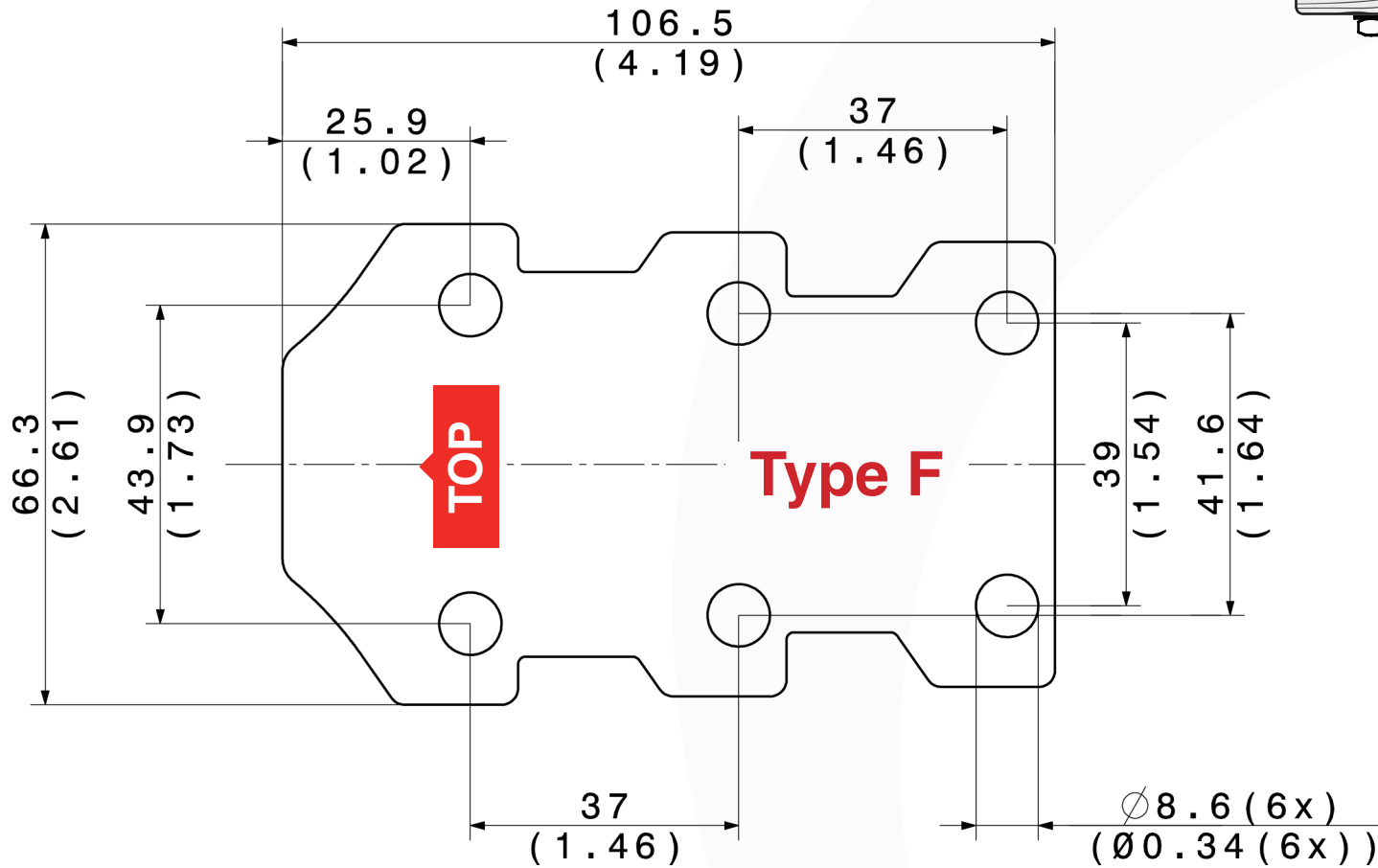
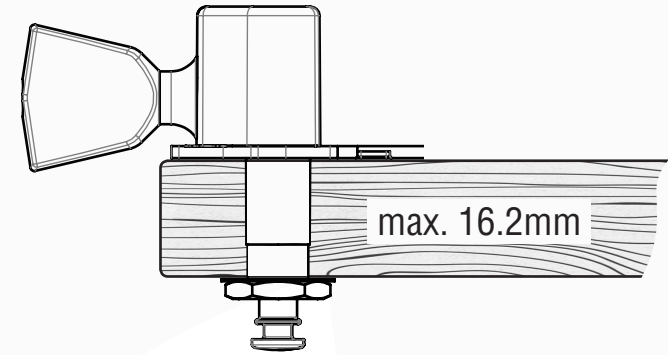

PLACE RULER HERE

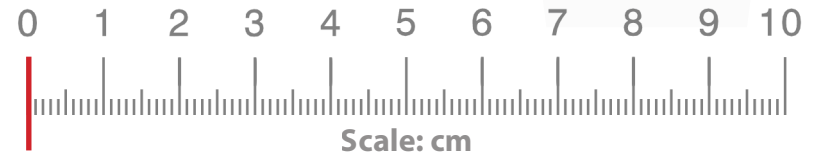

Type G

Yamaha

A series
APX series
FG series
FG700MS

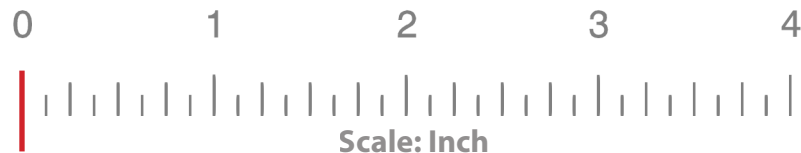
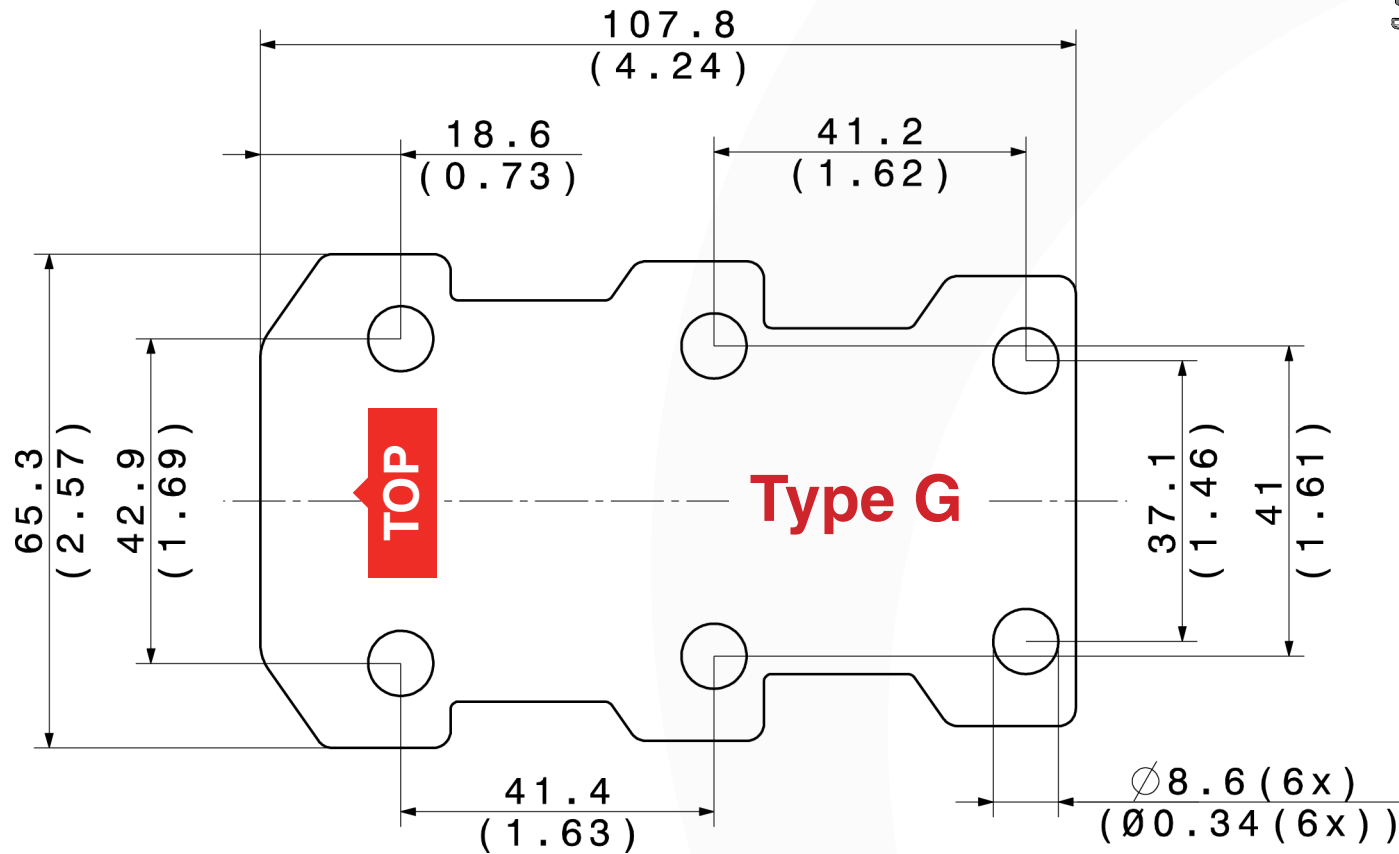
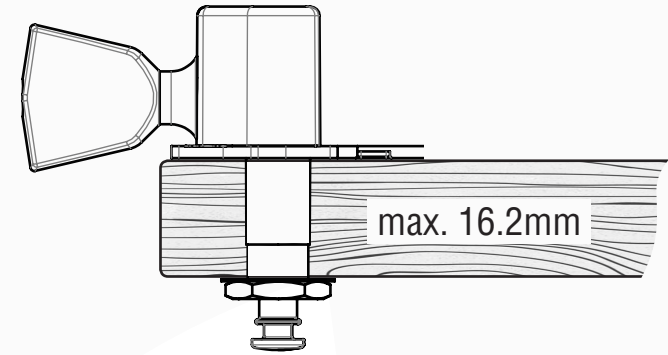

PLACE RULER HERE

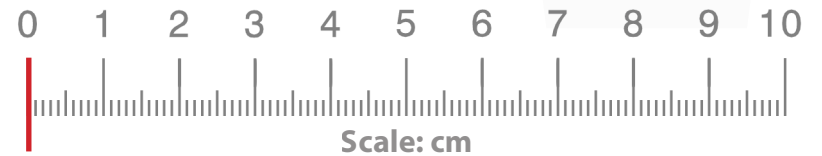

Type H

Taylor

110 (right handed)
 210 ce
 214 Series
 214ce
 310 ce
 312ce
 314 ce
 316ce
 320
 320e
 322e
 324ce
 356ce
 410 ce
 412 ce
 414 ce
 414 ce FLTD
 514 ce
 516 ce
 516e FLTD
 518e
 520e
 526ce
 528e
 610e
 612ce
 614ce
 616ce
 618
 618e
 714-CE-LTD
 718e
 814 ce
 816ce
 818e
 910ce
 912e

912ce
 914ce
 916ce
 918e
 Big Baby
 T3 - Serie
 T5- Serie
 T5-X
 T5-Custom
 GC (Grand Concert)- Serie
 Grand Concert BTO (Build to order)
 GS (Grand Symphony) - Serie
 Jumbo Custom BTO (Build to order)
 GT8 Custom
 DN Custom
 TF Custom
 GO Custom
 K28e
 K26ce
 PS10ce
 PS14ce
 BigBaby Taylor
 T3 Bigsby
 DN5e
 Grand Concert BTO Custom
 Jumbo 12 BTO Custom
 Far-East Models
 DN (Dreadnought) - Serie
 GA (Grand Auditorium) - Serie

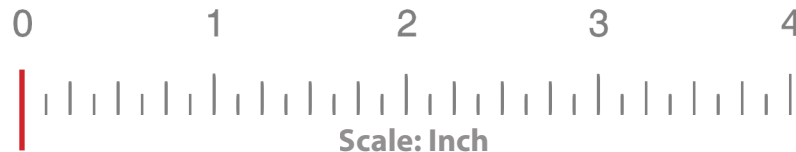
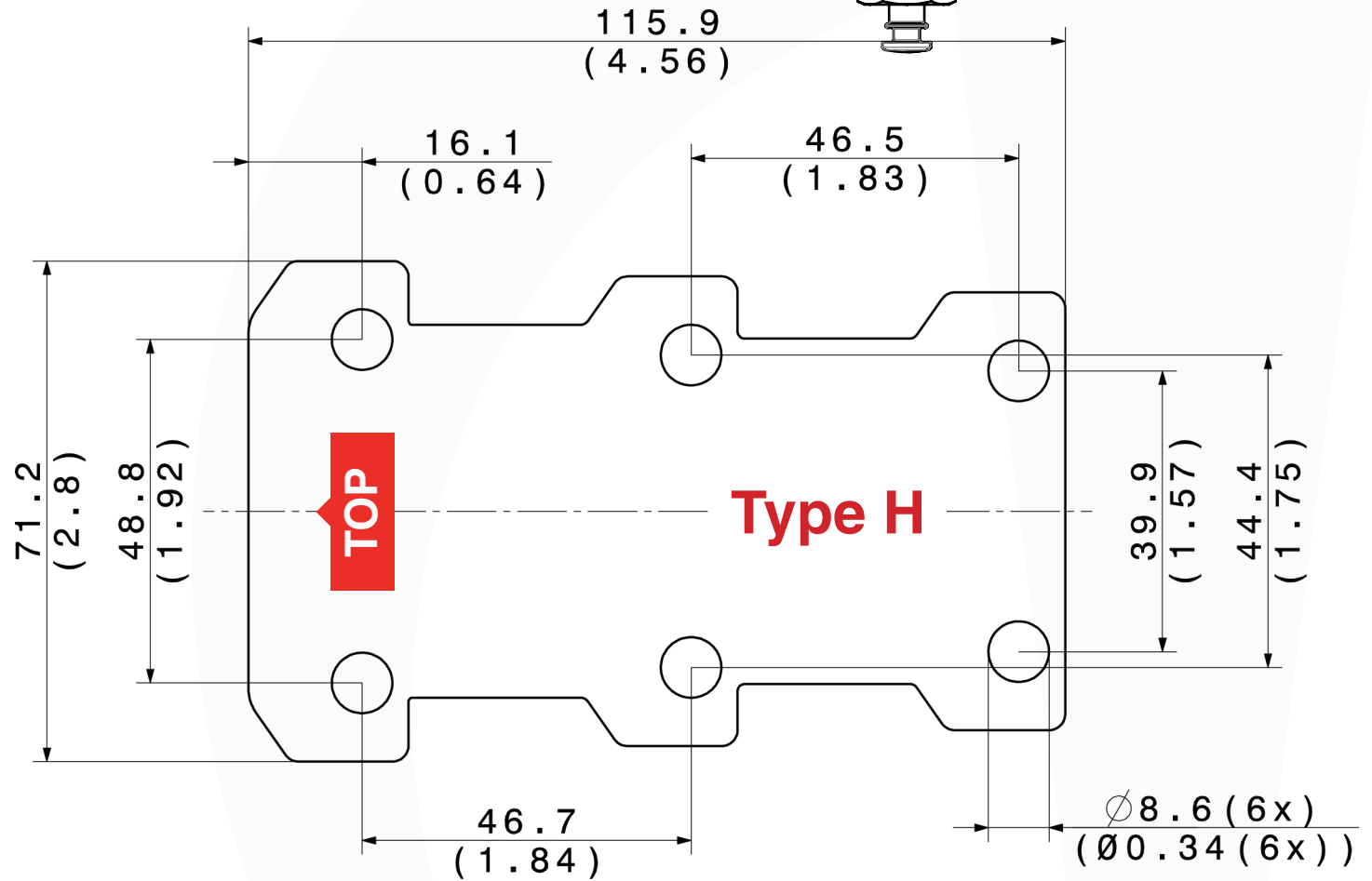
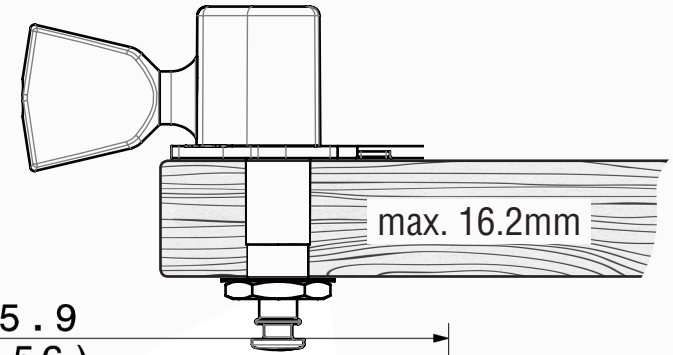

PLACE RULER HERE

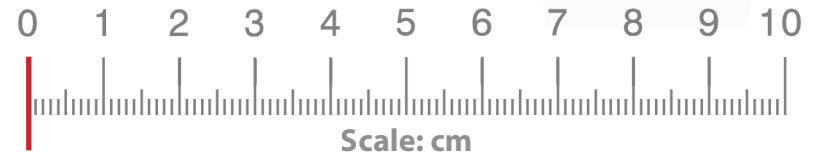

Type H1

Taylor
T5z

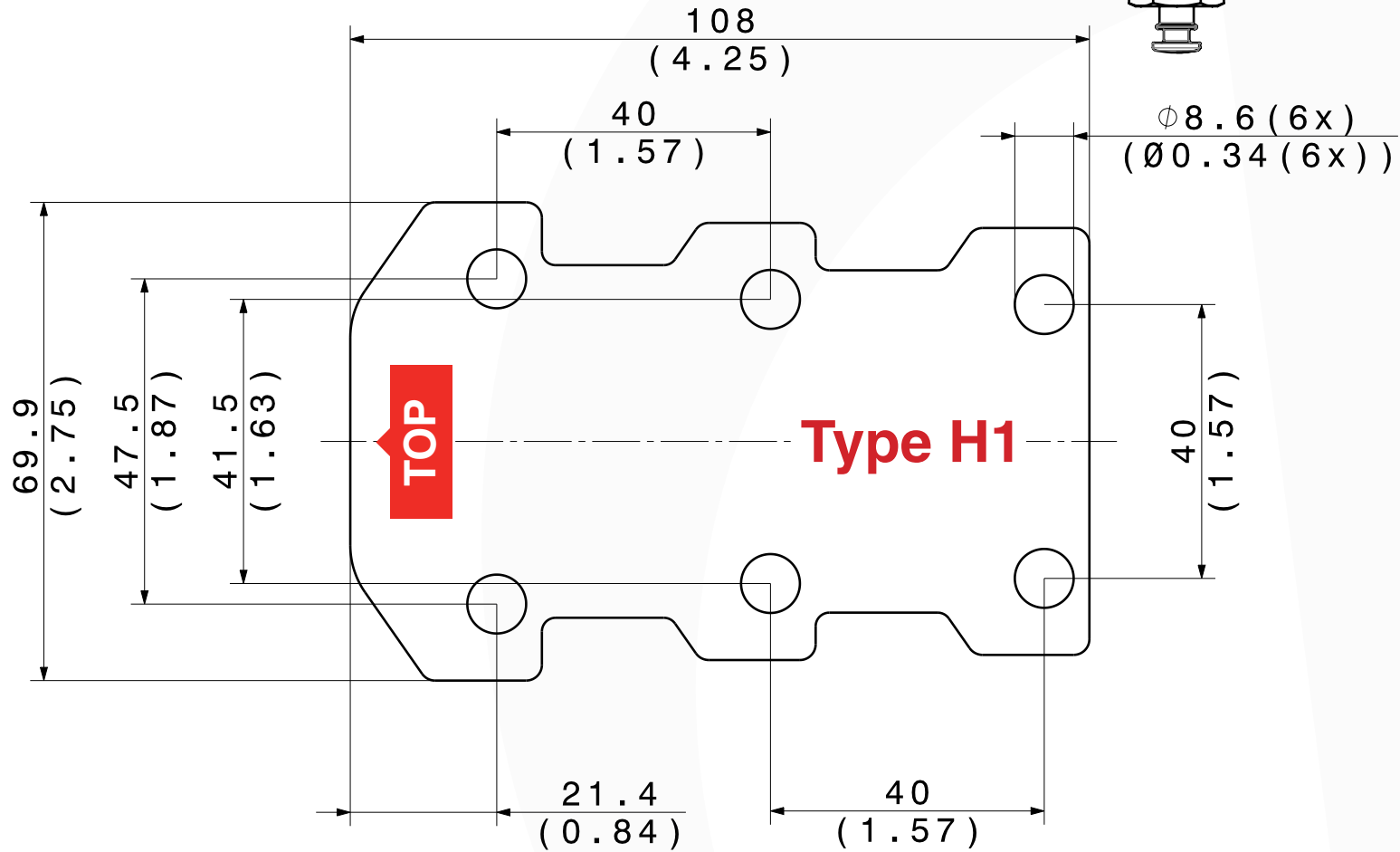
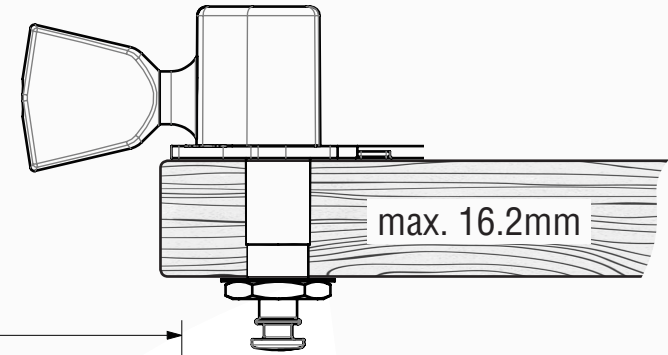

Type I

Ibanez
AW 3050-LG
AC 2040
AC 3000
AW 70
AW 250 ECE
AW 3000
AW 3000-NT
AW 3000 CE
AW 3010
AW 3050 CE

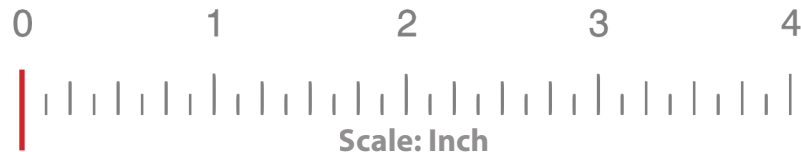
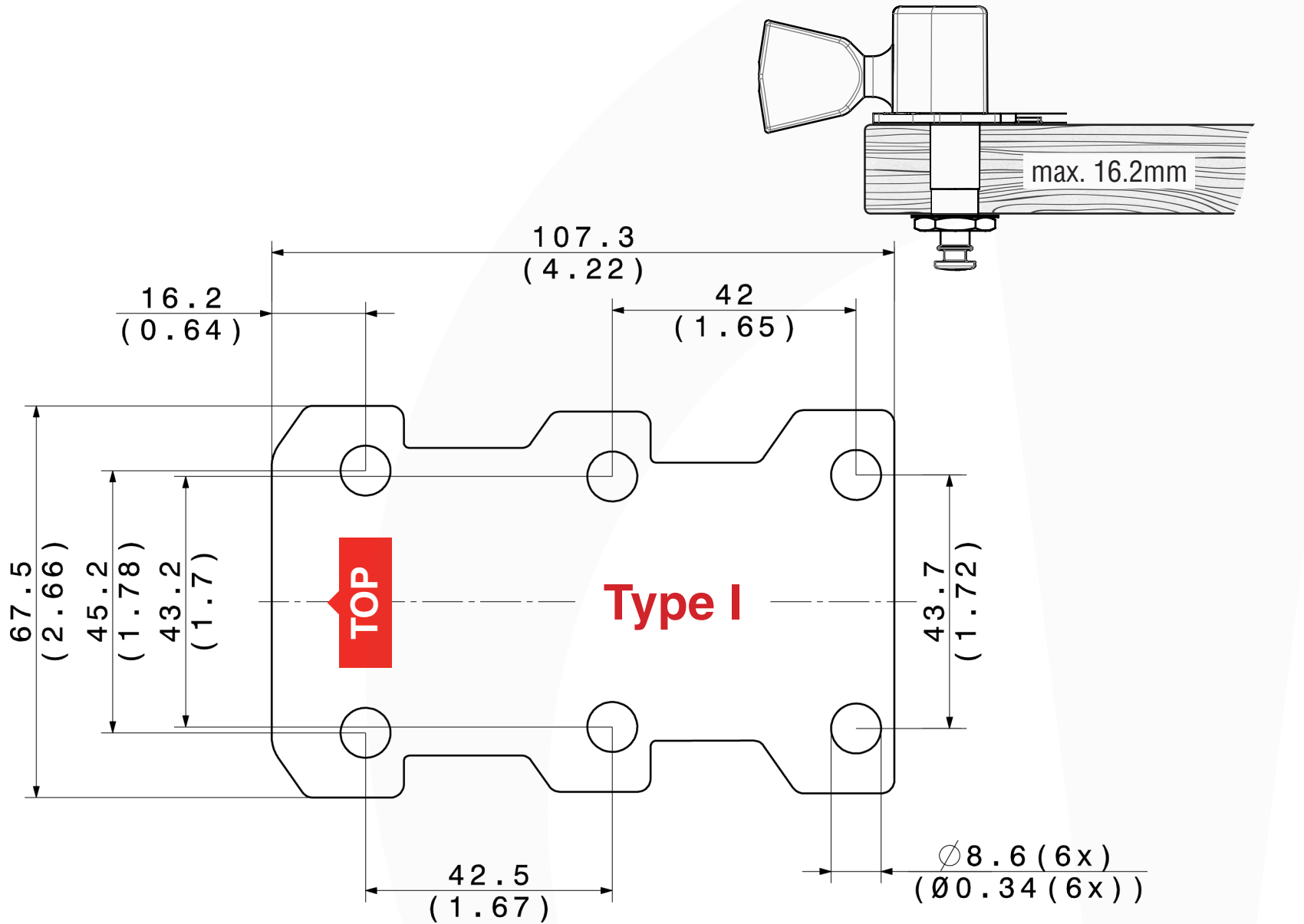

PLACE RULER HERE

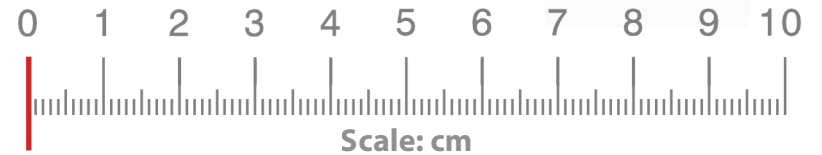

Type J

Epiphone

All Models with Clipped Dovewing

Les Paul Black Beauty

Les Paul Custom Plus

Les Paul Junior

Les Paul Standard

Les Paul Standard Plus

Les Paul Ultra 3

Les Paul Custom Pro

Les Paul Ultra 3

Les Paul Custom Zakk Wylde Bullseye

Les Paul Spaceman Signature Tommy Thayer

Wilshire Phant-O-Matic

G 400 Pro

AJ 220 S

AJ 220 SCE

EJ 200 CE (check Type L as well)

PR 5 Acoustic/Electric

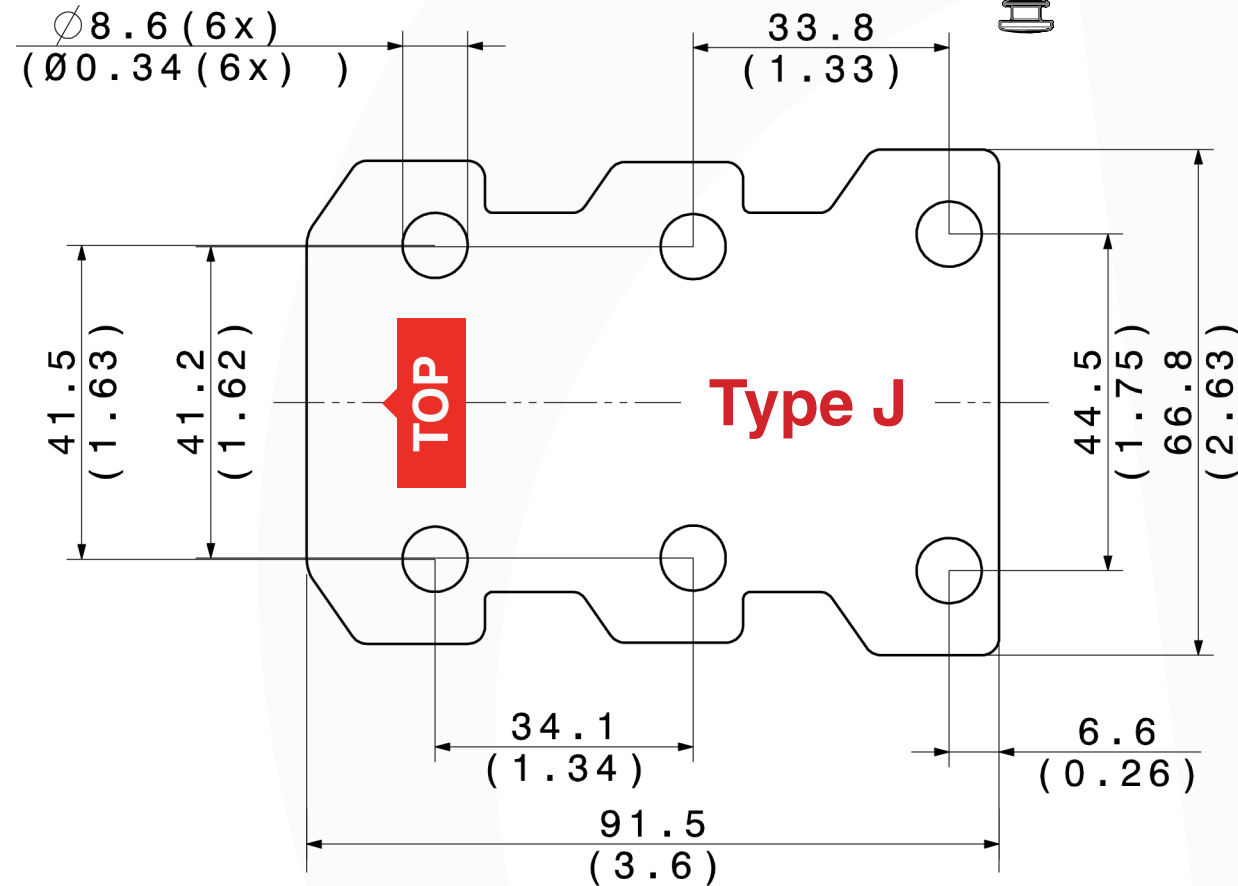
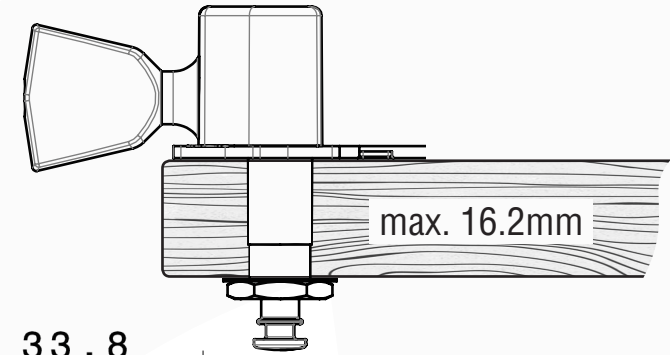

Type L

Epiphone

All Models with Sloped Dovewing

Dot Studio

ES 339

ES 339 Pro

Casino John Lennon

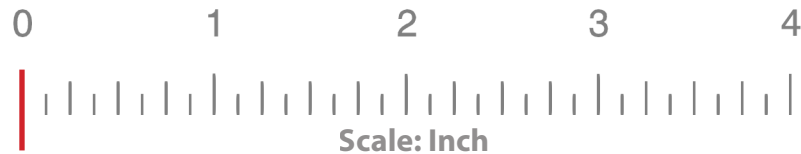
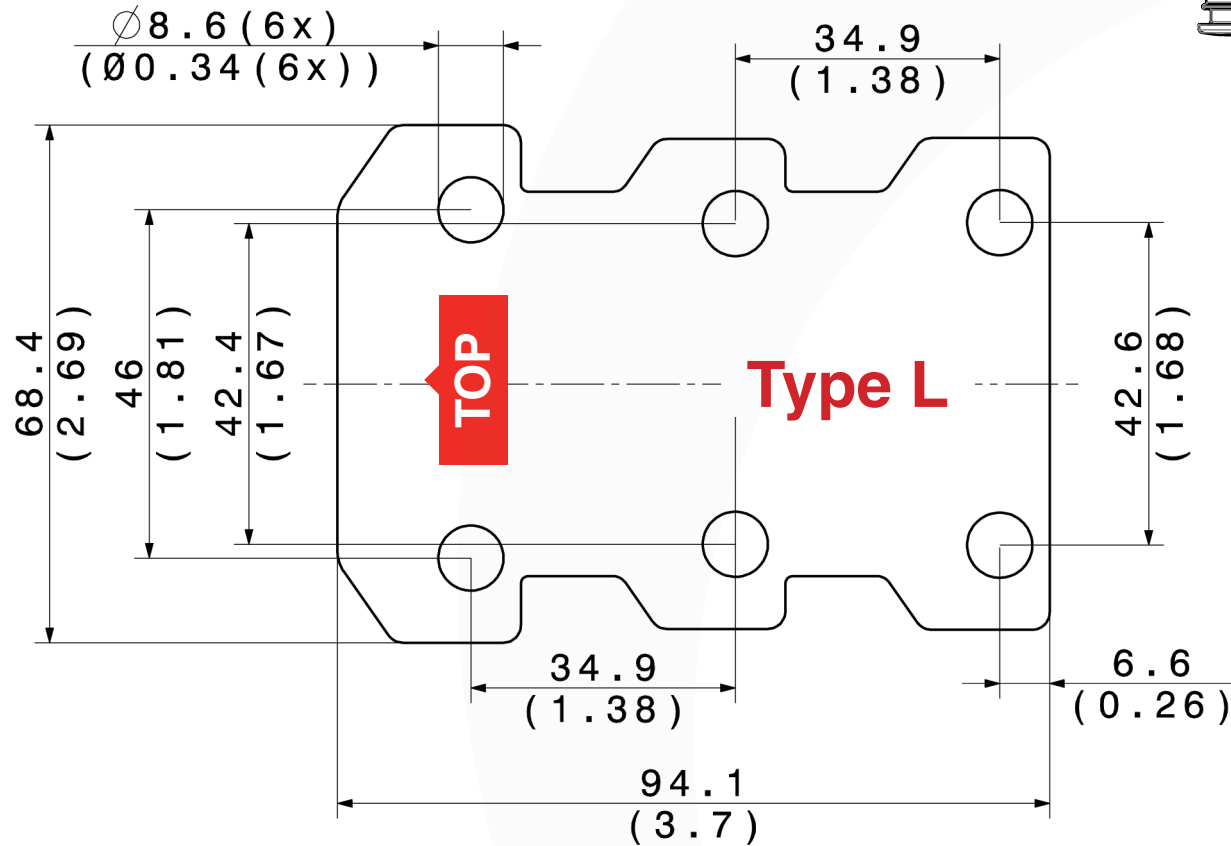
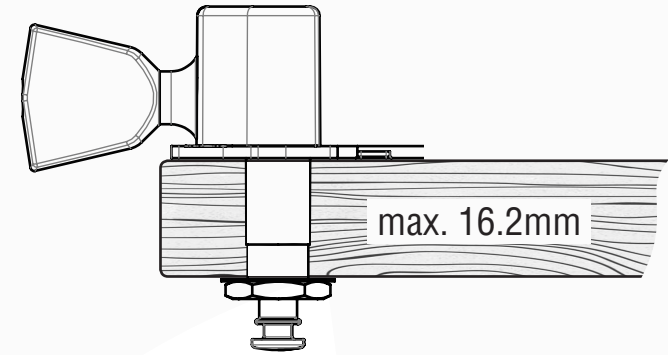

PLACE RULER HERE

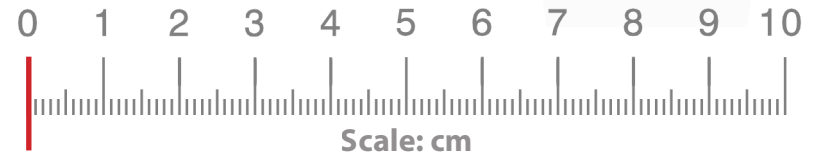

Type M

Guild

- F 20 Standard
- F 30 STD
- F 30 Aragon
- F 30 RCE Standard
- F 40 Valencia
- F 46 R
- F 50 CE
- F 50 R
- F 412 M 120 E
- JF-55
- D 40 Bluegrass Jubilee
- D 50 CE
- D 50 STD
- D 55
- D 125
- D 150 CE

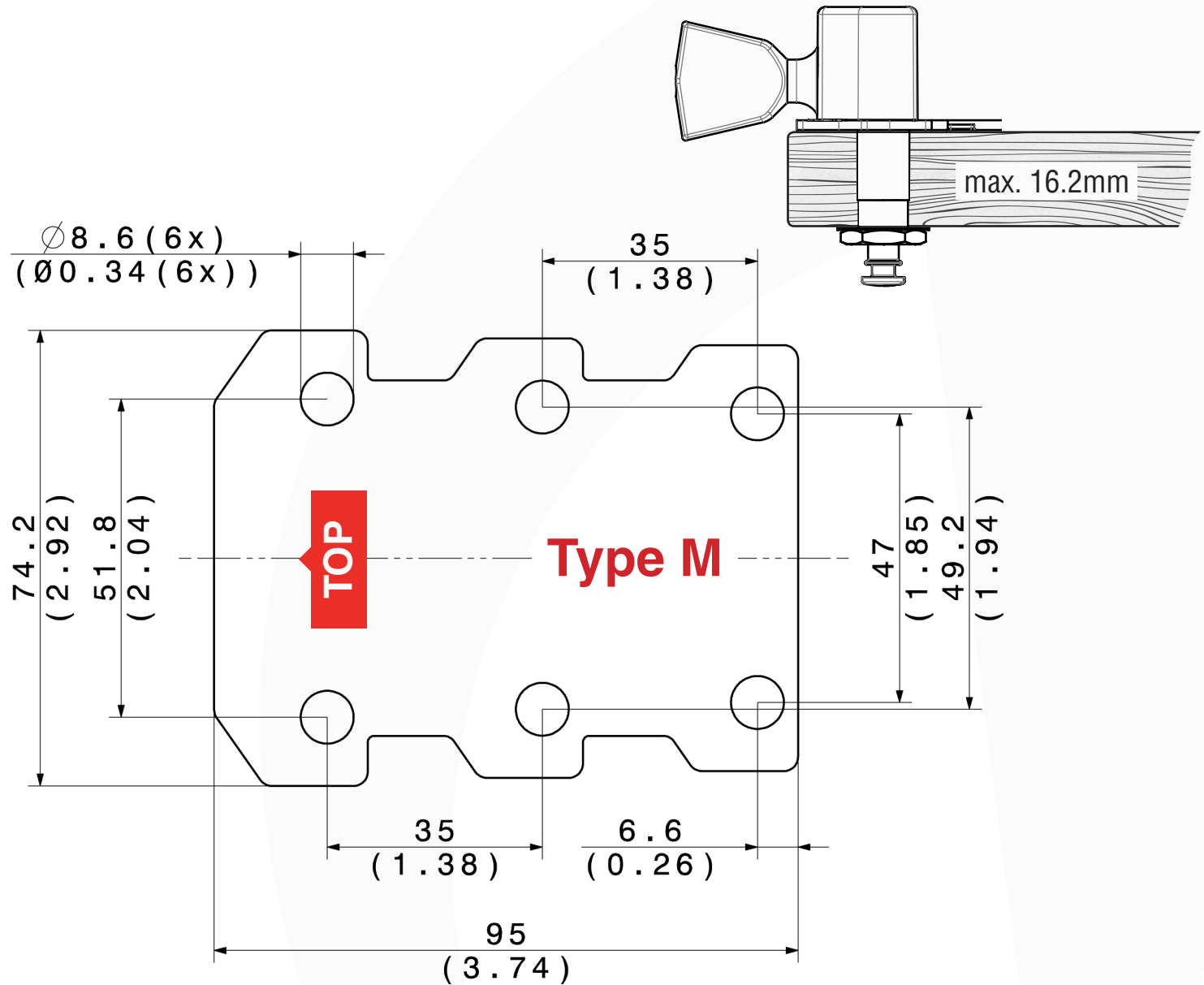

Type N

D'Angelico

Kurt Rosenwinkel

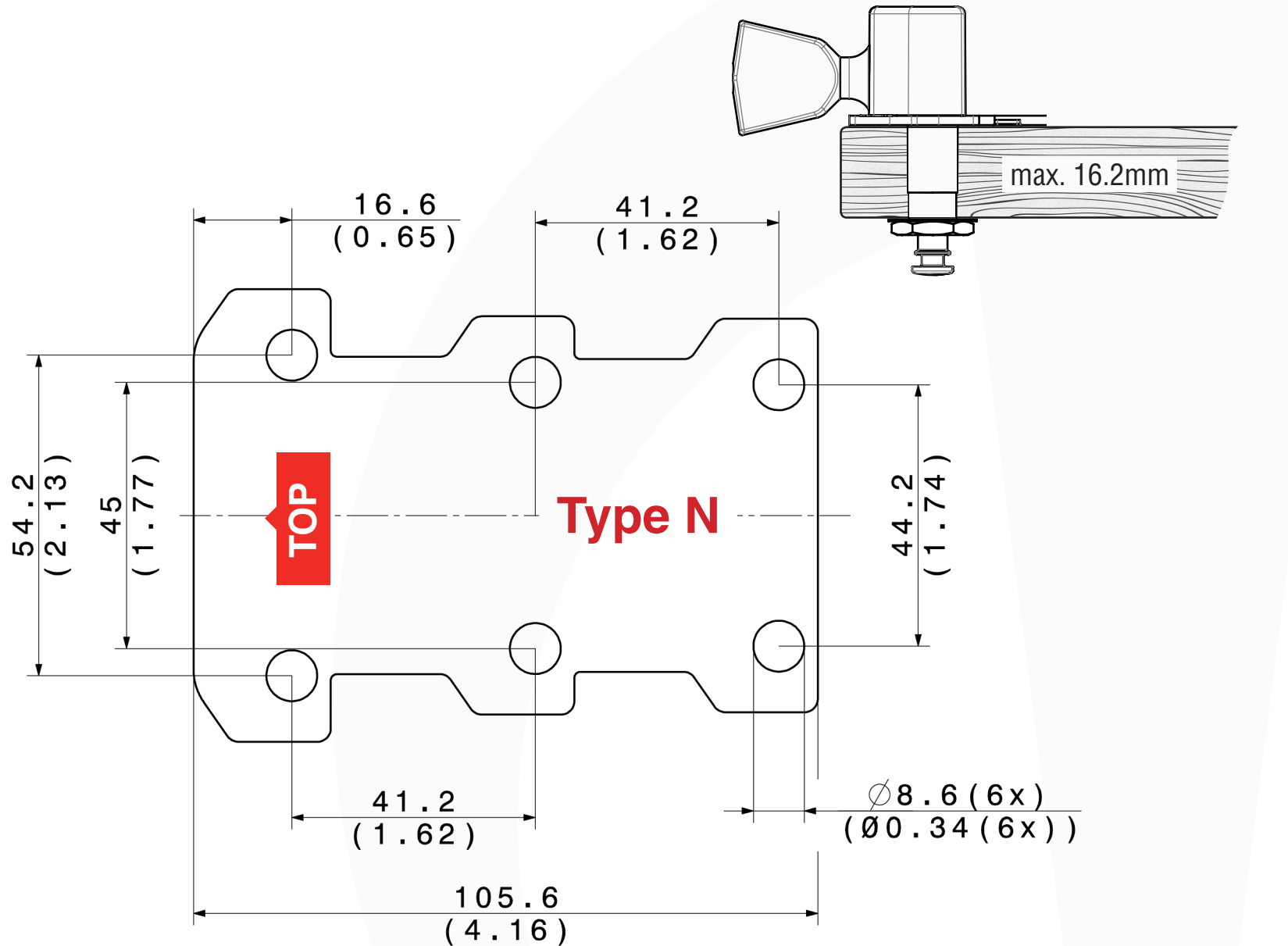

Type O

Cort

AS E4 nat
AS E5 nat
Earth 1200 nat (Valute,Waverly)

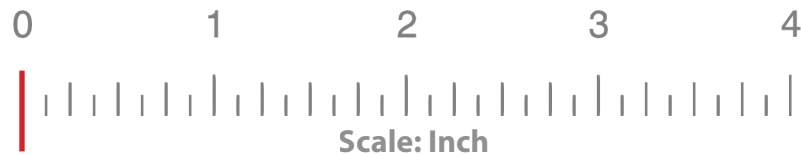
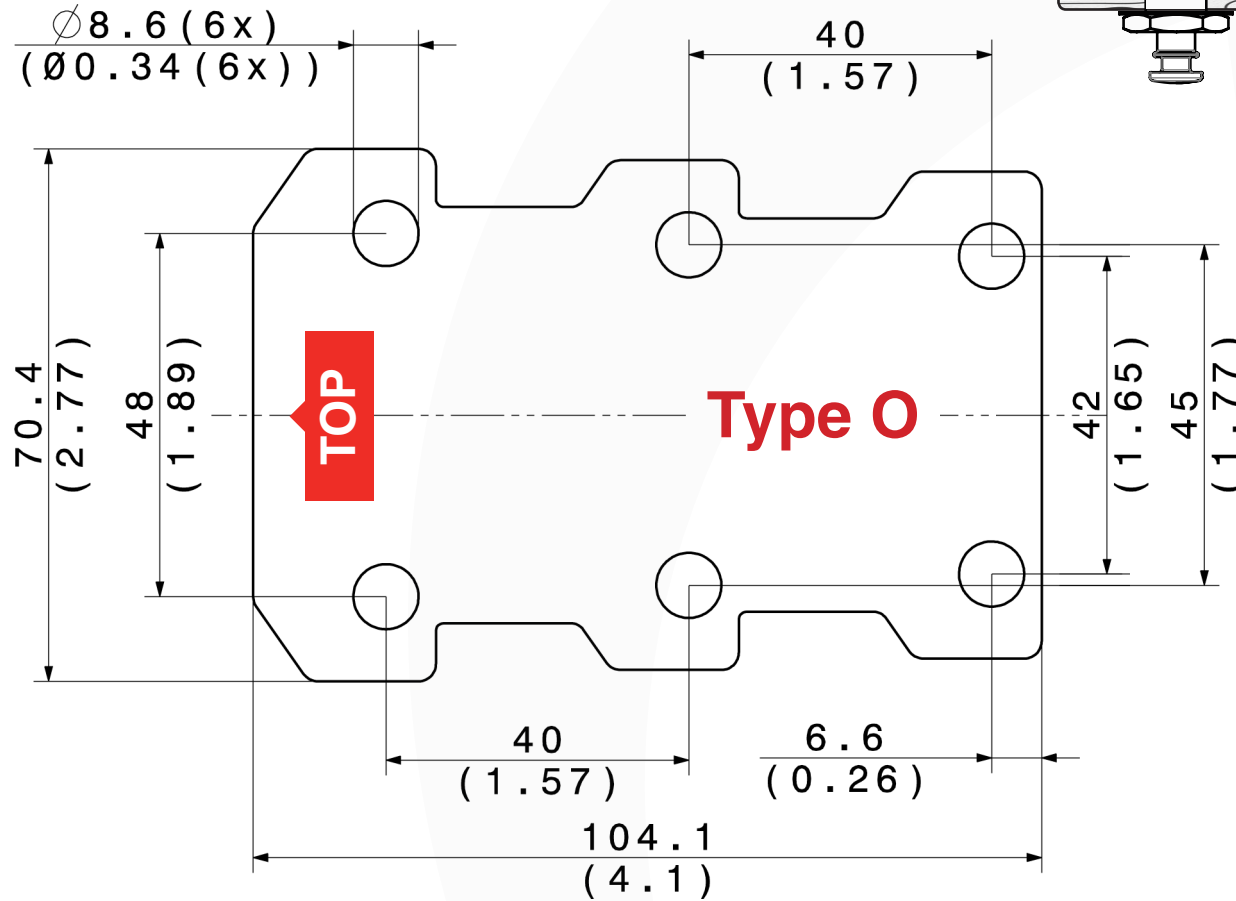
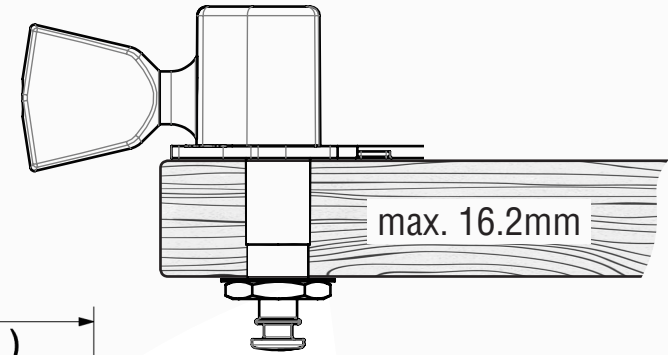

PLACE RULER HERE

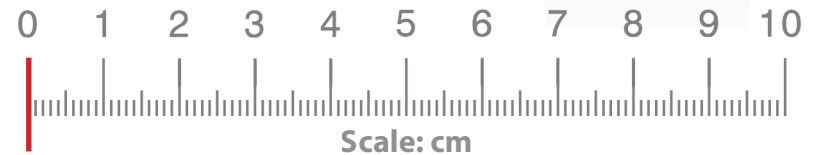

Type P

Ibanez

- AFJ 95
- AKJ 95
- AF 151
- AF 155
- ArtCore AK 85
- AS 93
- AS 153
- LGB30
- LGB300
- Signature Models

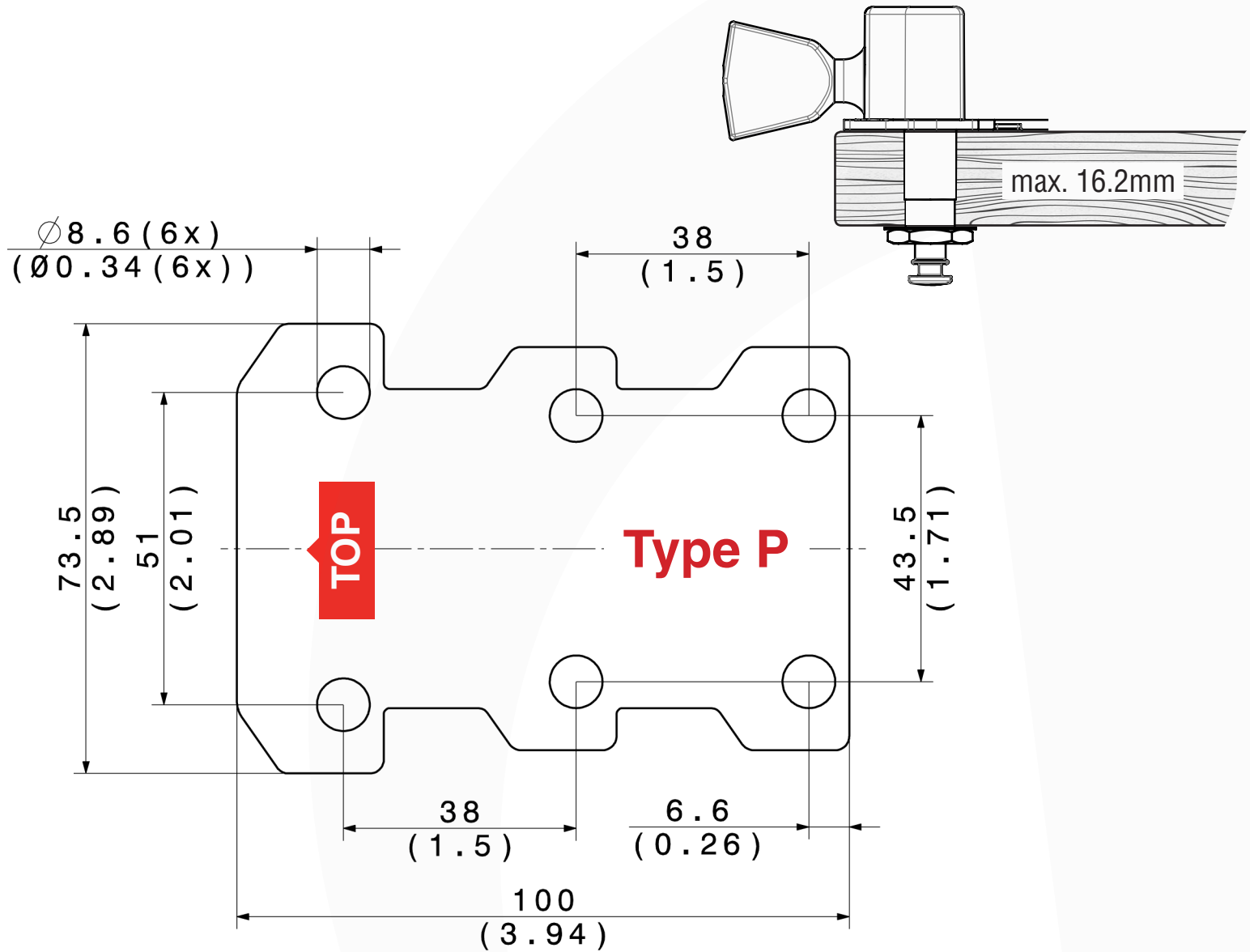

TYPE R

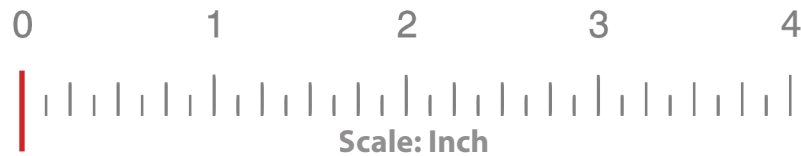
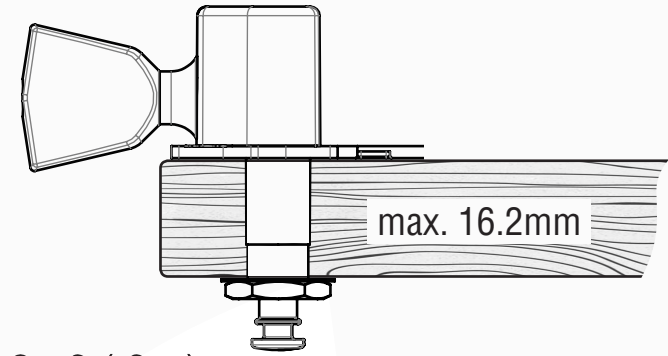
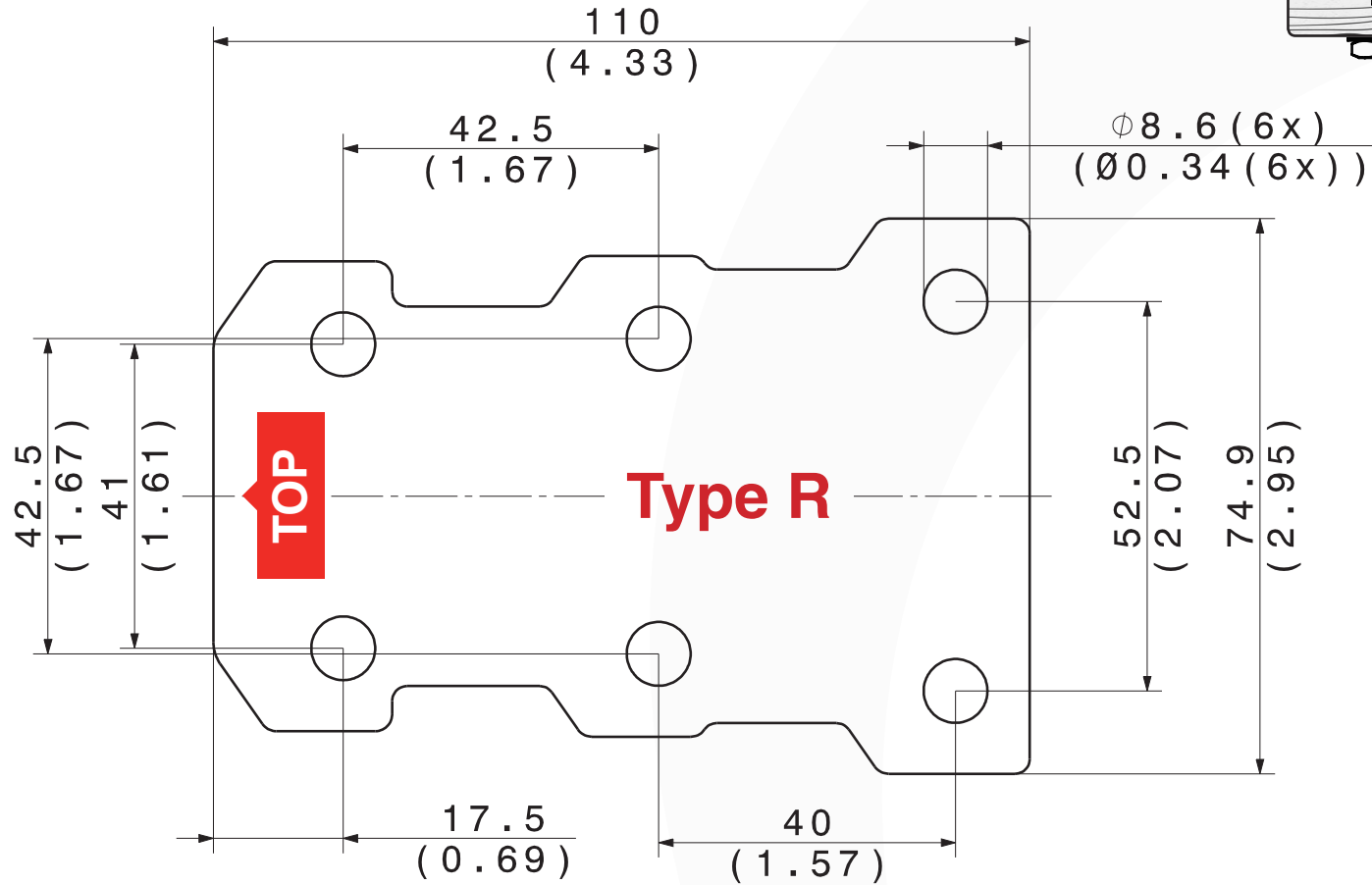

PLACE RULER HERE

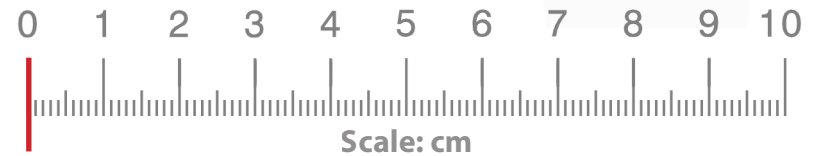

Type T1

Lakewood

Grand-Concert M-Serie

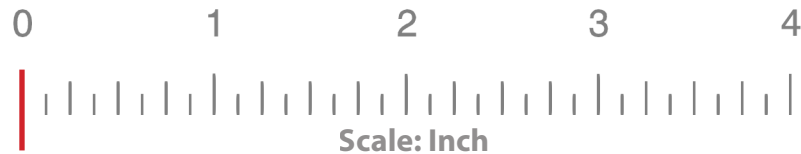
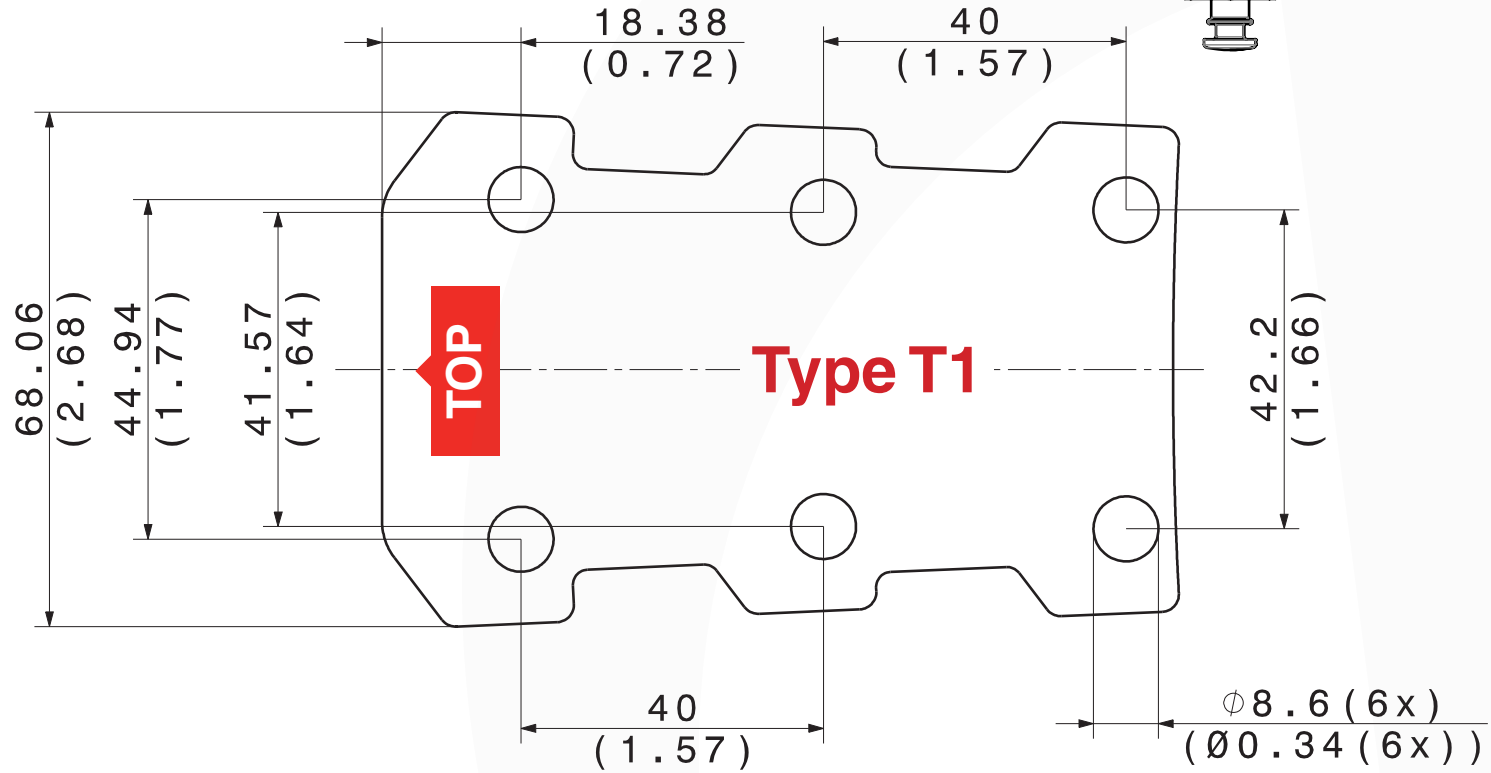
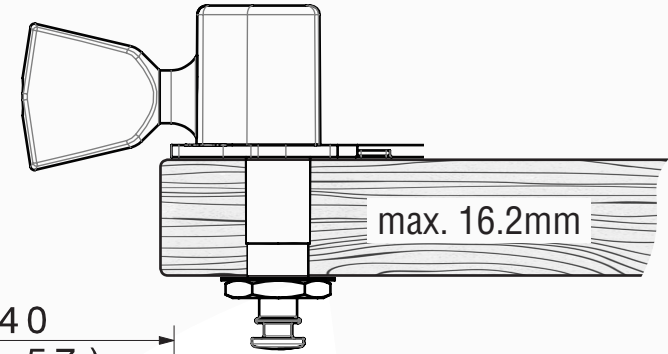

PLACE RULER HERE

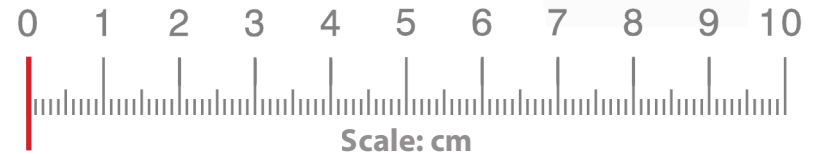

Type T

Düsenberg

Starplayer TV - Serie
Fullerton - Serie
CC - Serie

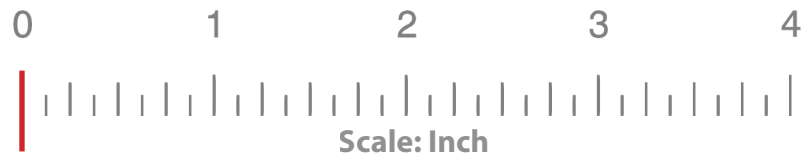
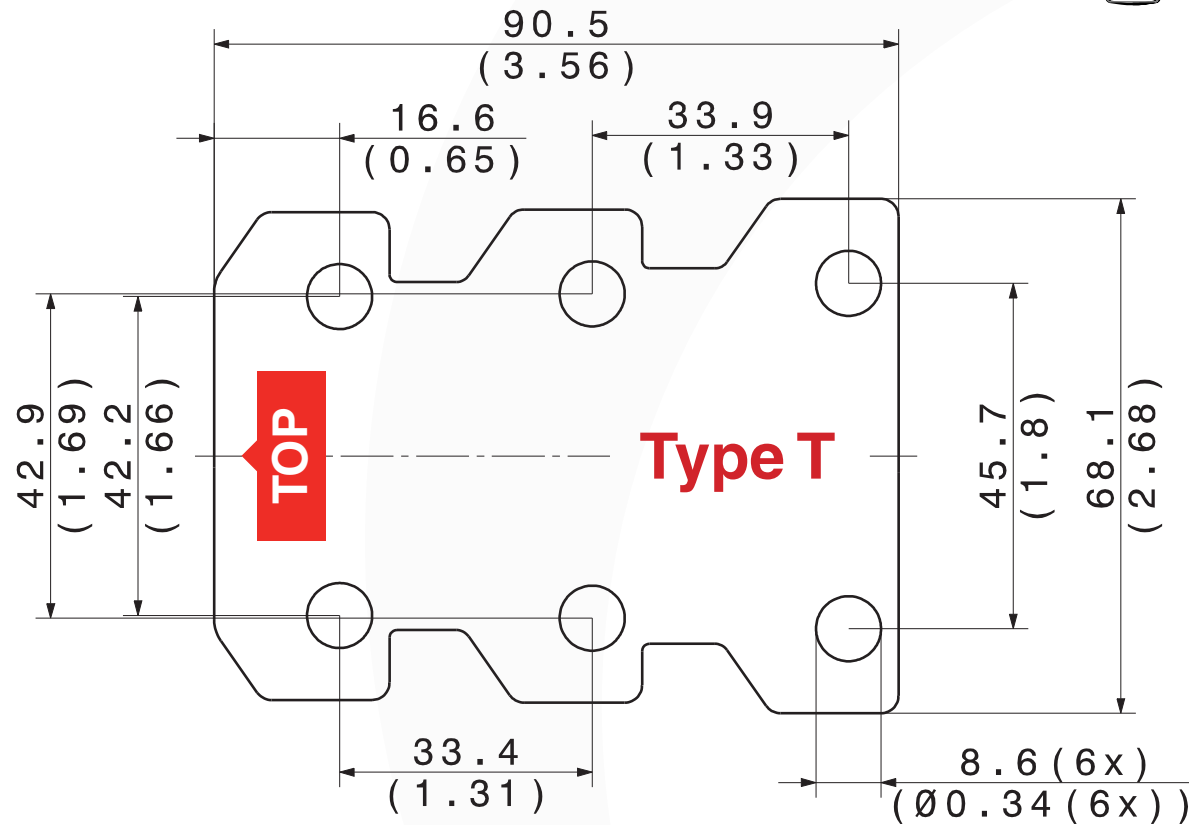
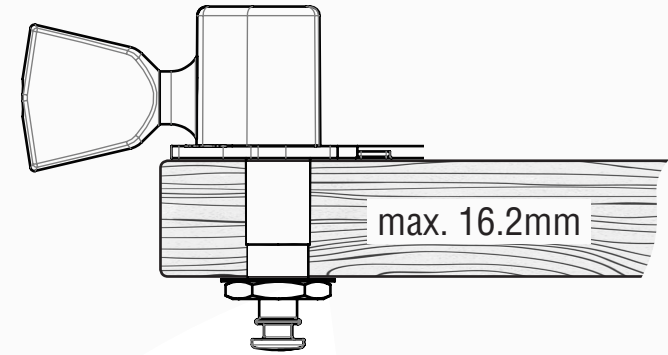

PLACE RULER HERE

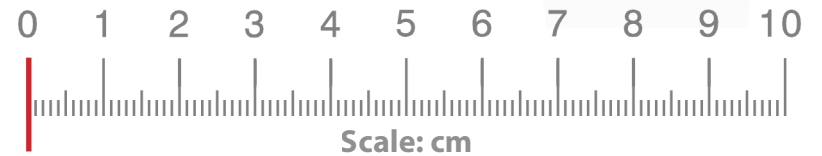

Type U

Larrivee

OM-3

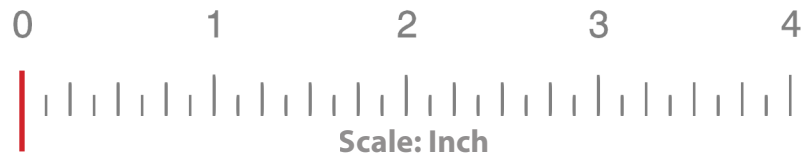
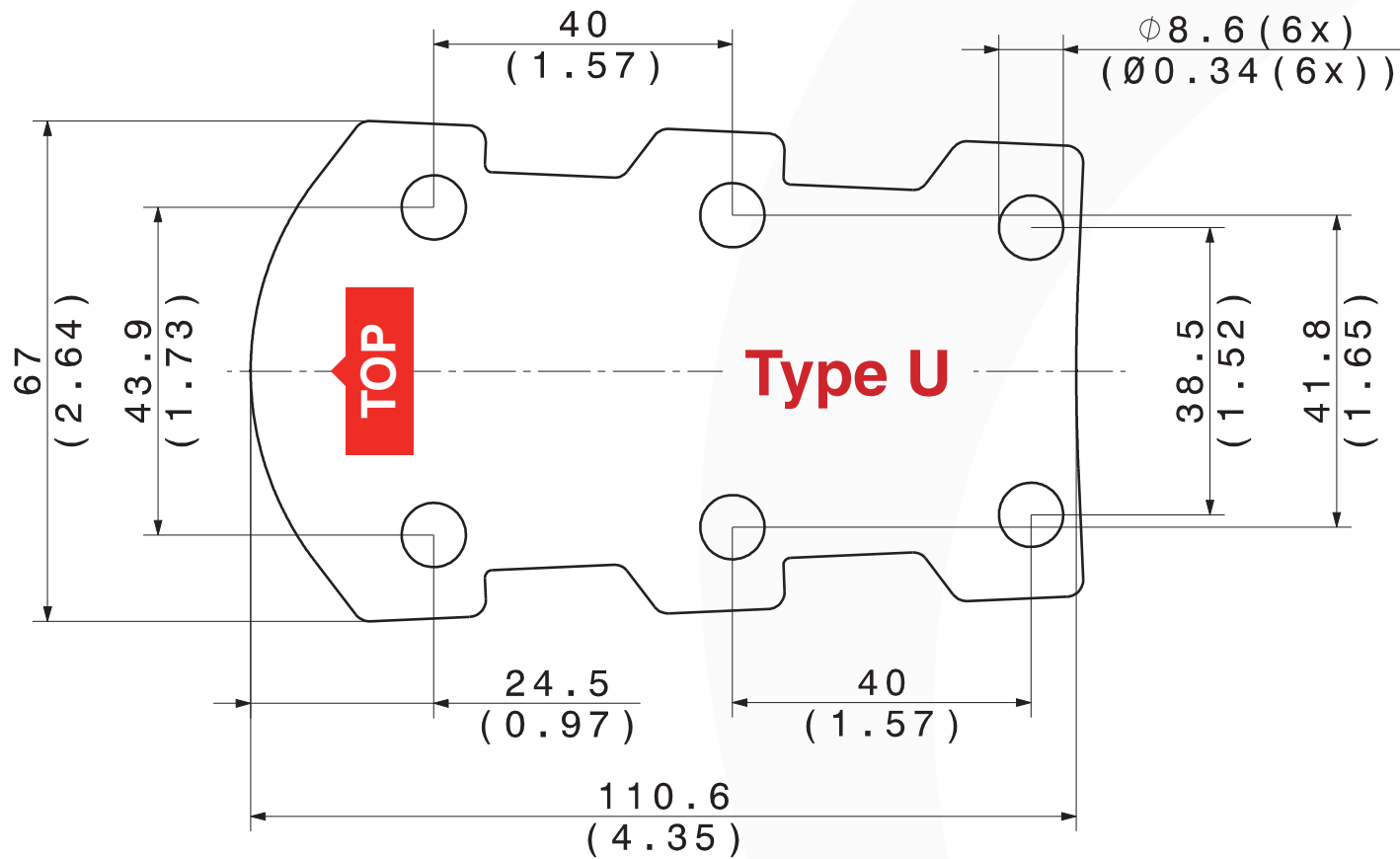
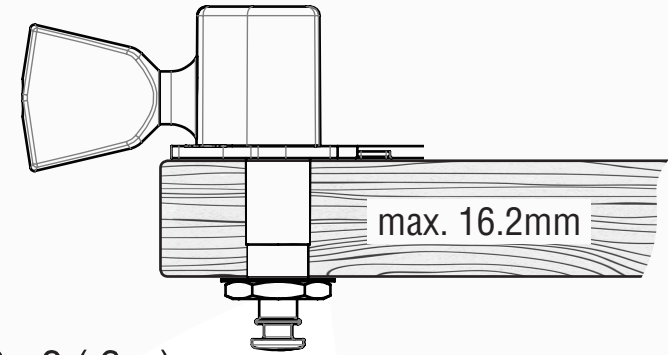

PLACE RULER HERE

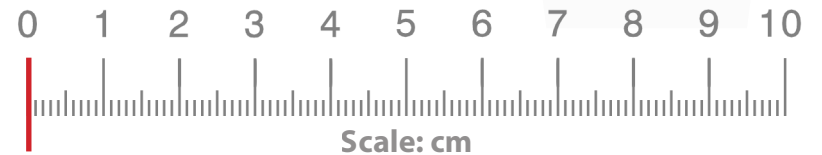

Type Y

BC Rich

Warlock Widow Headstock

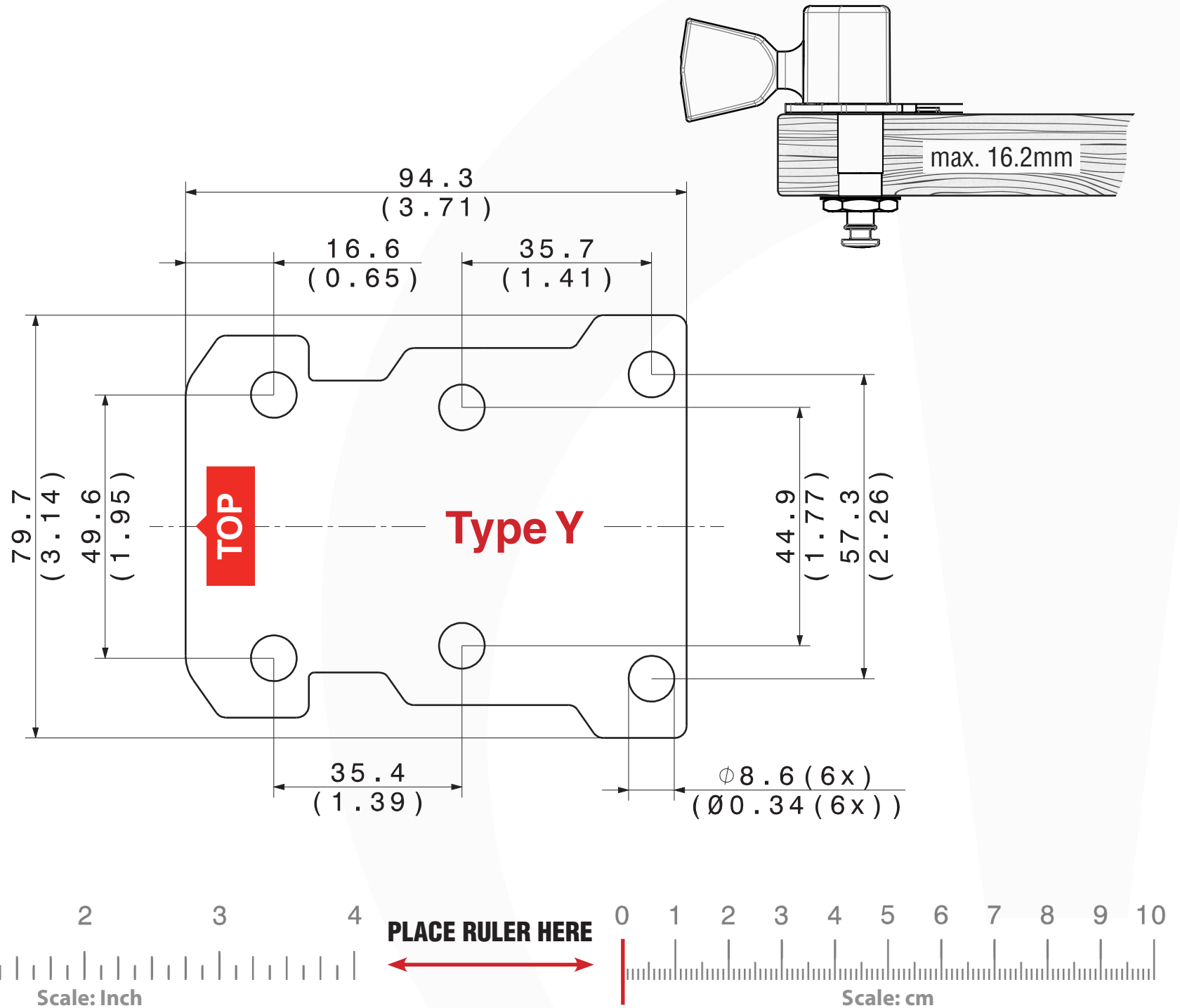

Type Z

Gretsch

G6122 1962 Country Gentleman classic

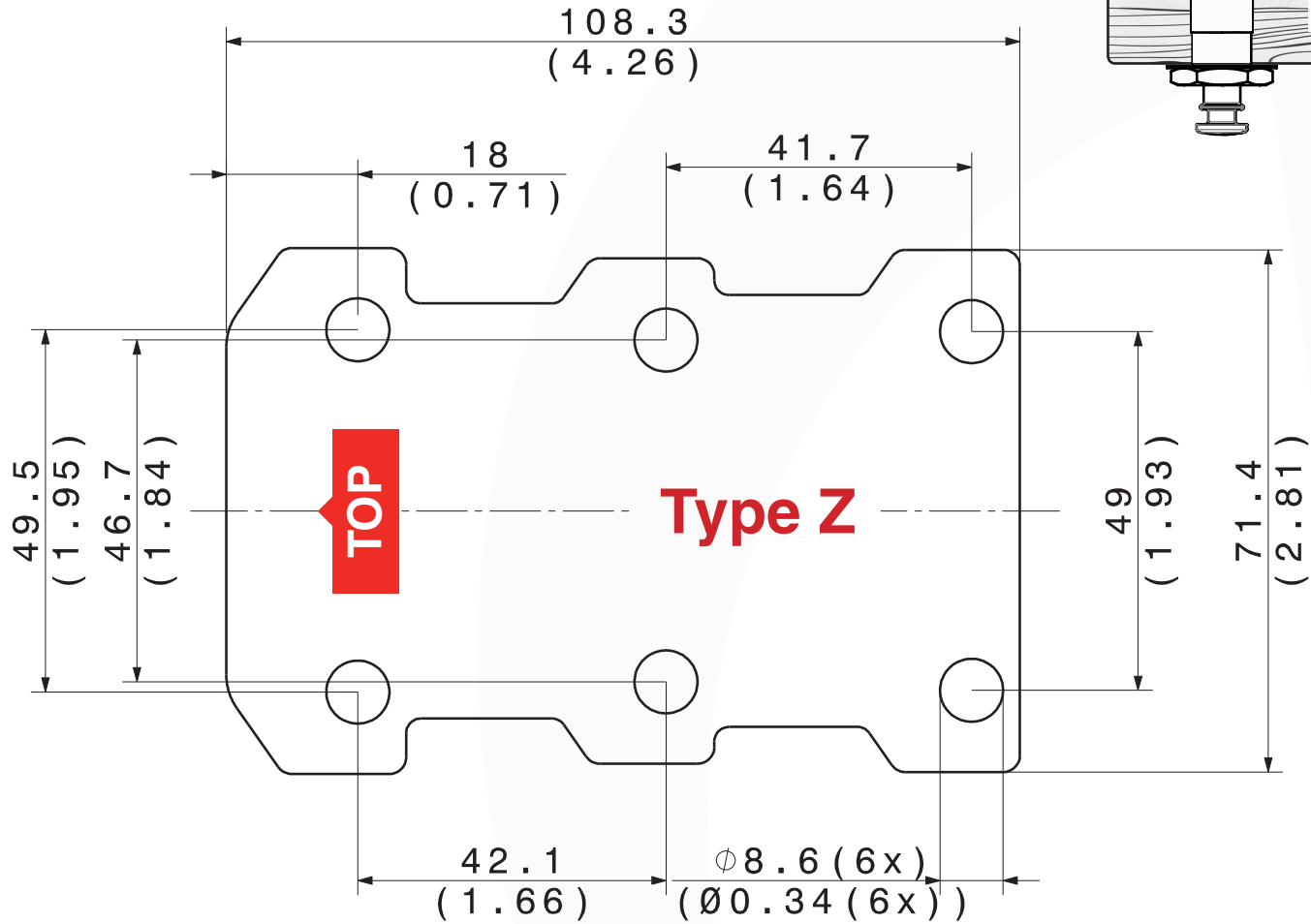

TRONICALTUNE PLUS

Template Types

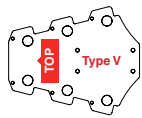

1. Printer Settings:

- Size Setting: 100%
- Page Adaption: None
- Page Scaling: None

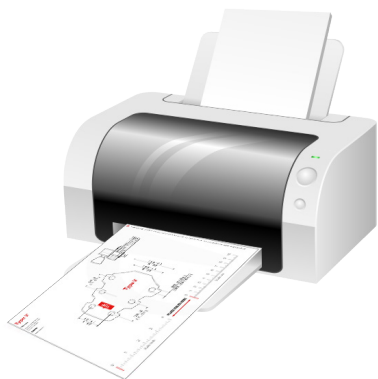

2. Place a ruler onto the printed templates to **check correct printout size**

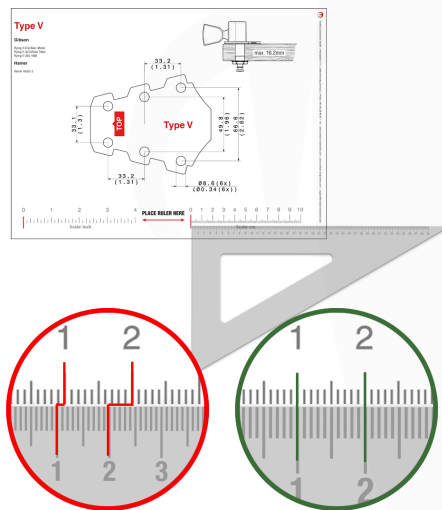

3. Cut-out the templates

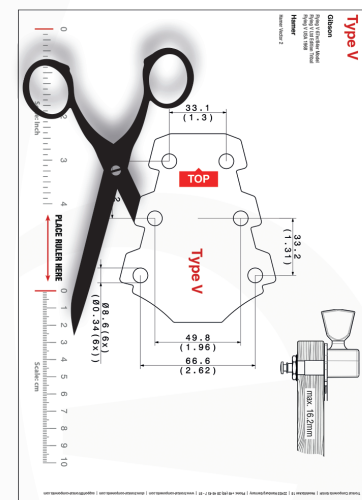

4. Place the templates **on the back** of your guitar headstock. Check if the holes of the template are congruent to the holes of your guitar. When they are congruent you identified the template that fits your guitar. Enter this type during the order process.

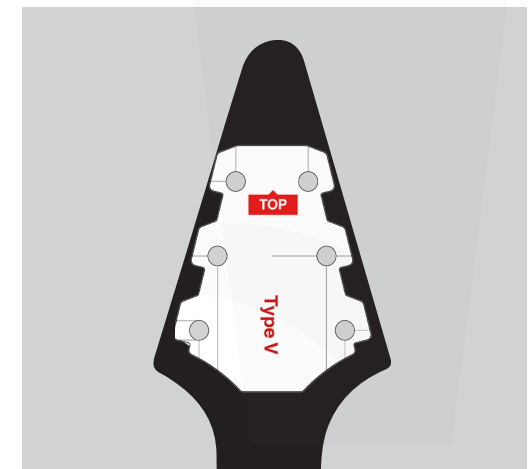

Type V

Gibson

Flying V 67er/84er Model
Flying V Ltd Edition Tribal
Flying V USA 1968

Hamer

Hamer Vector 2

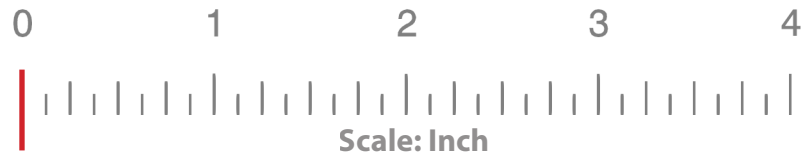
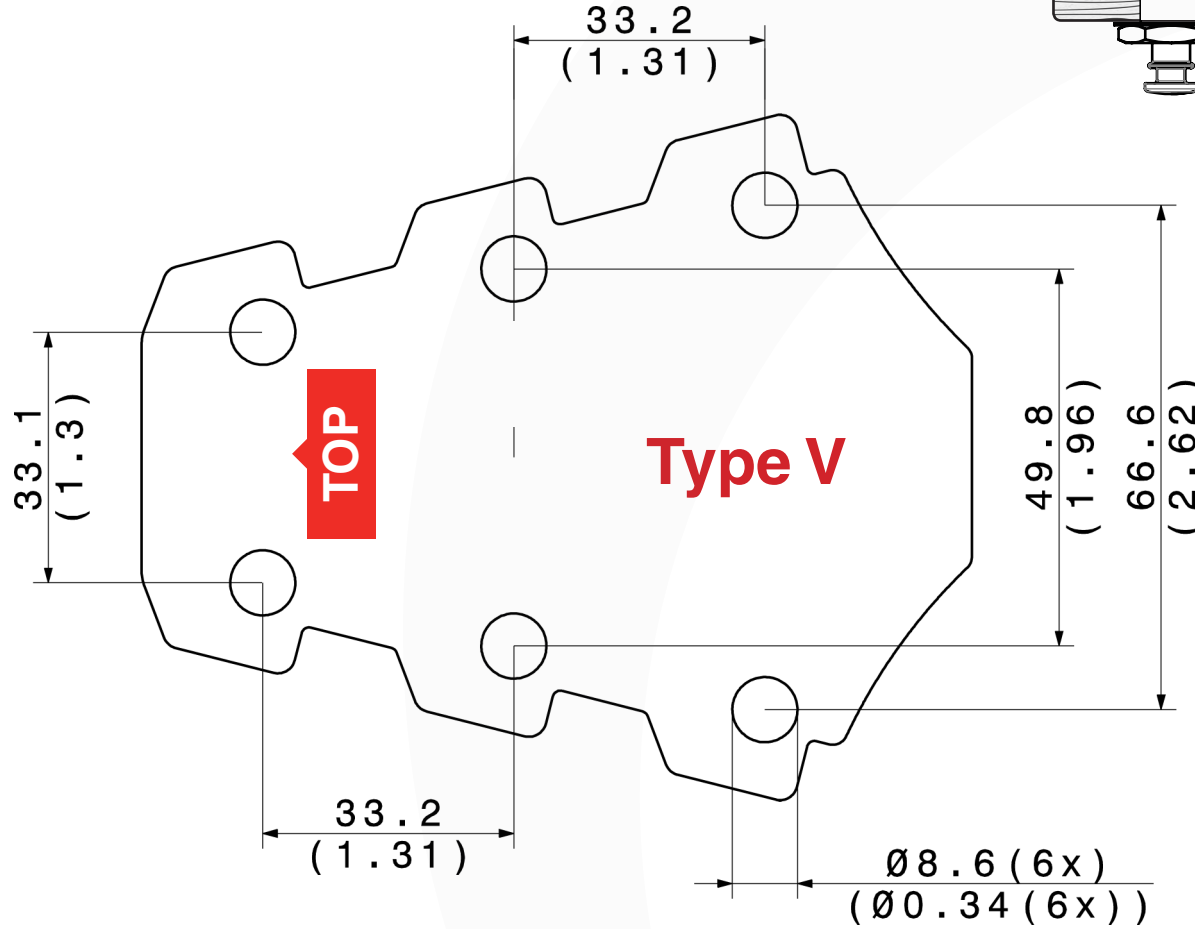
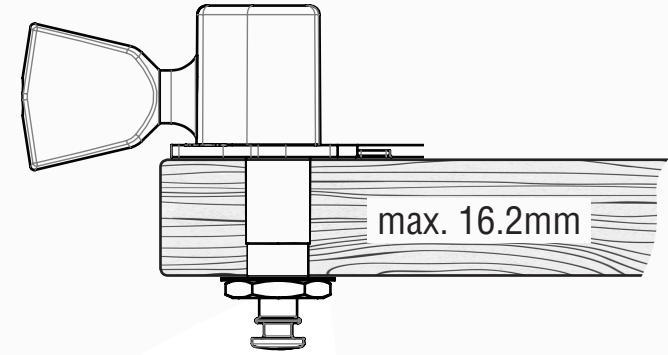

PLACE RULER HERE

