

SP-5500

User's Manual

STAGE PIANO

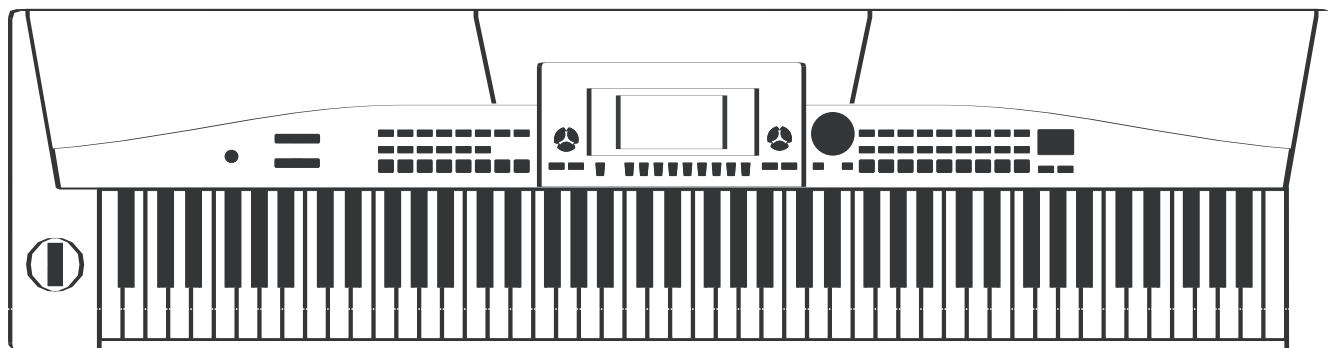

th•mann

Using the Instruction Manual

Congratulations on your purchase of this stage piano!

The piano is an user friendly piano with fabulous sound quality and advance feature such as style record and self-learning. No matter you are adult or children, you will enjoy playing the piano as it provides amazing styles for accompaniment, expressive tones, and real time record. Other features such as numbered musical notation display chord dictionary, variety of songs will help you better master the playing skill.

You are recommended to study this manual carefully before using the unit.

Precautions

Please read the following carefully before use:

- Do not expose the piano to high temperature, direct sunlight and excessive dusty places.
- Do not place the piano too close to other electrical appliances such as television and radio as. It may cause interference.
- Do not place the piano to excessive humid area. Avoid putting container with liquid on top of the piano in order to prevent damage of the internal parts of the piano by flowing liquid.
- Always unplug AC cord by gripping the plug firmly, but not pulling on the cable.
- Do not apply excessive force to the switches and buttons.
- When the piano is not in use or in the time of thunderstorm, please disconnect the power supply.
- Avoid adjusting the volume level to the maximum or to the levels that you feel uncomfortable, we recommend you to limit the volume level to two-third of the max for preventing the damage of auditory sense
- Unplug the power cable before cleaning the piano. Do not connect or disconnect the power cable with a wet hand.
- Check and clean the power plug periodically.
- To avoid damage to the piano and other devices to which it is connected, turn the power switches of all related device off prior to connecting or disconnecting cables.
- Clean the piano and remove the dust with a dry soft cloth or a slightly damp cloth.
- Never use cleaners such as thinner or alcohol. To prevent any damage on the surface of the LED display, please use lens cleaning tissue to clean the display.
- If the piano cable is damaged, please do not use the piano. Otherwise it may cause fire or electrical hazard.
- In case of malfunction due to improper handling the piano, please switch off and on again after 30 seconds.
- Do not attempt to disassemble or repair the piano. If the piano does not work properly, please contact the approved repairer.
- The piano should not be exposed to dripping or splashing.

Main Feature

- Keyboard: 88 hammer action key.
- Operation: use **DIAL** & **[+/YES]** & **[-/NO]** button or direct select button to select desired menu & parameters .
- Voice: 559 voices in total, 28 voices can be selected conveniently from the panel.
- Style: 203 styles in total, including 3 user styles, 16 voices can be selected conveniently from the panel.
- Song: 100 songs in total, each one has self-learning mode.
- Demo: 2 demos in total.
- Chord mode: fingered & full range.
- Song learning: three learning mode of lesson 1/2/3, left and right hand to choose, and offers the GRADE function.
- Chord dictionary: A function for you to learn the chords, including Direct 1 mode (dictionary mode) and Direct 2 (test mode).
- Record: 3 user songs, each one includes 1 accomp track & 5 melody tracks.
- Style record: 3 user styles, each one includes 8 paragraphs, each paragraph include 8 tracks.
- SD card: Portable storage device to save & load the user songs, user styles and memory datas.
- Memory: 48 memories in total (8 banks with 6 memories each).
- Style control: sync start, sync stop, start/stop, fill in a/normal, fill in b/variation, intro/ending, fade in/out, chord mode
- Function: tuning, beat, split point, pedal select, reverb level, chorus level, midi in, midi out.
- Mixer: Rhythm_s£rhythm_m£bass£chord 1£chord 2£chord 3£phrase 1£phrase 2£voice r1£voice r2£voice I£ SD play.
- Others: dual, split, dsp, piano, metronome, o.t.s., transpose +/-, accomp +/-, touch, pitch bend etc.
- Pedal: sustain pedal (immovable); Multifunctional pedal (soft£sostenuto£start/stop£memory select)
- Interface: midi in/out, usb, phone, line in/out
- Irradiance keys: style control£sync start£sync stop , fill in a/normal£fill in b/variation£intro/ending£fade£; style record£record£play/stop£accomp£melody 1£melody 5, style, voice, song;

Contents

• General Guide	5-6	• Memory	23
Front Panel.....	5	Bank.....	23
LCD Display.....	6	Memory Data.....	23
Rear Panel.....	6	Store and Load.....	23
Top Panel.....	6	• One Touch Setting	24
• Connections	7-8	• Record	24-26
Power Jack.....	7	Record Song.....	24-25
Setting Music Rest.....	7	Playback Song.....	25
Headphones Jack.....	7	Delete Song.....	26
AUX OUT Jack.....	7	• Style Record	27-32
AUX IN Jack.....	8	Start Style Record.....	27-28
Sustain Jack.....	8	Record a new Style.....	28-29
Soft Jack.....	8	Copy a Style.....	30
USB Jack.....	8	Quantify a Style.....	30-31
MIDI IN/OUT Jack.....	8	Edit a Style.....	31-32
• Preparation	9	Delete a Style.....	32
Power on key combination.....	9	• Song	33-35
Master volume control.....	9	Lesson Mode.....	33-34
Brilliance.....	9	Lesson 1.....	34
Demo.....	9	Lesson 2.....	34
• Voices and Effects	10-12	Lesson 3.....	35
Select a Voice.....	10	• Chord Dictionary	35-36
Dual Voice.....	10	• Pedal	37
Split Point.....	11	• SD Function	37-42
DSP Effect.....	11	Play.....	38
Pitch bend /Modulation joystick.....	11	Load.....	39
Touch Response.....	12	Save.....	40-41
Transpose.....	12	Delete.....	41
Piano.....	12	Format.....	41-42
• Style Control	13-19	• MIDI Function	43-44
Select a Style.....	13	What is MIDI.....	43
The Accompaniment Section.....	13	USB Connection.....	43
Start a Style.....	14	MIDI Connection.....	44
Fill A/B.....	15	MIDI Application.....	44
Stop a Style.....	15	• Specifications	45
Fade.....	16	• Trouble Shooting	45
Tempo.....	17	• Appendix	46-57
Accomp Volume.....	17	Appendix 1-Voice List.....	46-50
Metronome.....	17	Appendix 2-Style List.....	51-52
Recognizing Chords.....	18-19	Appendix 3-Song List.....	53-55
• Function Menu	20-22	Appendix 4-Demo List.....	55
Tune.....	20	Appendix 5-Chord List.....	56
Beat.....	20	Appendix 6-MIDI Implementation Chart.....	57
Split Point.....	21		
Pedal Assign.....	21		
Reverb Level.....	21		
Chorus Level.....	21		
MIDI Setting.....	22		
• Mixer Menu	22		

General Guide

Front Panel

- 1 BRILLIANCE sliding bar
- 2 VOLUME sliding bar
- 3 STYLE direct select button
- 4 TEMPO + / TEMPO - button
- 5 ACCOMP + / ACCOMP - button
- 6 TRANSPOSE + / TRANSPOSE - button
- 7 FINGERED LED
- 8 FULL RANGE LED

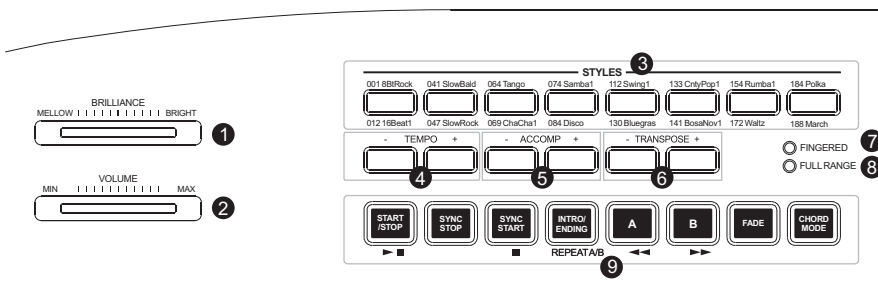

- | | |
|------------------|---------------|
| 9 Im Style-Modus | Im Song-Modus |
| -START/STOP | -START/STOP ▶ |
| -SYNC STOP | -PAUSE ■ |
| -SYNC START | -REPEAT A/B |
| -INTRO/ENDING | -REW ◀◀ |
| -FILL A | -FF ▶▶ |
| -FILL B | |
| -FADE | |
| -CHORD MODE | |

- 10 LCD Display
- 11 LEFT HAND button
- 12 RIGHT HAND button
- 13 CHORD DICTIONARY button
- 14 LESSON button
- 15 FUNCTION BACK button
- 16 FUNCTION NEXT button
- 17 MIXER button
- 18 BANK button
- 19 STORE M1-M6 button
- 20 ONE TOUCH SETTING (M1-M4)
- 21 O.T.S. button
- 22 STYLE button
- 23 VOICE button
- 24 SONG button
- 25 PIANO button
- 26 METRONOME button

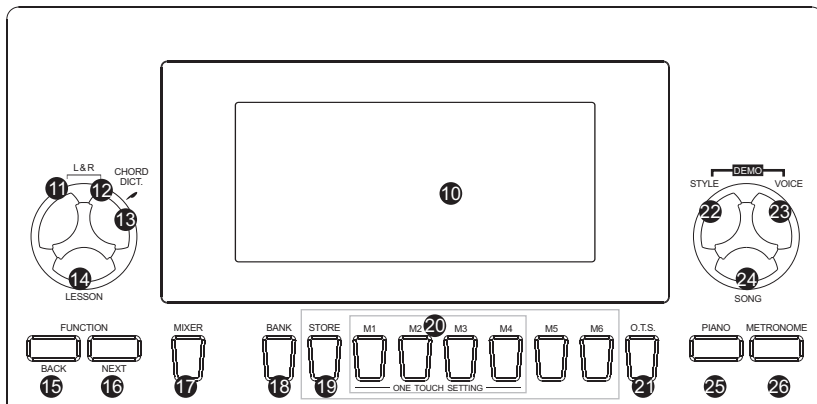

- 27 DATA DIAL
- 28 -/NO button
- 29 +/YES button
- 30 VOICE DIRECT SELECT button
- 31 STYLE RECORD button
- 32 SEQUENCER
- RECORD button
- PLAY / STOP button
- ACCOMP button
- MELODY 1 button
- MELODY 2 button
- MELODY 3 button
- MELODY 4 button
- MELODY 5 button

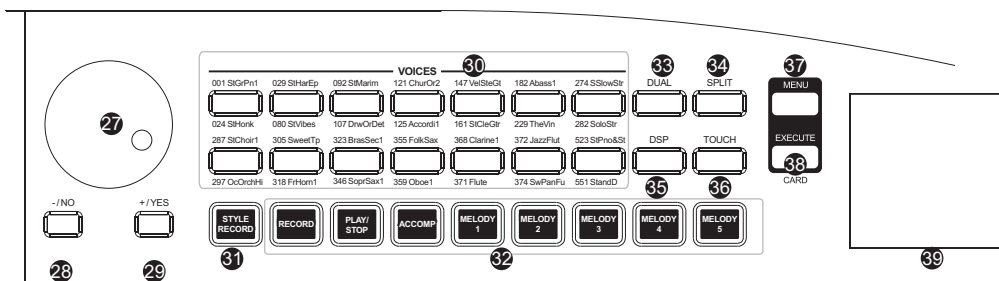

- 33 DUAL button
- 34 SPLIT button
- 35 DSP button
- 36 TOUCH button
- 37 SD MENU button
- 38 SD EXECUTE button
- 39 SD faucet

LCD Display

- 1 DUAL
- 2 SPLIT
- 3 TOUCH
- 4 DSP
- 5 VOICE/LR/STYLE/DEMO/SONG
- 6 RECORD / STYLE RECORD
- 7 MEASURE
- 8 BEAT
- 9 TEMPO
- 10 CHORD
- 11 MEMORY / ONE TOUCH SETTING
- 12 LEFT / RIGHT HAND LESSON MODE
- 13 NOTE Indication
- 14 FILL A / B
- 15 TREBLE CLEF
- 16 BASS CLEF

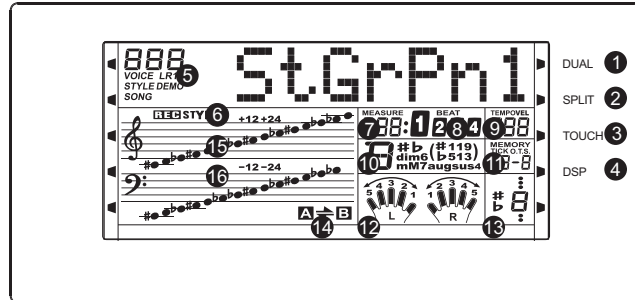

Rear Panel

- 1 POWER ON / OFF switch
- 2 POWER Jack
- 3 AUX OUT L/MONO jack
- 4 AUX OUT R jack
- 5 AUX IN jack
- 6 SUSTAIN PEDAL jack
- 7 ASSIGN PEDAL jack
- 8 MIDI IN jack
- 9 MIDI OUT jack
- 10 USB jack

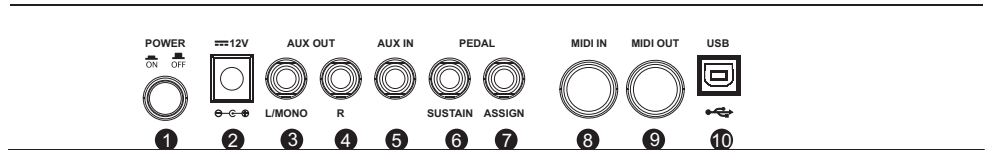

Top Panel

- 1 PITCH BEND / MODULATION joystick
- 2 PHONES 1 jack
- 3 PHONES 2 jack

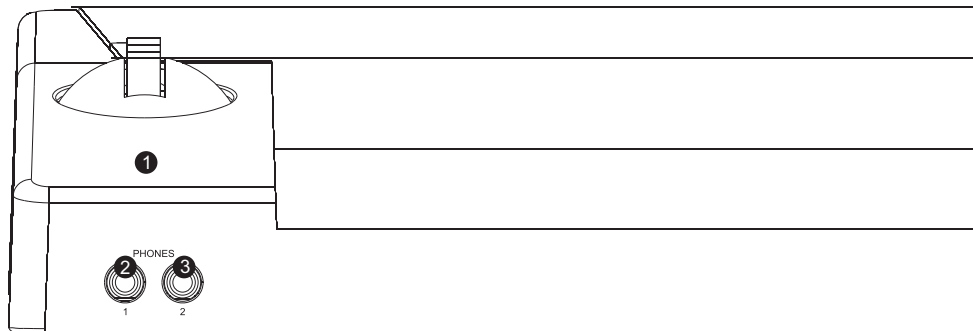

Connections

Power Jack

This piano can be powered by current from a standard household wall outlet by using the specified AC adaptor. The power jack is located on the rear panel of the piano body.

Make sure that only the AC adaptor specified for this piano is used.

The adaptor shall be 12V DC output, and center positive type. Make sure to turn off the piano before you connect the adaptor into the AC wall outlet and the cord into the unit.

Cautions£

Use of another type of adaptor creates a danger of fire and electrical shock. For safety sake, make sure to unplug the AC adaptor from the wall outlet whenever leaving the piano unattended for a long time or during a thunderstorm.

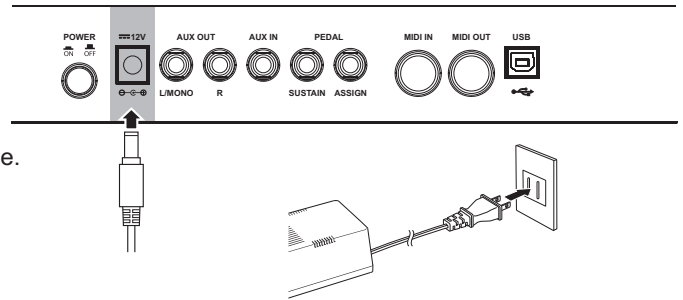

Setting Music Rest

The piano is supplied with a music rest that can be attached to the instrument by inserting it into slot at the rear of the control panel.

Please set up the music rest as shown:

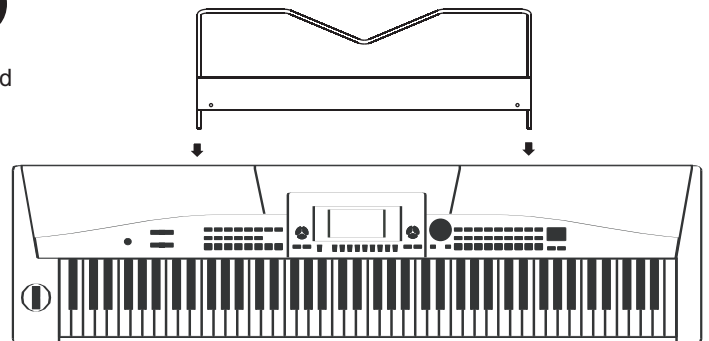

Headphones Jack

There are two phones jacks, speaker is shut off when headphone is plugged into one of the phones jacks, the other one is speaker sound is always on when headphone is plugged. Speaker is shut off when a pair of headphones connected to the two jacks.

Cautions!

Never use the headphone with high volume, as it may hurt your ear.

To prevent the damage of the speakers, ensure that the volume is set to the minimum level before connecting the power and other devices.

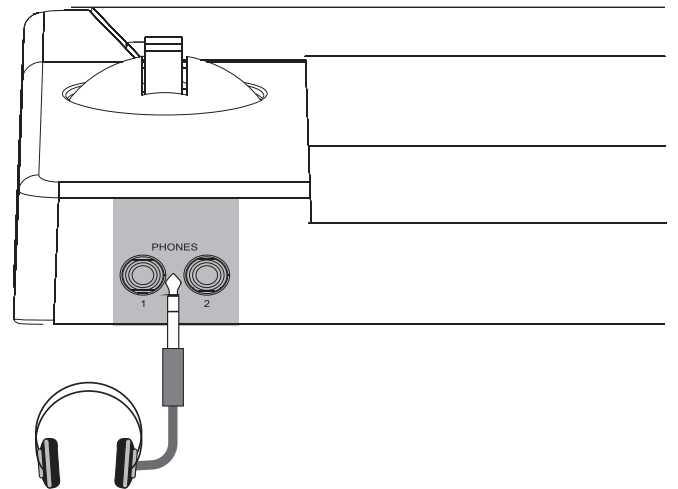

AUX OUT Jack

When you want to listen to the voice with an amplifier, connect amplifiers to the AUX OUT L/MONO and R jacks on the rear panel. The volume is adjusted with the VOLUME button. (For monaural playback, use the L/MONO jack. For stereo playback, connect both L/MONO and R jacks.)

Cautions!

To avoid damaging the speakers, please ensure that volume has set to the minimum level before connecting the power and other devices.

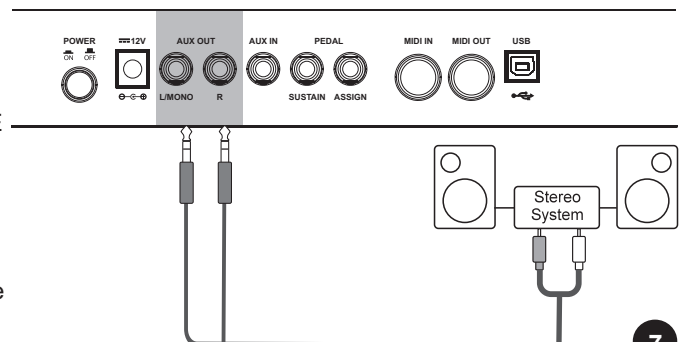

AUX IN Jack

The audio output from a CD player connected to the AUX IN jack on the left panel can be mixed with the sound of the piano module. This function is convenient when you want to play along with a favourite song. The volume of the external signal is adjusted with the VOLUME button.

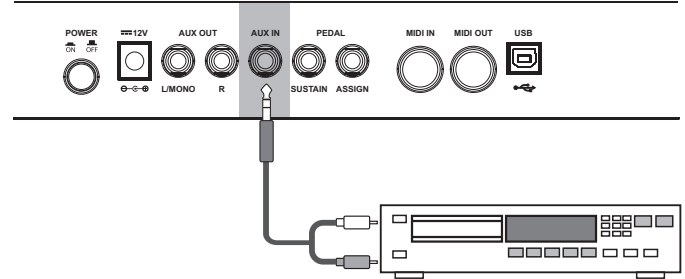

Sustain Jack

Step on the footswitch, all notes played on the keyboard have a longer sustain effect.

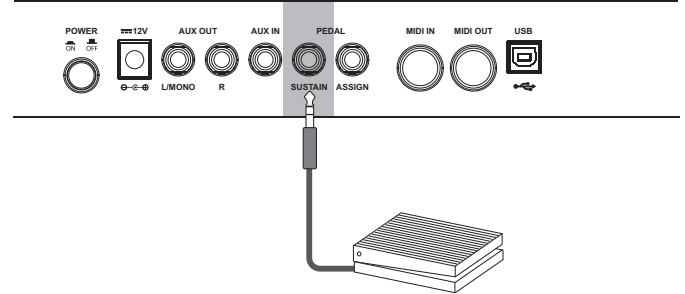

Assign Jack

An optional footswitch can be plugged into the ASSIGN jack for soft pedal, sostenuto pedal, memory select, style start/stop control.

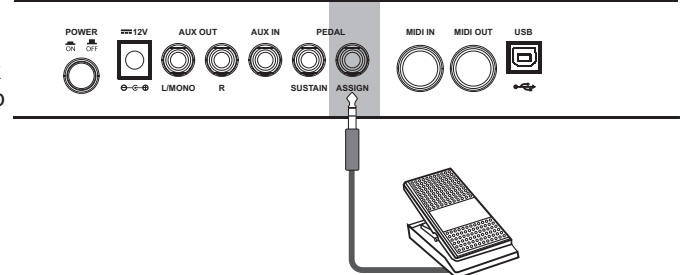

USB Jack

Connect PC or other USB host devices that support USB Audio.

You can simply connect the MIDI/USB converter to your USB play on your computer and plug the MIDI in and out cables into the piano, after the driver is installed and initialization is finished, you can choose USB Audio Device in the device menu of the software to transfer midi data.

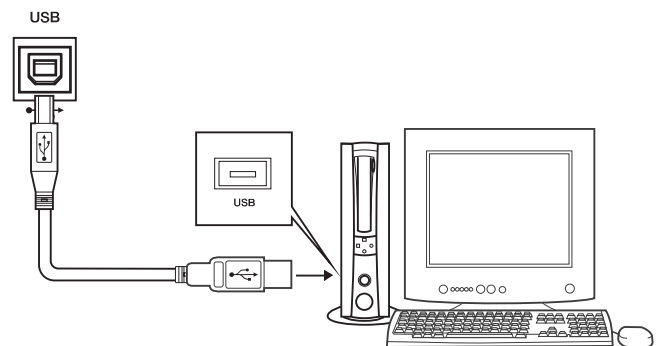

MIDI IN/OUT Jack

MIDI stand for Musical Instrument Digital Interface.

MIDI is a world wide standard that makes it possible for various electronic musical instruments and other devices.

MIDI IN:

Data transmitted from other MIDI instrument via MIDI is received by this terminal.

MIDI OUT:

Data produced by the Digital Piano is transmitted to other MIDI instruments via MIDI from this terminal.

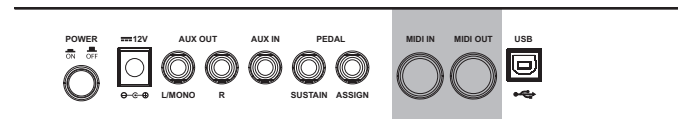

WARNING

To avoid damages, please be sure to turn off the power switches before you disconnect the related devices from the piano.

Preparation

Power on key combination

- 1 Press the **[RECORD]** & the **[PLAY/STOP]** button synchronously when it is power on. It can clear the record data.

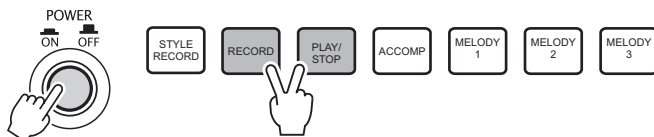

- 2 Press the **[STORE]** & the **[M1]** button synchronously when it is power on. It can set all the memory data to default value.

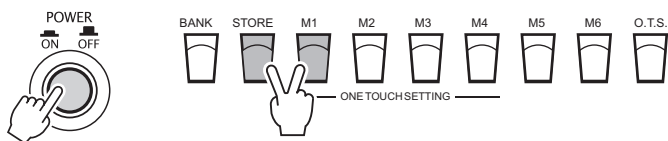

- 3 Press the **[+/YES]** & the **[-/NO]** button synchronously when it is power on, it can reset all the setting to the default value. (Including Memory data, Record data, Style Record data.)

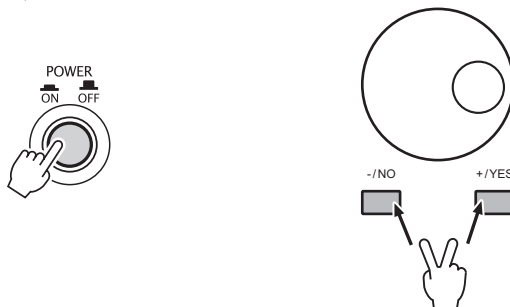

Master volume control

Push the **[VOLUME]** handspike rightwards, the volume increases.

Push it leftwards, the volume decreases.

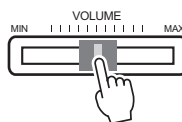

Brilliance

To create brighter sound, push **[BRILLIANCE]** handspike to the right.

To create gloomy sound, push **[BRILLIANCE]** handspike to the left.

You can change the piano brilliance as your wish.

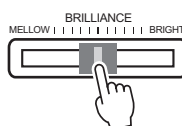

Demo

There are total of 2 Demos.

- 1 Press the **[STYLE]** & the **[VOICE]** button synchronously to enter the demo mode, the DEMO flag on LCD is lightened. It displays the first demo and plays all demos circularly.

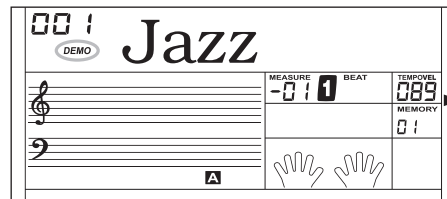

- 2 Press the **[STYLE]** & the **[VOICE]** button again or press the **[START/STOP]** button to stop playing and quit current mode.

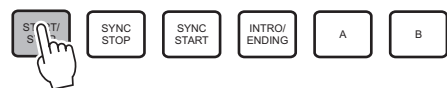

- 3 When playing, press the **[+/YES]** & the **[-/NO]** button or rotate the **DIAL** to select the song you want.

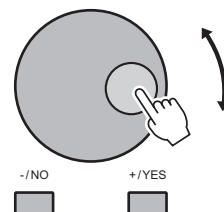

Voices and Effects

Voice select

559 voices in total.

- 28 voices can be directly selected. Each direct select button includes 2 different voices, the first press to select upper one, the second to lower one. The default is upper voice when it is power on.

VOICES								
001 StGrPn1	029 StHarEp	092 StMarim	121 ChurOr2	147 VelSteGt	182 Abass1	274 SSlowStr		
024 StHonk	080 StVibes	107 DrwOrDet	125 Accordi1	161 StCleGtr	229 TheVin	282 SoloStr		
287 StChoir1	305 SweetTp	323 BrasSec1	355 FolkSax	368 Clarine1	372 JazzFlut	523 StPno&St		
297 OcOrchHi	318 FrHorn1	346 SoprSax1	359 Oboe1	371 Flute	374 SwPanFu	551 StandD		

- When it is power on, LCD lightens the "VOICE R1" flag and displays the 001 voice name.

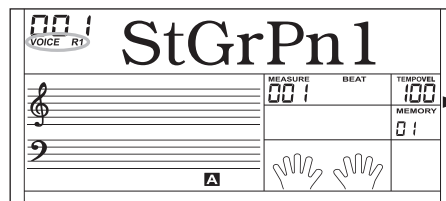

- Press the voice direct select button, or use the [+ / YES], [- / NO] button and DIAL to select the others.

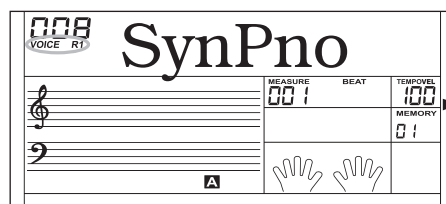
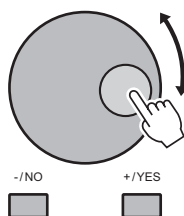

NOTE

- When the state changes to the VOICE by pressing the [VOICE] button for the first time, LCD displays the VOICE R1 state. Press it again and later, LCD will switch and display the other voice modes being opened in turn, the order is: VOICE R1->VOICE R2->VOICE L->VOICE R1.

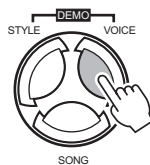

Dual voice

You can play two sounds at the same time on the piano in Dual Voice mode.

When the dual function is off, the voice indicated is VOICE R1. When the dual function is on, the voice indicated is VOICE R2.

- During the VOICE R1 status, press [DUAL] button to enter the dual voice mode. "VOICE R2" and "DUAL" signal would be lightened simultaneously. The number of the dual voice will be displayed on the LCD. Now, you can get two different sounds at the same time when pressing one key.

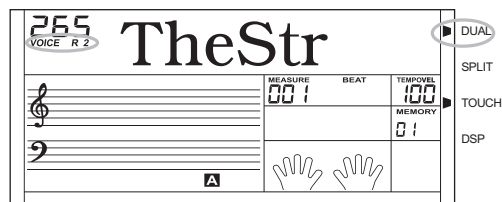
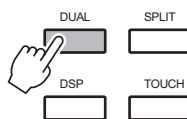

- Press [+ / YES] / [- / NO] button, or rotate the DIAL to select your desired voice. The default DUAL VOICE number is "No:265 The Strings".

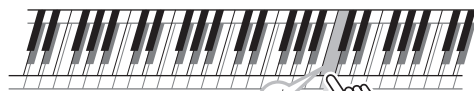

Eg. Piano
Eg. Cello
Two voices will sound at the same time.

- Press [DUAL] button again to turn off the DUAL VOICE. Voice R2 will be disabled, the note you play sounds a single voice of Voice R1.

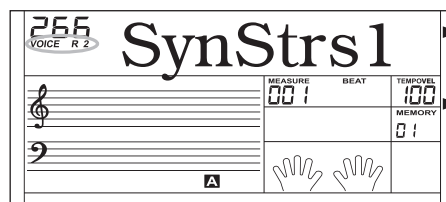
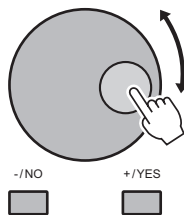

NOTE

- While the keyboard is splitted, only the right hand area will respond to the dual voice, the left hand area produces sounds in chords.

Split point

You can play two sounds on different parts of the keyboard. It is called Split mode.

- 1 Press **[SPLIT]** button to turn on the LOWER VOICE, LCD lights the SPLIT flag and displays "VOICE L" and its name. When you play in real time, you can activate Split Mode simply by pressing this button.
- 2 Press **[+/YES]** / **[-/NO]** button, or turn the DIAL to select the voice you want. The default LOWER VOICE number is "No 265 The Strings".
- 3 Press **[SPLIT]** button again to turn off the LOWER VOICE. LCD darkens its flag.

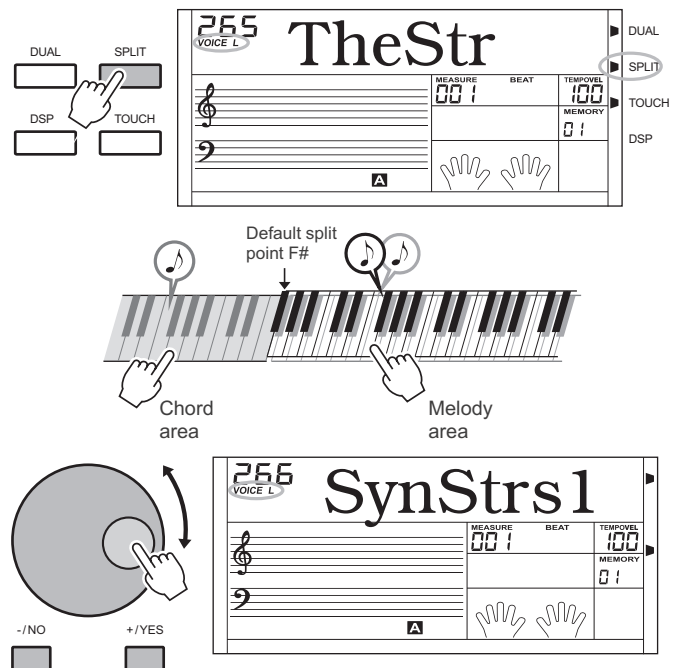

DSP Effect

DSP effect will enhance the piano with fuller and expressive sound.

- 1 When power is on, LCD lightens the DSP flag. Press the **[DSP]** button to switch the DSP setting. 4 DSP settings are available for selection, DSP 1/2/3/off, the default setting is 2. The DSP effect will be closed after being set to OFF, the DSP flag goes out.
- 2 You can change the current setting by pressing the **[DSP]** button continuously, and by adjusting the REVERB and CHORUS level to change the current effect. (See Function menu for detail)

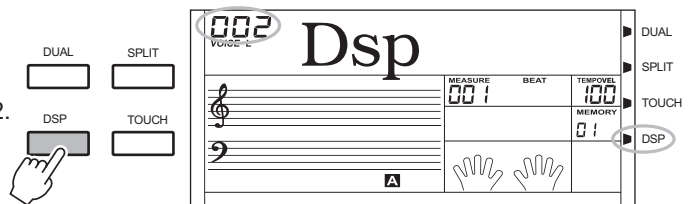

Pitch bend/Modulation joystick

- 1 Turn the joystick left and right to activate the PITCH BEND effect, it would adjust the tune of melody, turn left to increase pitch, turn right to decrease pitch, ranging between +/- 2 semitones.
- 2 Turn the joystick up and down to activate the MODULATION effect. Turn up or down to increase the effect, release the joystick to turn off the effect.

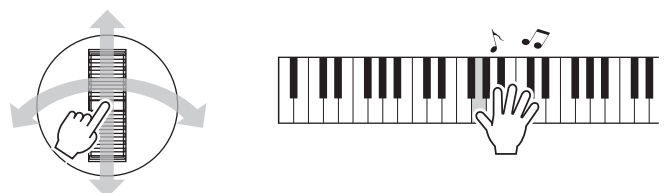

Touch Response

This function allows you to activate the dynamic level when playing the keyboard.

- 1 Press the **[TOUCH]** button, LCD lightens the "TOUCH" flag and displays touch response type "002 Touch" briefly.
- 2 4 setting are available for selection, TOUCH 001/002/003/OFF, the default is 002. You can change the current setting by pressing the **[TOUCH]** button.
- 3 If the type is set as "OFF", the "TOUCH" flag goes out, there is no touch response to piano.

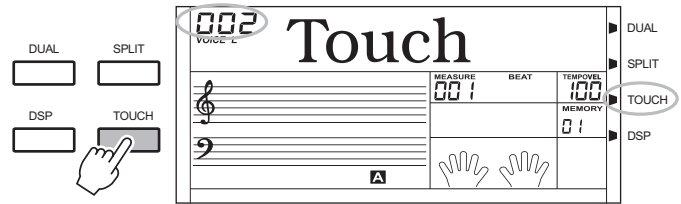

Transpose

You can shift the pitch of the entire keyboard with the TRANSPOSE function by adjusting the pitch in semitone steps.

- 1 Press the **[TRANSPOSE +]** or **[TRANSPOSE -]** button for the first time to enter the Transpose setting mode, LCD displays current transpose value briefly.
- 2 Press them again and later, the value will increase or decrease by degrees, also you can use the **[+YES]** and **[-NO]** button or the **DIAL** to adjust it, ranging from -12 to +12 semitones, the default value is 000.
- 3 In TRANSPOSE setting, pressing the **[TRANSPOSE +]** and **[TRANSPOSE -]** button simultaneously will set the value to default.

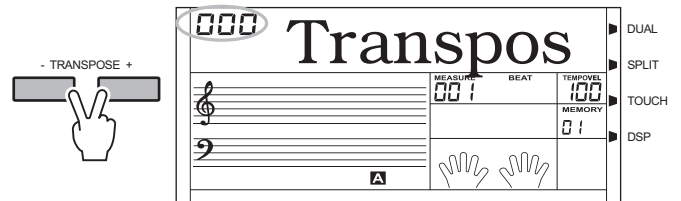
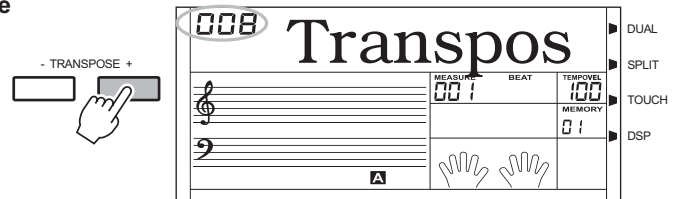

NOTE

- If you don't press any button for 5 seconds after entering the transpose setting mode, it will quit this menu automatically.

Piano

- 1 Press the **[PIANO]** button to enter the PIANO mode, the chord mode will be disabled automatically, the full range on the keyboard is piano voice.
- 2 Press the **[PIANO]** button again to exit the current mode. Press the **[VOICE] + [STYLE]**, **[SONG]**, **[VOICE]** and the direct select button, or the **[DUAL]**, **[SPLIT]**, **[M1]~[M6]** button, you can exit the piano mode.
- 3 You can select and play the style by pressing the **[STYLE]** and the direct select button, LCD will then display the style name. Accompaniment control will respond in effect as usual only with the drum tracks.

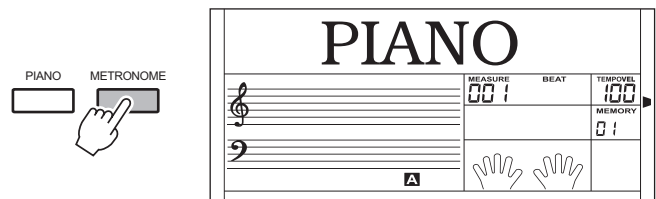

Style Control

The keyboard has a total of 203 styles, from 001 to 203, including 3 user styles. The default style is 001. (See appendix: page 60)

Select a Style

- 1 Press [STYLE] button to set the keyboard to the "style mode". The "STYLE " flag and the style number will show up on the display.

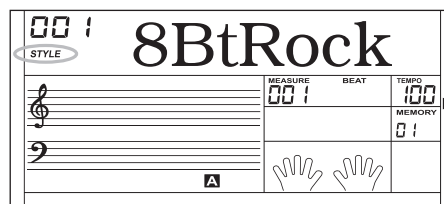
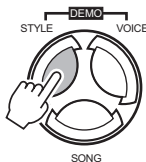

- 2 Press [+ /YES] / [- /NO] button or use DIAL to select the style you want.

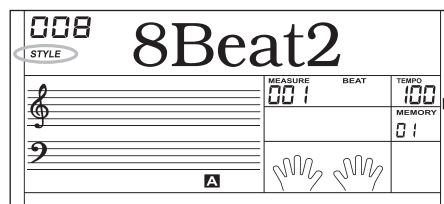
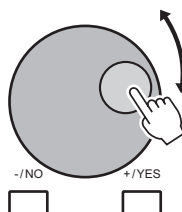

- 3 Direct Select Button

Use the Direct Select Button to select your desired style (16 styles), 2 direct styles for each button (upper & nether).

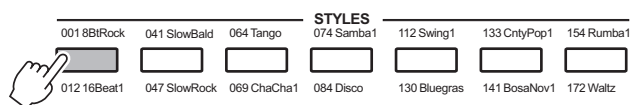

NOTE

- While changing a style, pay attention to the rules:
If the same button has been pressed twice, the style will be swapped from one to another.
- When the upper/nether style is on, and you then press another direct button, the corresponding upper/nether style will be selected.

The Accompaniment Section

Accompaniment consists of Intro, normal, variation, fill (a-a, a-b, b-a, b-b), ending. Using different sections based on the structure of styles enables you to enhance musical performance.

- 1 INTRO

Press the [INTRO/END] button to insert an intro section before playing. The rhythm will begin with a 2-4 measure introduction which will be followed by a main section.

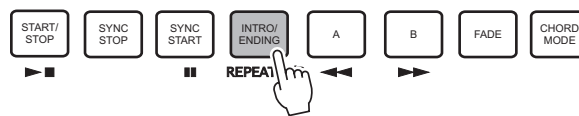

- 2 NORMAL and VARIATION

There are two main sections: normal and variation. Each section consists of 2 to 4 measures.

- 3 FILL

While the accompaniment is playing, you can fill in the rhythm/accompaniment by pressing the [FILL A] button or the [FILL B] button. This will automatically insert a fill section.

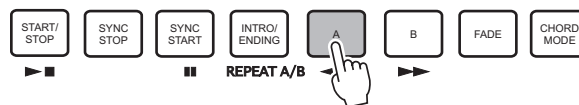

- 4 ENDING

When you press the [INTRO/END] button, in process of accompaniment playing, it brings the ending section appropriate for the accompaniment, and then stop the performance.

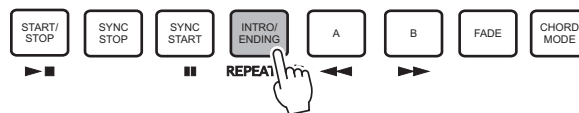

Start a Style

1 Start immediately:

Use **[START/STOP]** button to start the style.

2 Chord. Mode:

Press the **[CHORD MODE]** button for the first time to enter the FINGERED mode, the relevant LED is lightened.

The left area of keyboard are known as the chord area, when playing the chord, both the bass and the chord voice phonate.

Press the **[CHORD MODE]** button for the second time to enter the FULL RANGE mode, the relevant LED is lightened.

The whole keyboard are known as the chord area, but only to detect the chord and make the current voice of keyboard while style playing.

Press the **[CHORD MODE]** button for the third time to close the chord mode.

There are 2 ways to detect the chord: single finger detect and fingers detect. If the chord playing accord with fingers detect, it is recognized as the fingers chord. If not, single finger chord will be recognized.

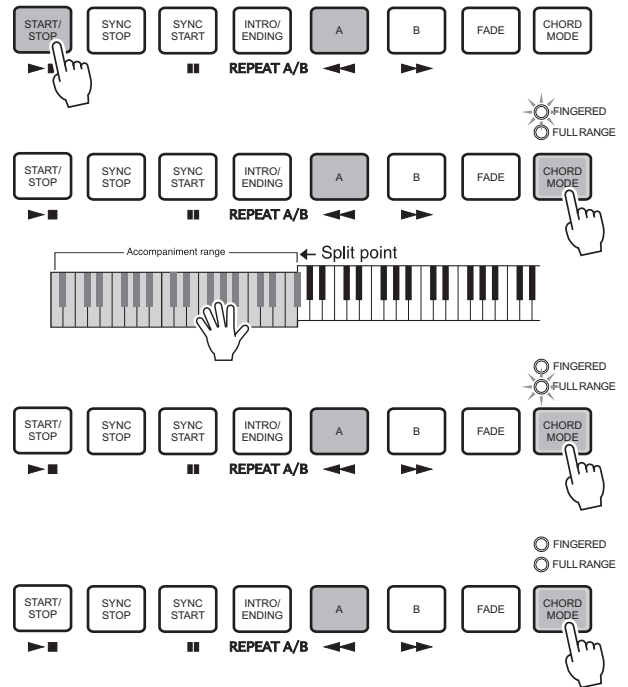

3 Sync Start:

Press the **[SYNC START]** button, The SYNC START LED lightens, LCD flashes 4 beats with current tempo. Press the **[INTRO/ENDING]** button to insert INTRO. In this mode, playing the keyboard will start the style automatically.

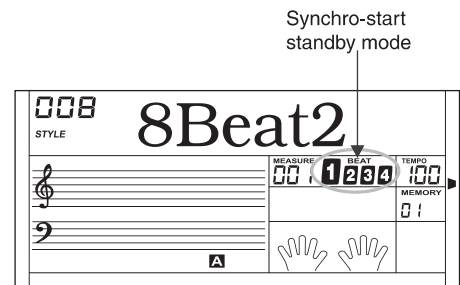
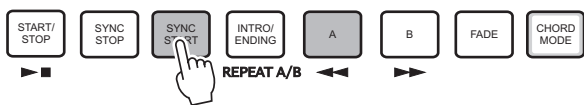

NOTE

- If chord mode is off, play any key on keyboard to start the style.
- If chord mode is on, only play the chord area key to start the style with the Auto Bass Chord accompaniment.

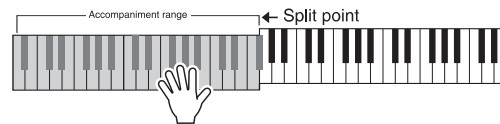

4 Intro Start:

When style is not playing, press the **[INTRO/ENDING]** button, "A" or "B" flashes on LCD, indicates the intro section is ready to play. Length of intro varies in different style.

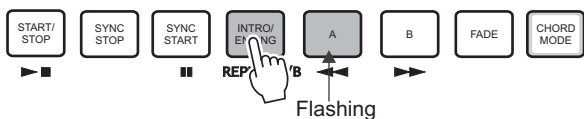

Press **[START/STOP]** button, then the style starts with an intro section, followed by the main section.

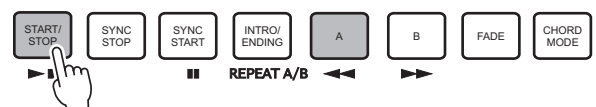

Fill A/B

- 1 In NORMAL mode, press **[A]** button to insert 1 measure fill and LCD flashes 'A'. After one measure is over, NORMAL style will be returned.
- 2 In NORMAL mode, press **[B]** button to insert 1 measure fill and LCD flashes 'B'. After one measure is over, VARIATION mode will be started.
- 3 In VARIATION mode, press **[B]** button to insert 1 measure fill and LCD flashes 'B'. After one measure is over, VARIATION style will be returned.
- 4 In VARIATION mode, press **[A]** button to insert 1 measure fill and LCD flashes 'A'. After one measure is over, NORMAL style will be started.

NOTE

- Hold down the **[A]** / **[B]** button when the style is playing, the selected FILL pattern repeats continuously until button is released.
- Press **[A]** when style stop, it will change to the normal section, the flag "A" on LCD will be lightened;
- Press **[B]** when style stop, it will change to the variation section, the flag "B" on LCD will be lightened.

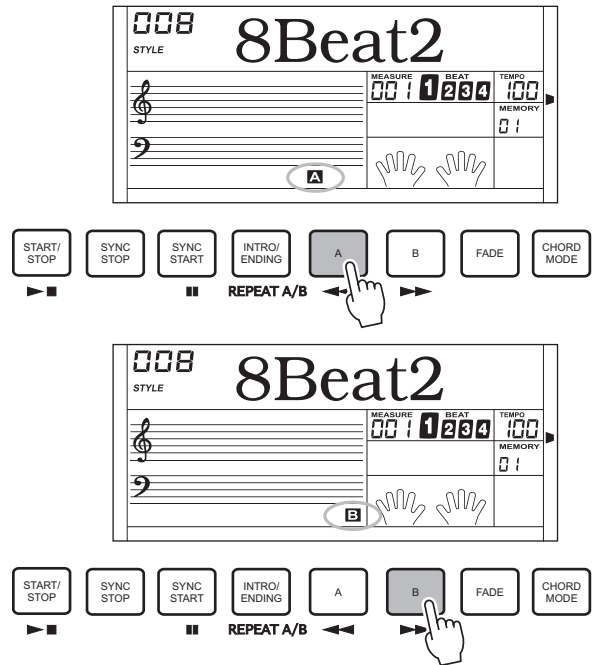

Stop a Style

- 1 **Stop immediately:**
The accompaniment can be stopped at any time by pressing the **[START/STOP]** button.
- 2 **Ending stop:**
Press the **[INTRO/END]** button, the style will stop after the ENDING section over.
- 3 **Sync Stop:**
When chord mode is on and style is not playing, press the **[SYNC STOP]** button, SYNC STOP and SYNC START LED is lightened. In this mode, press the any key in left area of keyboard to start the style playing and release the keyboard will stop it.

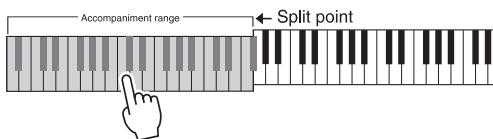

When SYNC STOP LED is lightened and style is playing, press the **[SYNC STOP]** button, the SYNC STOP LED will be darken. In this mode, the style will playing continuously.

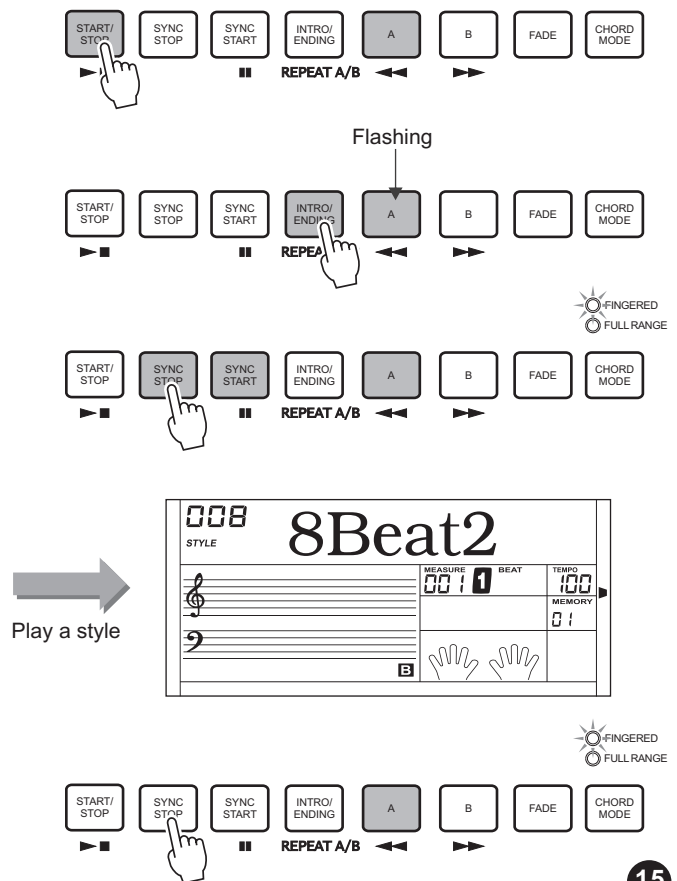

NOTE

- **[SYNC STOP]** would be enabled only when CHORD MODE indicator is on.

Fade

1 FADE IN:

Press the [FADE] button when style is not playing, "FADE" LED lights.

"FADE" LED glimmers after style begins to play, style volume will increase from 0 to maxima between 10 seconds, style is played normally subsequently, 'FADE' LED darkens.

Press the [FADE] button again while FADE OUT state, "FADE" LED glimmers, style volume will be increased to maxima on the basis of present volume, style is played normally subsequently, 'FADE' LED darkens.

2 FADE OUT:

Press the [FADE] button when style is playing, "FADE" LED glimmers, style volume will decrease from maxima to 0 between 10 seconds, style stops.

Press [FADE] button while FADE IN state, will enter FADE OUT state, volume is decrease to 0 on the basis of present volume, style stop, 'FADE' lamp goes out.

Press [FADE] button while FADE OUT state, will enter FADE IN state, volume increase to maxima on the basis of present volume, style is play normally subsequently, "FADE" lamp goes out.

Keep FADE IN state not changing as FADE IN state stops STYLE.

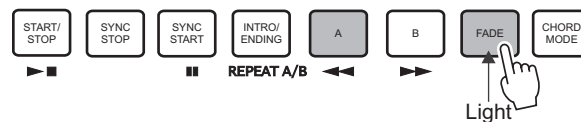
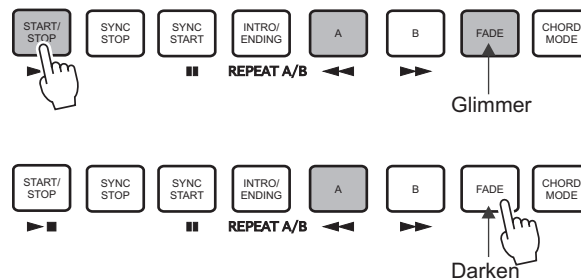
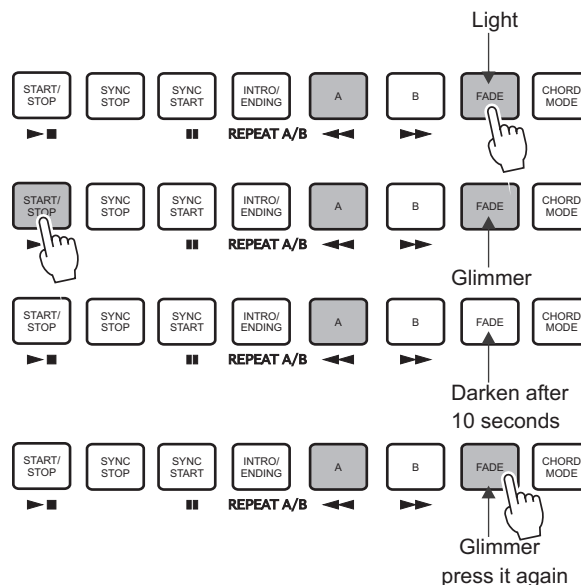

Tempo

1 Use the [TEMPO+] or [TEMPO-] button and the [+ / YES] or [- / NO] button and the DIAL to adjust the tempo from 30 to 280.

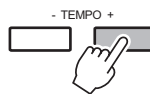

2 Press the [TEMPO+] and [TEMPO-] synchronously to set to the default tempo.

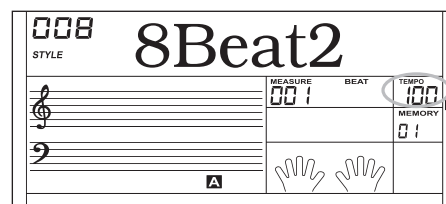
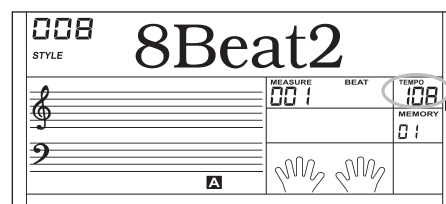
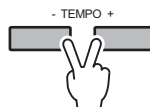

NOTE

- Selecting the style when it stops, the tempo will change with the style automatically to the default one.
- When style is playing, the tempo will not change with the style you select.

Accomp Volume

1 Press [ACCOMP +] or [ACCOMP -] button to adjust volume of accompaniment in style playing. The LCD displays the ACCOMP volume which range between 0 and 31. Default Accomp Value is 28.

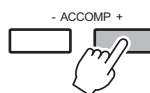

2 Press [ACCOMP +] and [ACCOMP -] button together to mute the ACCOMP track.

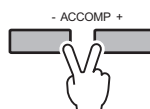

3 Press [ACCOMP +] and [ACCOMP -] button together again to turn on the ACCOMP volume.

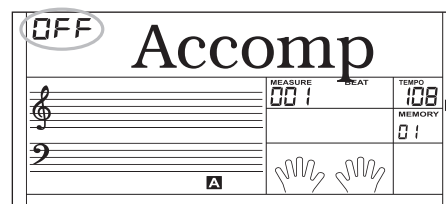
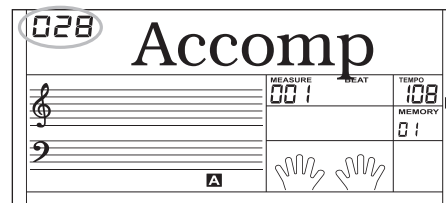

Metronome

1 Press the [METRONOME] button to turn on the metronome (the beat type can be selected in the FUNCTION menu).

2 Press the [METRONOME] button again to turn off the metronome.

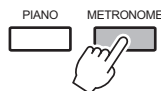

3 When the style stops to play, the beat type follows the selection in the function after turning on the metronome. When the style begins to play, the beat type follows the current style.

4 Metronome can be turned on together with the style. If the style plays at first, the metronome will respond next measure. Contrarily the metronome responds at once to the first beat of the style.

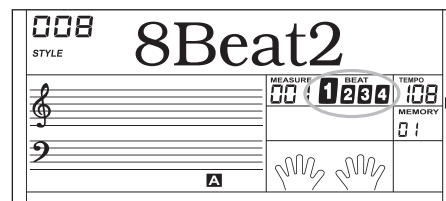

Recognizing Chords

Default mode for A.B.C. is off on the keyboard.
 Press **[CHORD MODE]** button to turn on this "auto bass chord" function. The left section of the keyboard is known as the "chord area", while playing the chord, both the bass and the chord voices sound.

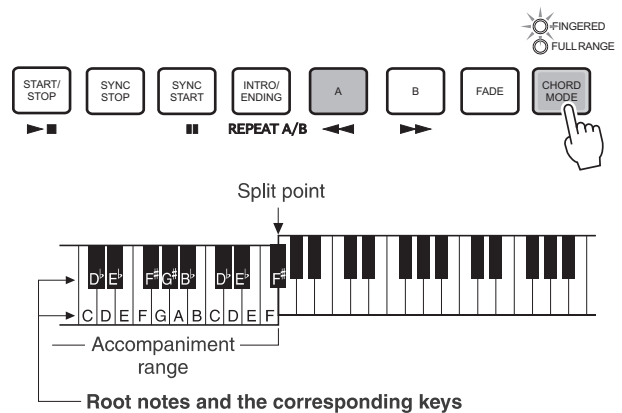

NOTE

- Since the chord detection of A.B.C. is based on the Chord Root priority, some chords that could be played under the Chord Dictionary may not be recognised by A.B.C. , eg. B6 ,bB6 ,B6(9) , bB6 ,B , Baug ,bBaug ,bBm6 ,Bm6 ,Adim7 ,bBdim7 ,Bdim.

There are 2 ways to detect the chord: "single finger detect" and "multi finger detect".

If the chord played is based on "multi finger detect", it is recognized as the "multi finger chords".
 If not, "single finger chord" will be recognized.

• Single Finger Chords

This method allows you to easily play chords in the accompaniment range of the keyboard using only one, two, or three fingers.
 The examples of Single Finger Chord "C, Cm, C7 and Cm7" are shown as below:

	<p>C</p> <ul style="list-style-type: none"> • To play a major chord Press the root note of the chord
	<p>Cm</p> <ul style="list-style-type: none"> • To play a minor chord Press the root note together with the nearest black key to the left of it .
	<p>C7</p> <ul style="list-style-type: none"> • To play a seventh chord Press the root note together with the nearest white key to the left of it .
	<p>Cm7</p> <ul style="list-style-type: none"> • To play a minor seventh chord Press the root notes together with the nearest white and black keys to the left of it (three keys altogether) .

NOTE

- When A.B.C. is on, press the keys on the left of split point. The chord will be recognized as single finger chords.

• Multi Finger Chords

This method allows you to produce an accompaniment by playing chords with normal fingerings in the accompaniment range of the keyboard.
 To play Multi Chords (Example in C chords)
 A total of 32 chords are provided as below:

0 C	1 C ₆	2 C _{M7}	3 C _{M7} (#11)	4 C _M (9)	5 C _{M7} (⁹)
6 C ₆ (⁹)	7 C _{aug}	8 C _m	9 C _{m6}	10 C _{m7}	11 C _{m7} (b5)
12 C _m (9)	13 C _{m7} (⁹)	14 C _{m7} (¹¹)	15 C _m M ₇	16 C _m M ₇ (⁹)	17 C _{dim}
18 C _{dim7}	19 C ₇	20 C _{7sus4}	21 C ₇ (b5)	22 C ₇ (⁹)	23 C ₇ (#11)
24 C ₇ (b13)	25 C ₇ (b9)	26 C ₇ (13)	27 C ₇ (#9)	28 C _{M7aug}	29 C _{7aug}
30 C _{sus4}	31 C ₁₊₂₊₅	Notes enclosed in parentheses • are optional; the chords could be recognized without them.			

• Chord Basics

Three or more notes played together constitute a "chord".

The most basic chord type is the "triad" consisting three notes: the root, third, and fifth degrees of the corresponding scale.

A "C major triad", for example, is made up of the notes C (the root), E (the third note of the C major scale), and G (the fifth note of the C major scale).

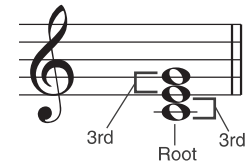

Major third – four half steps (semitones)

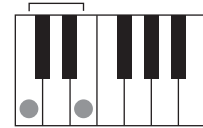

Minor third – three half steps (semitones)

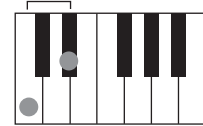

In the C major triad shown above, the lowest note is the "root" of the chord (this is the chord's "root position"...using other chord notes for the lowest note results in "inversion"). The root is the central sound of the chord, which supports and anchors the other chord notes. The distance (interval) between adjacent notes of triad in root position is either a major or minor third.

The lowest interval in our root-position triad (between the root and the third) determines whether the triad is a major or minor chord, and we can shift the highest note up or down by a semitone to produce two additional chords, as shown below.

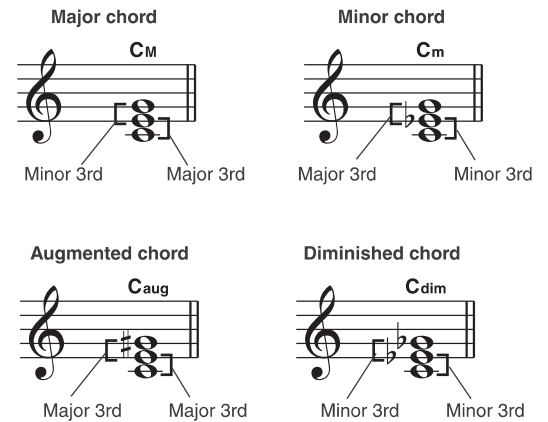

The basic characteristics of the chord sound remain intact even if we change the order of the notes to create different inversions. Successive chords in a chord progression can be smoothly connected, for example, by choosing the appropriate inversions (or chord "voicings").

• Reading Chord Names

Chord names tell you just about everything you need to know about a chord (other than the inversion/voicing). The chord name tells you what the root of a chord is, whether it is major, minor, or diminished, whether it requires a major or flatted seventh, what alterations or tension does it use...all at a glance.

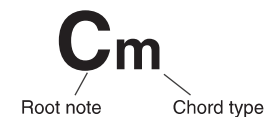

• Some Chord Types

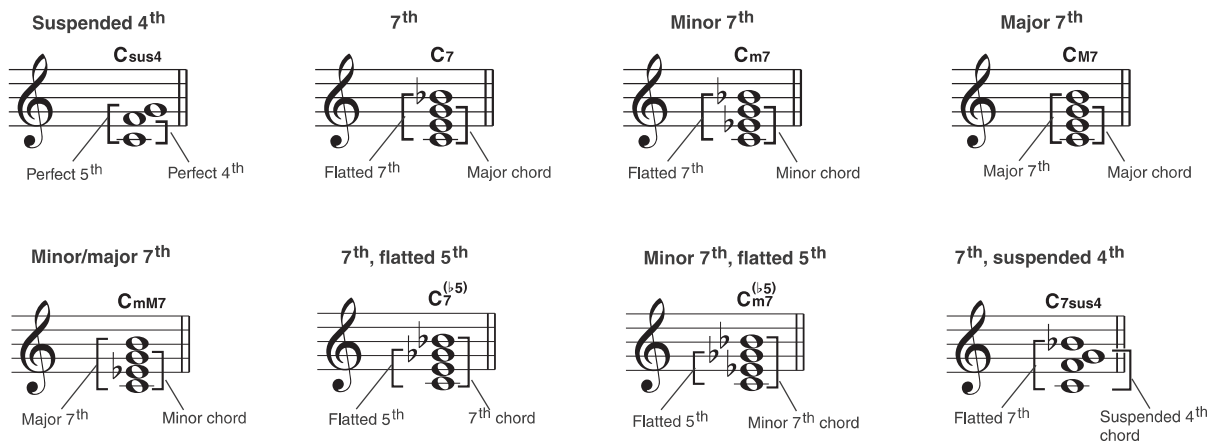

Function Menu

Press **[FUNCTION/NEXT]** or **[FUNCTION/BACK]** button to enter the menu of function. The default option of the menu is "TUNE". When you enter the menu next time, you will find the option is the same as last time. Press **[FUNCTION/NEXT]** or **[FUNCTION/BACK]** button to select the option to be set. Use **[+/YES]** / **[-/NO]** or the DIAL to set the parameter. The option and the parameters are as the follows:

NOTE

- If you don't press any button for 5 seconds after entering FUNCTION menu, it will quit this menu automatically.

Tune

This function sets the pitch of entire keyboard by steps of cents.



- 1 The LCD displays the tune value. Use **[+/YES]** / **[-/NO]** or **DIAL** to change the tune value. Its range is from -50 to 50 cents only by the right area of keyboard.

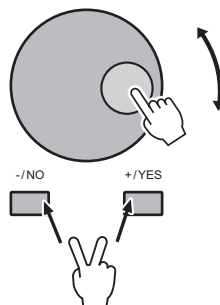

- 2 Pressing **[+/YES]** and **[-/NO]** together will set the TUNE value back to its default setting.

Beat

This function sets the beat value ranging from 0, 2-9.



- 1 The LCD displays the beat value.
- 2 Use **[+/YES]** / **[-/NO]** or **DIAL** to change the BEAT value.

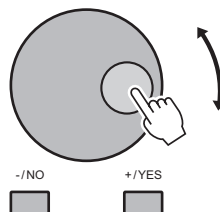

Split Point

This function sets the point that separate the entire keyboard to two section.



- 1 The LCD displays the split point value.
- 2 Use **[+/YES]** / **[-/NO]** or **DIAL** to change the split point. You may also use keyboard to change the split point by simply selecting the note you desired to be the point of separation. The part below the split point is the CHORD area.

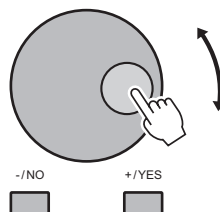

Pedal Assign

This function sets the pedal type to soft pedal, sostenuto pedal, memory select pedal, start/stop pedal. The default pedal is soft pedal.

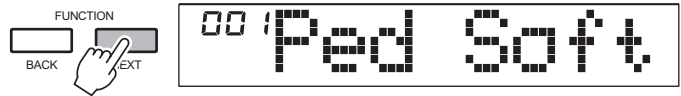

1 The LCD displays the type of pedal.

2 Use [+ / YES] / [- / NO] or DIAL to change the pedal assign.

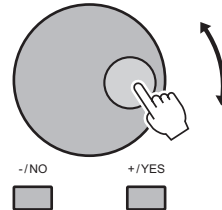

Reverb Level

1 The LCD displays the reverb level. The level ranges from 0 to 127. The default value is floating and follows the voice.



2 Use [+ / YES] / [- / NO] or DIAL to change the reverb level.

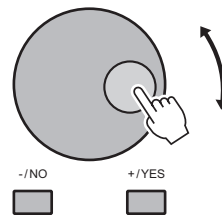

Chorus Level

1 The LCD displays the chorus level. The level ranges from 0 to 127. The default value is floating and follows the voice.

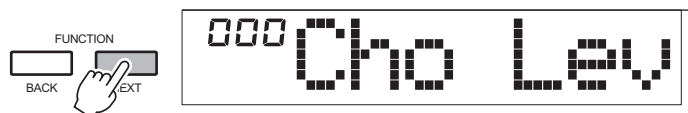

2 Use [+ / YES] / [- / NO] or DIAL to change the chorus level.

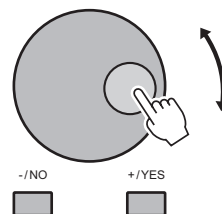

Automatic shutdown

1 This function can automatically switch off the device when not in use after 30 or 60 minutes.



2 Use the + / YES and - / NO-Tasten or the dial to set the desired value. Select OFF to disable the automatic shutdown.

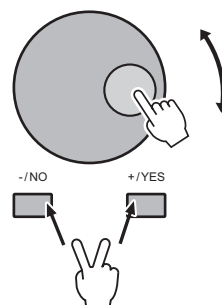

Function Menu

MIDI Setting

- 1** RECEIVE can be used to set the channel of MIDI IN. The default setting is "all". Otherwise, channel 1~16 can also be selected separately.

Use [+ / YES] / [- / NO] button or the DIAL to select the channel.

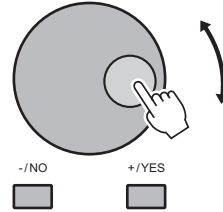

- 2** TRANSMIT can be used to set the channel of MIDI OUT. There are total of 16 channels for selection. Default setting is "001".

Use [+ / YES] / [- / NO] button or the DIAL to select the channel.



Mixer Menu

- 1** Press the [MIXER] button to enter the menu of mixer. The default option of the menu is "Rhythm_s", then the option you enter next time will be the same as last time you exit.

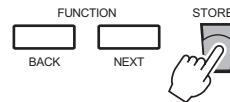

- 2** Press the [MIXER] button continuously to select the option you want, then use the [+ / YES] / [- / NO] button or the DIAL to set the parameters.

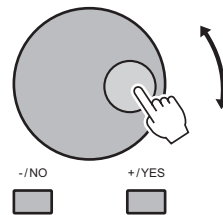

NOTE

- If you don't press any button for 5 seconds after entering the MIXER menu, it will quit this menu automatically.



The option and the parameters in detail as follows:

Option	LCD Display	Range	Default	Description
Rhythm_s Volume	026 Rhythm_s	000-031	026	percussion instrument 1
Rhythm_m Volume	026 Rhythm_m	000-031	026	percussion instrument 2
Bass Volume	026 Bass	000-031	026	bass foil
Chord 1 Volume	026 Chord1	000-031	026	symphonic melody 1
Chord 2 Volume	026 Chord2	000-031	026	symphonic melody 2
Chord 3 Volume	026 Chord3	000-031	026	symphonic melody 3
Phrase 1 Volume	026 Phrase1	000-031	026	intermezzo snippet 1
Phrase 2 Volume	026 Phrase2	000-031	026	intermezzo snippet 2
Voice R1 Volume	026Voice R1	000-031	026	single voice
Voice R2 Volume	010 Voice R2	000-031	020	dual voice
Voice L Volume	010 Voice L	000-031	012	lower voice
SD MIDI PLAY Volume	020 Sd play	000-031	020	

Memory

Memory feature can be used to preset 48 complete control-panel setups which could be recalled whenever needed.

Bank

There are 8 banks in total; each bank has 6 memories (M1~M6).

- 1 Press **[BANK]** button, the LCD displays "00x Mem Bank", with 00x showing the Bank that has been selected.

- 2 Use **[+/YES]** / **[-/NO]** button or **DIAL** to select the bank.

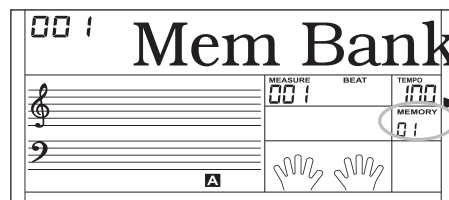
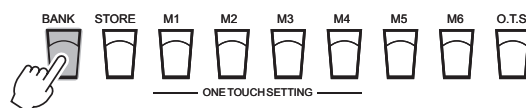

Memory Data

The data can be stored to the memory are as follows:
Voice R1, Voice R2, Voice L, Sustain, Style, Tempo, Function, Mixer, Accomp Volume and Octave.

NOTE

- If the current memory data be changed, the corresponding memory flag on LCD will be erased.

Store and Load

- 1 Press and hold the **[STORE]** button, then press the **[M1]** button (or **[M2] ~ [M6]**), the current data will be stored in them.

- 2 Press the **[M1]** button (or **[M2] ~ [M6]**) to load the data from them and replace the current parameters.

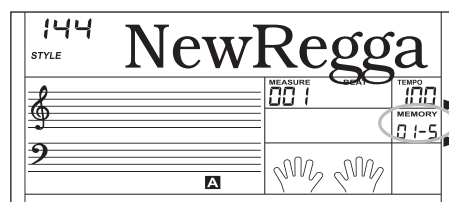
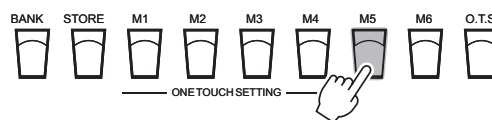
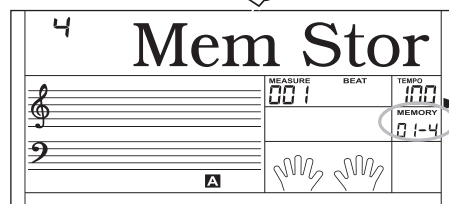
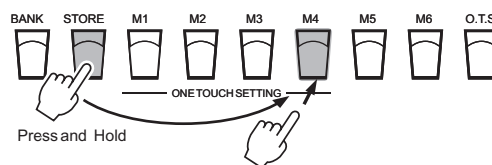

NOTE

- Press **[STORE]** and **[M1]** together while power the piano, the memory data will be set as the default value.

One Touch Setting

One Touch Setting is a powerful and convenient function that allows you to reconfigure all settings instantly with the touch of a single button. In this function, 4 types of parameters (M1~M4) will be loaded to match the current style.

- 1 Press **[O.T.S.]** button to turn this mode on and the O.T.S. flag lightens on the LCD. Press any of the **[M1]** ~ **[M4]** button, it will load the relative type of parameter to be suited for the current style. A.B.C. mode is automatically turned on during O.T.S. Mode.

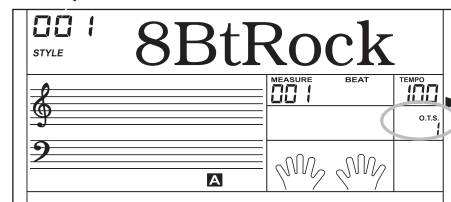
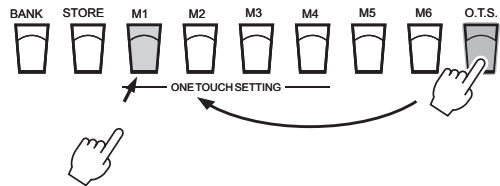

- 2 Press any of the M1-M4 buttons, which is corresponded to your desired setting.

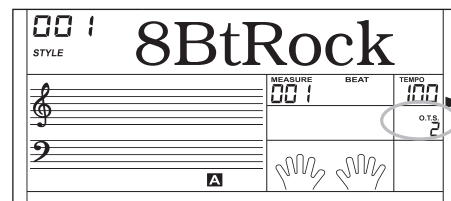
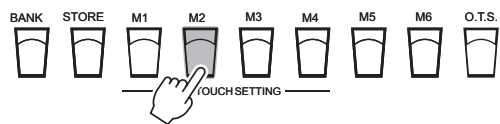

- 3 Press **[O.T.S.]** button again to turn off the O.T.S. Mode.

- 4 The default parameters stored in the O.T.S. including: Voice R1, Voice R2, Voice L, Octave, Voice R1 Volume, Voice R2 Volume, Chorus Level, Reverb Level.

Record

3 user songs can be recorded in the piano with 6 tracks (1 ACCOMP track, 5 MELODY tracks) in each song.

NOTE

- Hold down **[RECORD]** and **[PLAY/BACK]** button, then power on the piano, all recorded data will be erased.

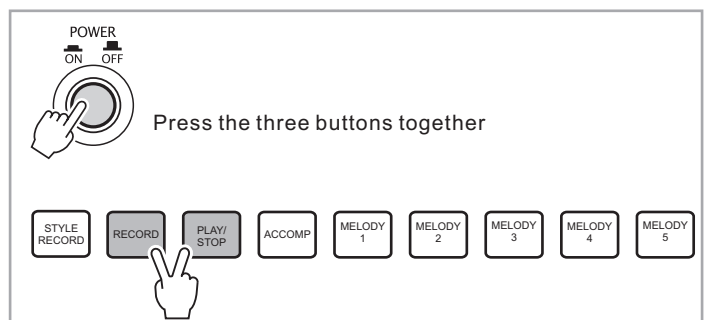

Record Song

Press the **[RECORD]** button for the first time to enter the user song selection mode. The LCD displays the current song name and number.

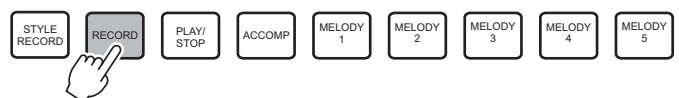

Use the **[+ / YES]** or **[- / NO]** button and **DIAL** to select one you want to record.

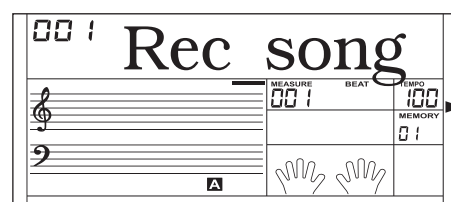

1 Waiting for recording:

Press the **[RECORD]** button for the second time to enter the record mode. The LCD lightens the REC flag, four beats flashes synchronously to indicate waiting for recording. At the same time an empty track will be selected to be recorded automatically and relative track flag flashes (the selection order is Melody1, Melody2...Melody5 and Accomp, the Melody1 will be selected while all tracks are't empty). Press the **[ACCOMP]**, **[MELODY 1]** ...**[MELODY 5]** button to select the track you want to record.

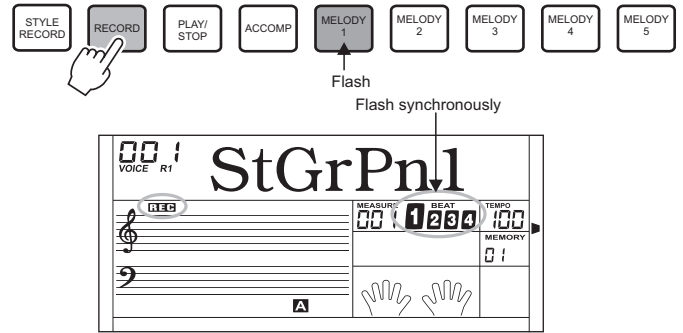

2 Start recording:

When 4 beats on LCD flashes, press the **[START/STOP]** button or play the keyboard to start recording.

NOTE

- when entering record mode, the old data of the selected track will be overwritten.

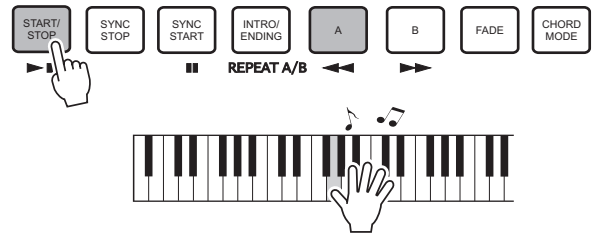

3 Choosing tracks

- There are 3 states of choosing tracks in the light buttons: Lighten, Flashing, Darken.

When the light of button is flashing, it indicates the flashing track is the track chosen to be recorded.

When the light of button is lightened, it indicates there is recorded material in this track for the selected song. Material on this track will be played simultaneously while recording for another track.

When the light of button is darkened, it indicates there's no data in this track or there's data on this track but it's forbid to play the recorded material while recording.

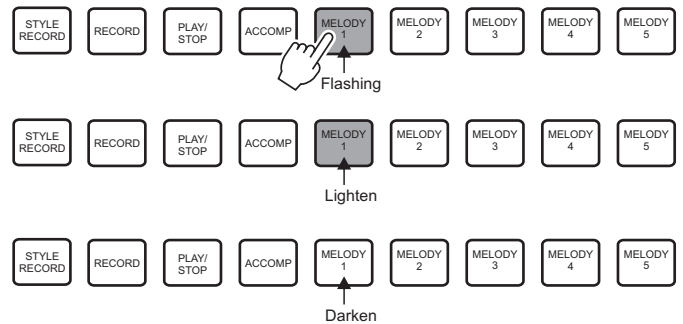

- Press "Accomp" (or "Melody 1" to "Melody 5") to select the desired track. The corresponding track will be switched between the above three states.

NOTE

- Only 1 Melody track can be recorded at a time, whereas "Accomp" track can be recorded with a Melody track at the same time.
- Style can only be recorded in "Accomp".

4 Stop recording:

Press the **[RECORD]** button for the third time to stop recording.

If Accomp track is recording, press the **[INTRO/ENDING]** button to stop recording after the ending accompaniment is over.

If the capacity is full while recording, the recording will be stopped automatically with the FULL display on LCD.

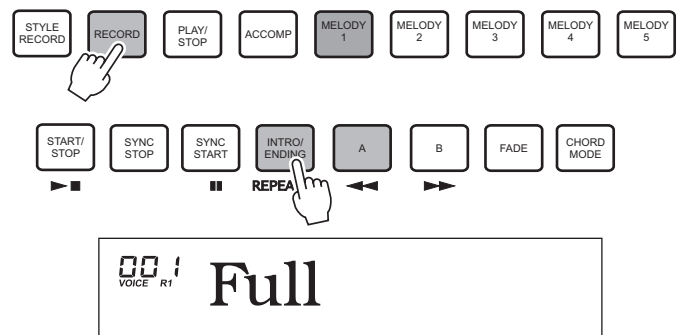

Record

Playback Song

- 1 Press the **[PLAY/STOP]** button for the first time to enter the user song selected mode. The LCD displays the current song name and number.
- 2 Use the **[+/YES]** or **[-/NO]** button and **DIAL** to select one you want to play.
- 3 Press the **[PLAY/STOP]** button for the second time to playback the user song.
- 4 Press it for the third time or to stop playback. You also can press the **[START/STOP]** button to stop it.
- 5 You can use the **[ACCOMP]**, **[MELODY 1]** and **[MELODY 5]** button to turn on or off the relative track you want to play.

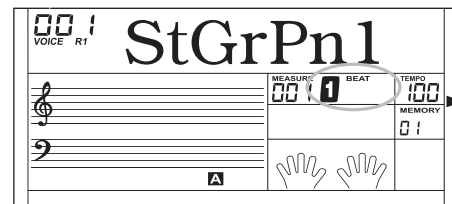
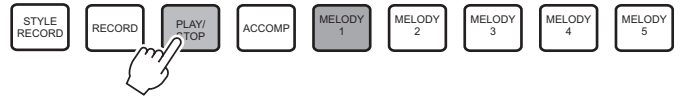
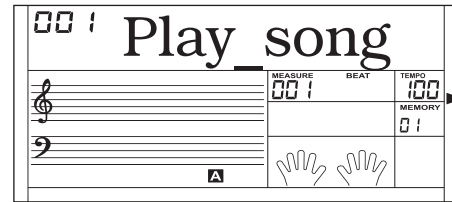
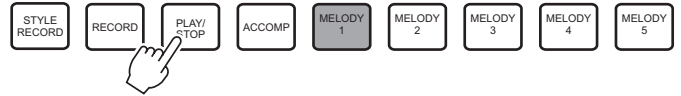

NOTE

- If there is no user song when you press **[PLAY/STOP]**, LCD will display "NULL" temporarily.



Delete Song

- 1 Press **[PLAY/STOP]** button to enter the user song selection mode.
- 2 Press **[+/YES]** / **[-/NO]** button to select the user song you want to delete.
- 3 Press **[RECORD]** button, LCD will display "DelUser".
- 4 Press **[+/YES]** button to delete the current user song. When complete, LCD displays "OK!", the cursor of the track will all darken simultaneously.

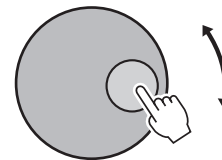
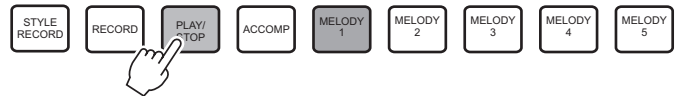

-/NO +/YES

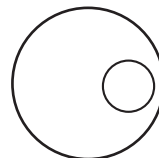
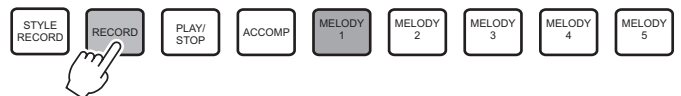

-/NO +/YES



Style Record

Style record allows user to produce a new rhythm through recording and editing an built-in style. Be note that the built-in rhythm are programmed with CM7.3 styles can be recorded and the data will not be lost after the power is off. You are also allowed to save the recorded style to SD card.

Before recording, you need to choose a rhythm as the original rhythm. This rhythm can be chosen from any of the existing 200 styles and you can also select your recorded style as original rhythm.

The style must be recorded by paragraph and by track. After finishing recording a track of a paragraph, you may proceed to record a different track of the same paragraph of a different paragraph.

Structure of a Rhythm:

Rhythm includes 8 paragraphs at most:

- Main _ A
- Main _ B
- Intro _ M (major)
- Intro _ m (minor)
- Fill _ A (insert in a)
- Fill _ B (insert in b)
- Ending _ M(major)
- Ending _ m(minor)

Each paragraph includes 8 tracks at most:

- Rhythm sub (rhythm subsidiary)
- Rhythm main
- Bass
- Chord 1 (symphonic 1)
- Chord 2 (symphonic 2)
- Chord 3 (symphonic 3)
- Phrase 1
- Phrase 2

Attention:

If you power off the piano during style recording, the recording data will be lost.

Start Style Record

- 1 Press the **[STYLE RECORD]** button, LCD display the current user style.

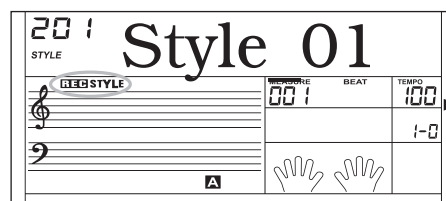
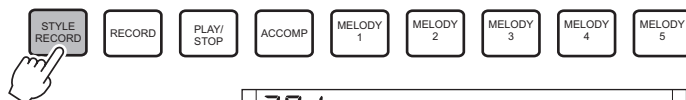

- 2 Use the **[+ / YES]** or **[- / NO]** button and **DIAL** to select the others.

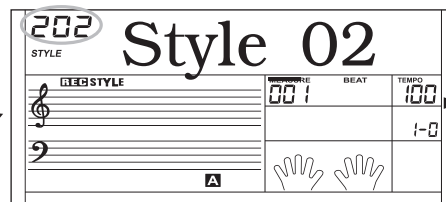
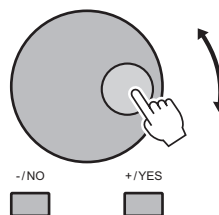

- 3 Then press the **[FUNCTION/NEXT]** button to enter next menu, at first LCD display the RECORD menu.

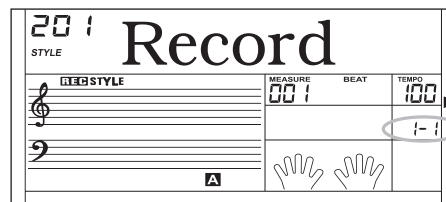
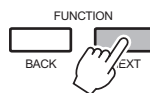

Style Record

- 4 Use the **[+/YES]** or **[-/NO]** button and **DIAL** to select the others includes Record, Copy, Quantify, Edit and Delete.

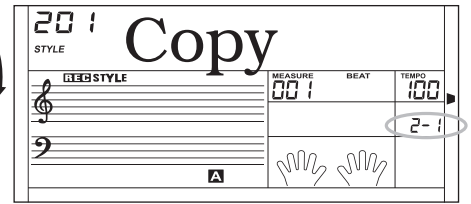
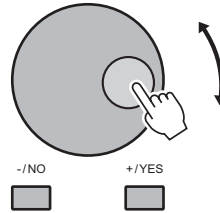

- 5 If the user style selected is empty, only Record and Copy can be selected.

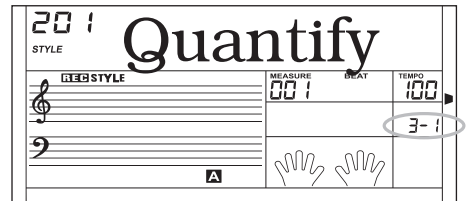

- 6 At any moment of style recording state, pressing **[STYLE RECORD]** button again will exit from the recording state. The data will not be saved.

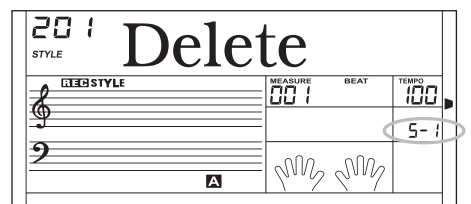
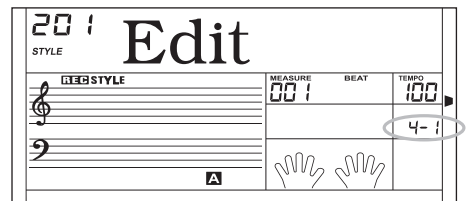

Record a new Style

- 1 Select RECORD in style record menu level1.

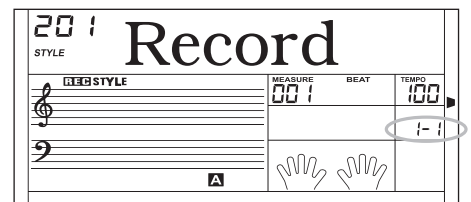
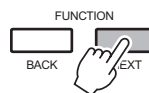

- 2 Press **[FUNCTION / NEXT]** to enter record mode menu. LCD now displays "Overdub".

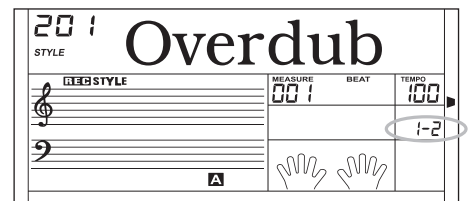
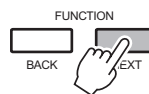

Press **[+/YES]**, **[-/NO]** button or rotate the **DIAL** to select a recording mode. 2 options for recording mode: overdub and replace.

In Overdub mode, the newly recorded data will be added to the original style data.

In Replace mode, the original style data will be overwritten with the newly recorded data.

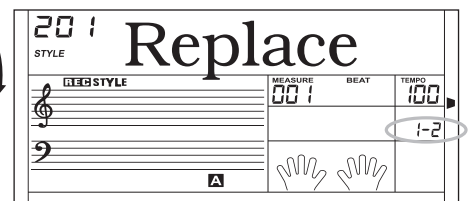
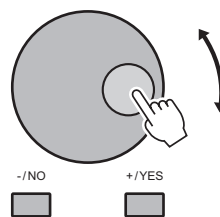

- 3** Press **[FUNCTION / NEXT]** to enter rhythm selection menu.

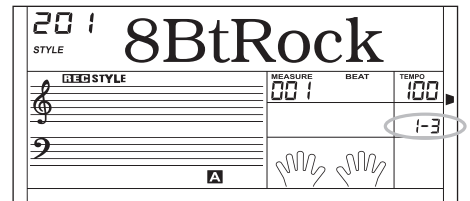
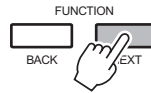

Press **[+/YES]**, **[-/NO]** button or rotate the **DIAL** to select a original rhythm.
Press **[FUNCTION / BACK]** to return previous menu.

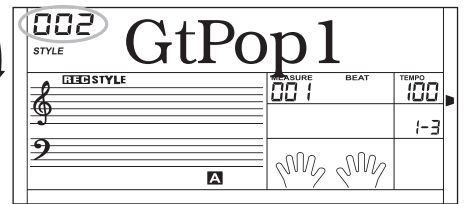
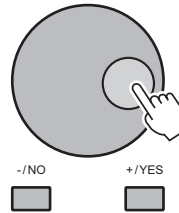

- 4** Press **[FUNCTION/NEXT]** button to enter the paragraph menu.

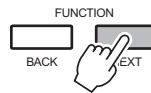

Press **[+/YES]**, **[-/NO]** button or rotate the **DIAL** to select the paragraph of rhythm. There are 8 paragraphs to be selected includes: Main _A, Main _B, Intro _M, Intro _m, Fill _A, Fill _B, Ending _M, Ending _m.

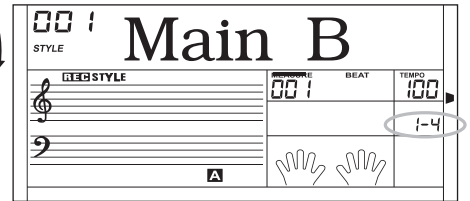
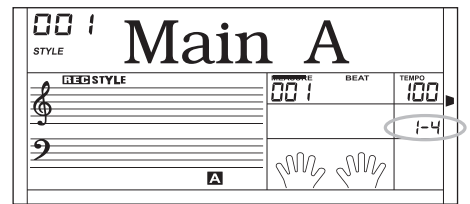
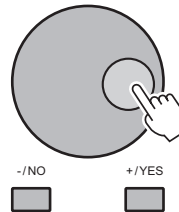

- 5** Press **[FUNCTION/NEXT]** button to enter the paragraph menu.

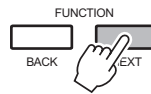

Press **[+/YES]**, **[-/NO]** button or rotate the **DIAL** to select the track: Rhythm sub, Rhythm main, bass, chord 1, chord 2, chord 3, phrase 1, phrase 2.

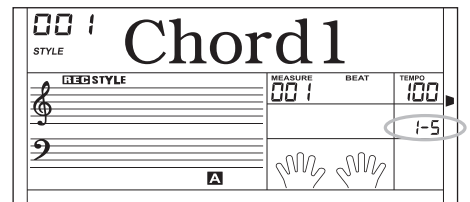

- 6** Press the **[FUNCTION / NEXT]** button to enter the record ready menu.

The style record is on the synchronized start mode, and the beat display will flash at the current tempo.
At that time you can use the **[+/YES]**, **[-/NO]** button or **DIAL** or direct select buttons to change the voice for the current track. If you've picked the drum track, you would only have drum kits for selection.
Press the **[FUNCTION / BACK]** button to return previous menu.

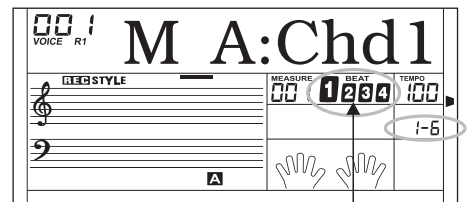
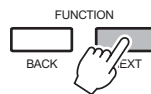

Flash together

- 7** Press the **[START/STOP]** button to start recording.

The style will play with CM7 chord, the selected paragraph of the original rhythm begins to play in a loop way. Play the keyboard to record, the recorded data in current loop would be replayed in next loop. Also you can delete the note being recorded in last loop by pressing the same note at same time in next loop within 1/8-quarter note around it played.

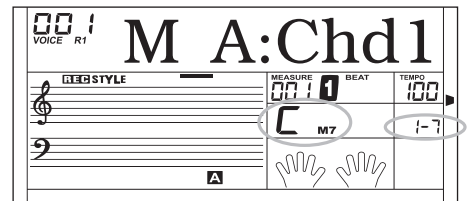
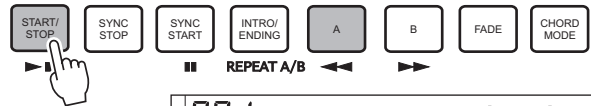

- 8** Press the **[START/STOP]** button again to stop recording and return to the synchronized start state.

- 9** Press the **[STYLE RECORD]** button to exit the current mode. You can also repeat the operation by pressing the **[FUNCTION / BACK]** button to return previous menu and select other options.

Copy a Style

- 1 Select a user style slot to be used to store the new style.

Press **[FUNCTION/NEXT]** button to enter choice menu.

Press **[+/YES]**, **[-/NO]** button or rotate the **DIAL** to choose "Copy".

- 2 Press **[FUNCTION/NEXT]** button to enter rhythm selection menu.

Press **[+/YES]**, **[-/NO]** button or rotate the **DIAL** to select a user style that needs to be copied.

- 3 Press **[FUNCTION/NEXT]** button to enter next menu.

LCD now displays: "Sure?".

Press **[+/YES]** to confirm, otherwise press **[-/NO]** to return to previous menu.

- 4 Press **[+/YES]** to finish copy.

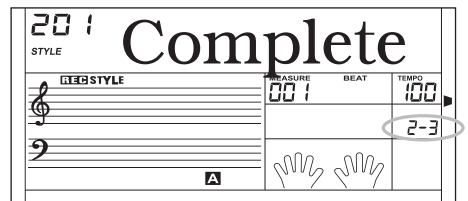
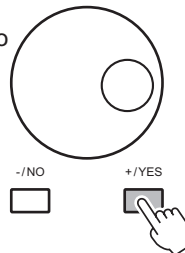
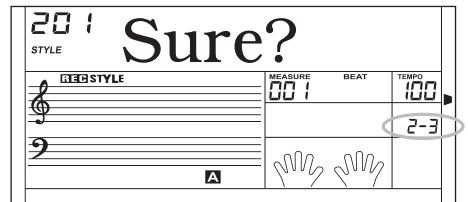
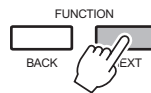
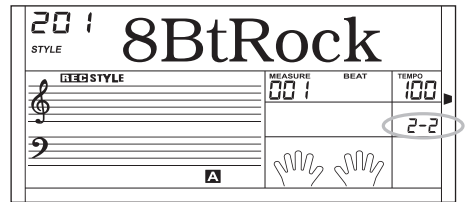
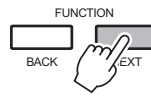
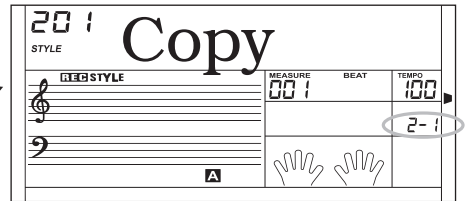
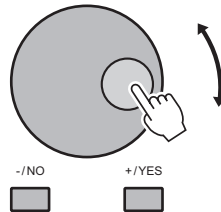

Quantify a Style

As timing of the recording may not be as accurate as it should be, Quantization helps users to correct the timing by aligning the notes to the exact beat. We'd suggest choosing the shortest note of the piece as the quantization precision for best result. If a lower quantization precision is chosen, for example choosing a quarter note as the precision when the shortest note is a 16th, the note with the short duration may be filtered.

- 1 Select the user style that needs to be quantified.

Press **[FUNCTION/NEXT]** to enter choice menu.

Press **[+/YES]**, **[-/NO]** button or rotate the **DIAL** to choose "Quantify" (if there is no data in user style, this menu can not be selected).

- 2 Press **[FUNCTION/NEXT]** to enter Quantization Precision menu.

Press **[+/YES]**, **[-/NO]** button or rotate the dial to select the accuracy for quantifying. Quantity accuracy includes 1/4 (quarter), 1/4 Tri (Quarter Triplet), 1/8 (Eighth), 1/8 Tri (Eighth Triplet), 1/16 (Sixteenth), 1/16 Tri (sixteenth Triplet), 1/32 (32nd), 1/32 Tri (32nd Triplet).

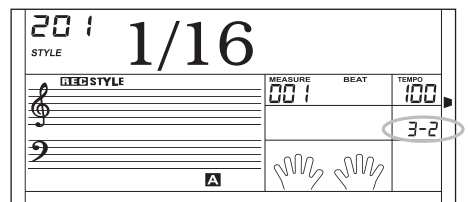
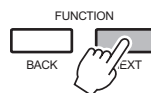
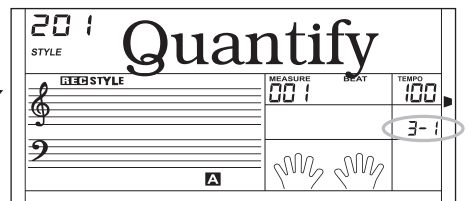
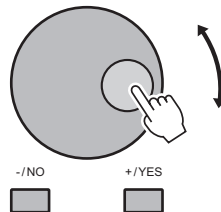

Quantization Precision value

 quarter note

 eighth note

 sixteenth note

 thirty-second note

 quarter note triplet

 eighth note triplet

 sixteenth note triplet

 thirty-second note triplet

- 3** Press **[FUNCTION/NEXT]** to enter the paragraph menu.

Press **[+/YES]**, **[-/NO]** button or rotate the **DIAL** to select the paragraph of rhythm: Main _ A, Main _ B, Intro _ M, Intro _ m, Fill _ A, Fill _ B, Ending _ M, Ending _ m.

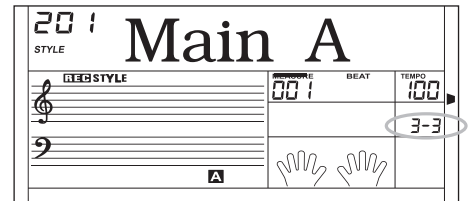
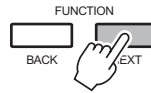

- 4** Press **[FUNCTION/NEXT]** to enter the Track menu.

Press **[+/YES]**, **[-/NO]** button or rotate the **DIAL** to select the track: Rhythm sub, Rhythm main, bass, chord 1, chord 2, chord 3, phrase 1, phrase 2.

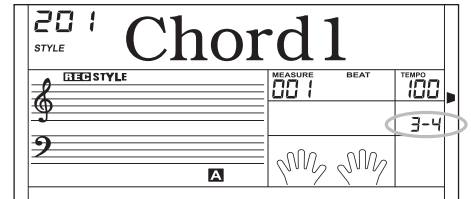
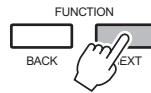

- 5** Press **[FUNCTION/NEXT]** to enter next menu.

LCD now displays "Sure?".

The original time and length of note will not be recovered after quantization.

Press **[+/YES]** to confirm. Style will be quantified accordingly. Otherwise, press **[-/NO]** to return to previous menu.

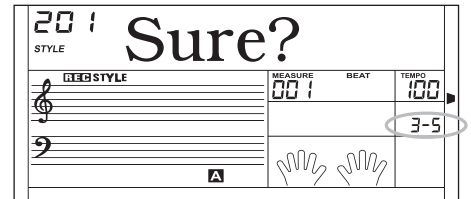
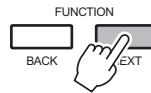

- 6** LCD displays "Complete". The recorded style will be played with the desired accuracy.

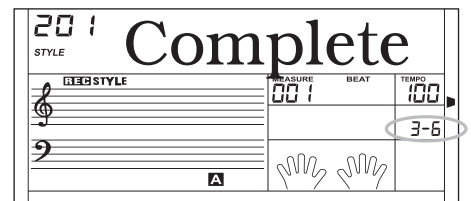
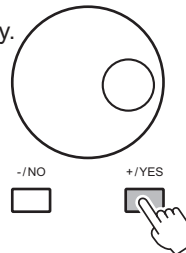

Edit a Style

Select the style that needs to be edited.

- 1** Press **[FUNCTION/NEXT]** button to enter choice menu.

Press **[+/YES]**, **[-/NO]** button or rotate the **DIAL** to choose "Edit".

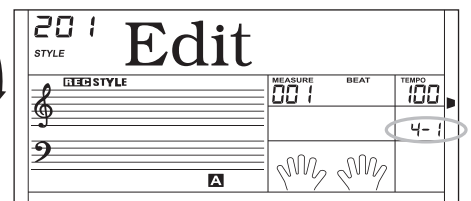
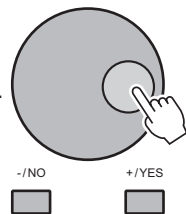

- 2** Press **[FUNCTION/NEXT]** button to enter tempo edit menu.

Press **[+/YES]**, **[-/NO]** button or rotate the **DIAL** to modify tempo.

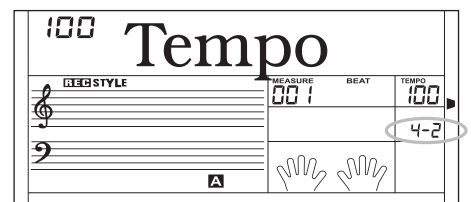
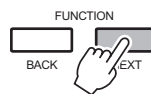

- 3** Press the **[FUNCTION/NEXT]** button to enter the rename menu (full name).

Use the keyboard to input the style whole name. It may include 26 letters and characters with the most length of 32 characters.

Press the **[FUNCTION/BACK]** button to return previous menu.

Please refer to page 42 for naming function.

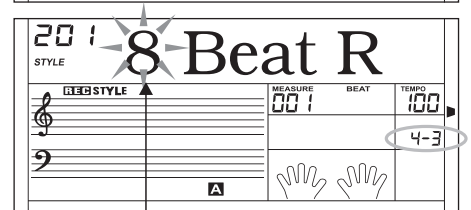
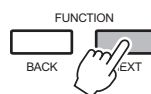

Flash

Style Record

- 4** Press **[FUNCTION/NEXT]** button to enter page of the abbreviation of style name.

Only 8 characters or digits can be inputted.

LCD now displays "Save? "

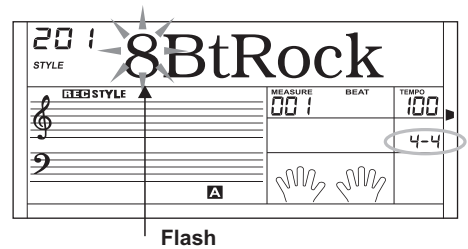
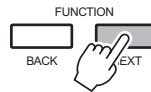

Flash

- 5** Press **[FUNCTION/NEXT]** button to enter next menu.

Press **[+/YES]** to confirm, otherwise press **[-/NO]** to return to previous menu.

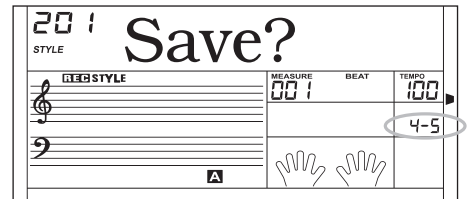
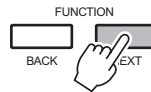

- 6** Press **[+/YES]** to finish editing.

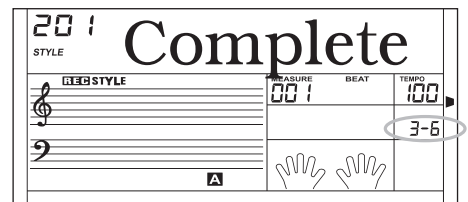
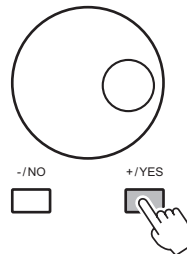

Delete a style

Select the user style that needs to be deleted.

- 1** Press **[FUNCTION/NEXT]** button to enter choice menu.

Press **[+/YES]**, **[-/NO]** button or rotate the **DIAL** to choose "Delete".

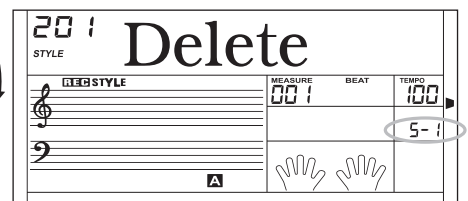
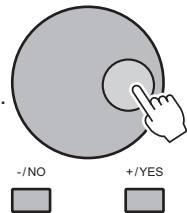

- 2** Press **[FUNCTION/NEXT]** button to enter Paragraph Selection page.

Press **[+/YES]**, **[-/NO]** button or rotate the **DIAL** to select the paragraph that needs to be deleted.

If All is selected, the menu will jump to step 4.

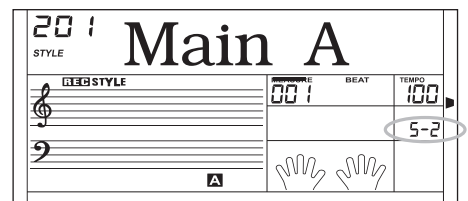
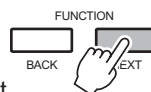

- 3** Press **[FUNCTION/NEXT]** button to enter Track Selection page.

Press **[+/YES]**, **[-/NO]** button or rotate the **DIAL** to select the track that needs to be deleted.

If all is selected, the rhythm will be deleted.

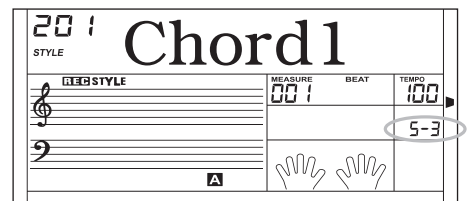
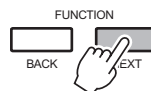

- 4** Press **[FUNCTION/NEXT]** button to enter next menu.

LCD now displays "Sure?".

Press **[+/YES]** to confirm. Press **[-/NO]** to return to previous menu.

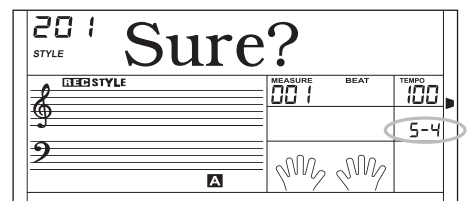
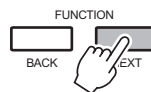

- 5** Press **[+/YES]** to finish deleting.

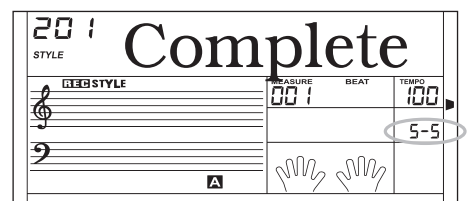
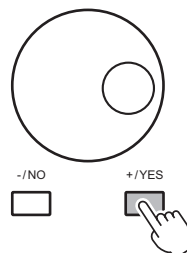

Song

There are 100 songs in total, includes 57 songs with left and right melody parts, 33 style songs and 10 piano songs.

1 START/STOP the song:

Press [SONG] button to enter the song mode, the song flag on LCD is lightened. It will play all songs in circle.

Press [START/STOP] button to stop playing the song, but it will not quit the song mode.

2 Loop:

The 2nd time you start playing the song by pressing [START/STOP] button, it will play current song repeatedly.

3 Select the song:

Use [+ / YES] / [- / NO] button or DIAL to select the song you want. If select the new, LCD will displays its whole name at first with roll and then stays in shortened form.

4 Song control:

Introductory beat:

Before the song start playing, it has the introductory beat, the measure starts from negative value. It begins to play the song when the measure goes to 1.

REW, FF and PAUSE:

When the song is playing, hold the [▶▶] button to fast forward the song.

Hold the [◀◀] to rewind the song (base on the measure).

Press the [⏸] to pause the playing song.

Song repeat

When playing the song, press [REPEAT A/B] button to set the location of loop begin and loop end to the current song. Press the [REPEAT A/B] to set the loop begin, and press the [REPEAT A/B] twice to set the loop end. When in loop status, press [REPEAT A/B] again to quit loop playing status.

5 When the song is stopped, press [STYLE], [VOICE] and [DEMO] button will exit the song mode, or hold the [CHORD DICTIONARY] button to enter Chord Dictionary mode.

NOTE

- The user song do not have the function of REW, FF and PAUSE.

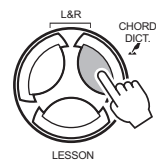
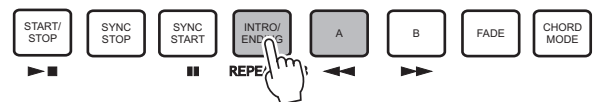
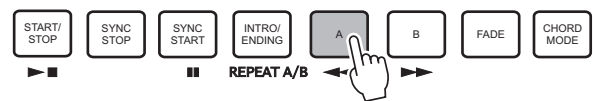
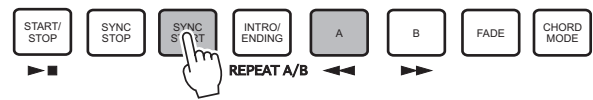
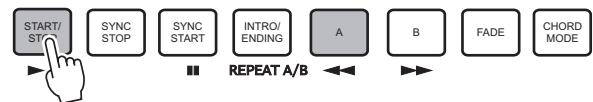
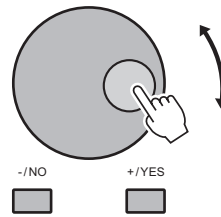

Lesson Mode

There are 2 different ways to practice the songs by the time value training and note correction training. And the piano offers the GRADE function to help you better know your progress.

In song mode (Song is not playing), press [LESSON] button to enter lesson mode.

There are 3 levels to score the performance of your playing. You can use [R] and [L] button to select which hand to practice. If neither hand is selected, the keyboard will choose the right hand automatically.

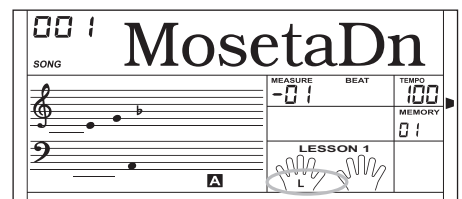
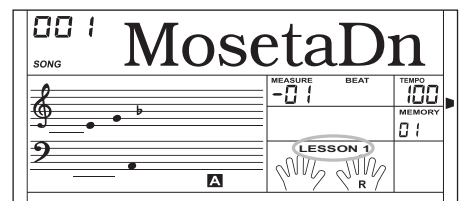
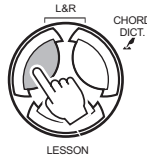
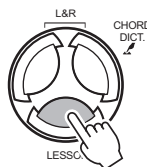

NOTE

- According to the type of the song, the content of your practice by left hand is not the same. If you choose chord song, the left hand practices the chord, otherwise, left hand practise the melody.
1-42, 57 song can permission practice the left hand and right hand. 43-56 , 58-100 song only used to right hand practice.
- When the song is playing, the staff displayed on the LCD indicate the melody and chord position, LCD shows the last note played by RIGHT track, and it will be convenient for you to practice .
Because the melody track note span of song may exceed the range that staff can reveal, staff high notes district might have +12, +24 display at this moment, show whom staff reveal high one octave or two octave of notes at present.
The display of this +12, +24 chord to style song is invalid, Chord of style song reveal first octave in staff bass all the time when revealing +12/+24, study chord part time according to chord bond potential prompt play the musical instruments or play the musical instruments transposition chord all validity.

Lesson 1-Practice timing

Press **[LESSON]** button to enter the lesson mode, the lesson 1 flag is lightened on LCD.
In LESSON 1 mode, the piano only grade the time value of the playing, accuracy of note playing will not be accounted for.

1 Press **[START/STOP]** to start to practise.

2 If **[R]** is selected; it will mute the melody of right hand and you will have to follow the timing of the right hand. As long as the timing is correct, the melody will sound.

If **[L]** is selected ; it will mute the changing chord and melody by left hand. You will have to follow timing of the left hand. As long as the timing is correct, the chord / melody will sound.

If **[L]** and **[R]** are selected, the melody on left and right hand will be muted. You will have to follow timing on both left and right hand.

3 Once completed, the result of evaluation will be voiced.

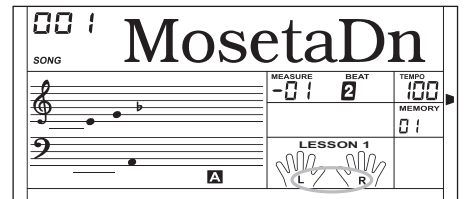
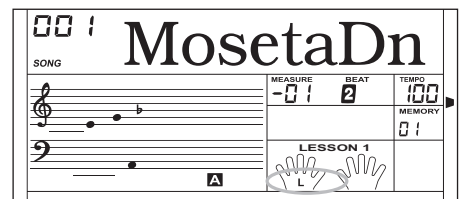
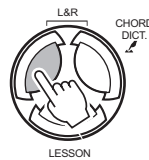
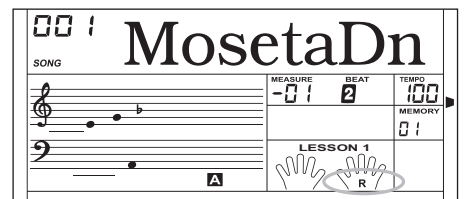
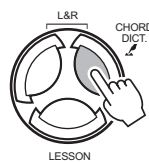
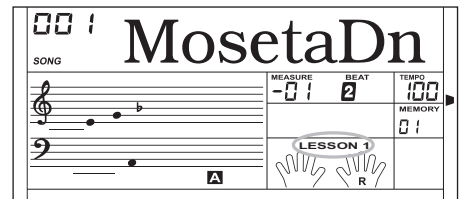
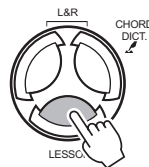

Lesson 2-Practice a note accuracy

Press **[LESSON]** button again to enter the lesson 2 mode.

In LESSON 2 mode, the piano only grade your practice by the note, accuracy of time value will not be considered as the song will only continue to the next when the correct note is played.

Only when you play the correct note, the song will continue to the next note.

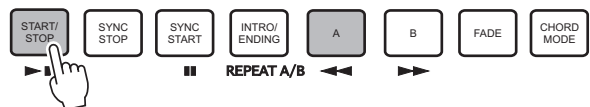
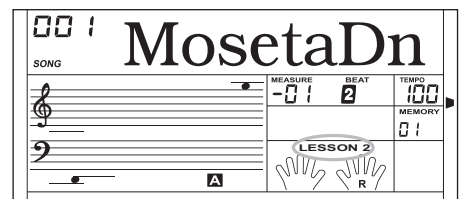
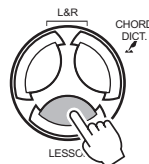

Press **[START/STOP]** button to start to practise.



Lesson 3

Press [LESSON] button in LESSON 2 to enter the LESSON 3 mode.

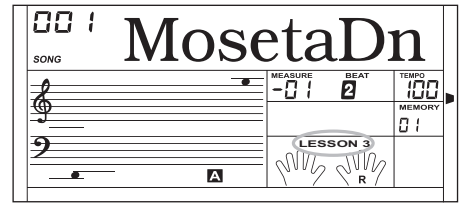
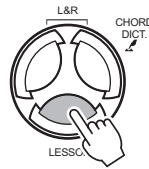

In LESSON 3 mode, it will score your practice by the correction of the time value and note.

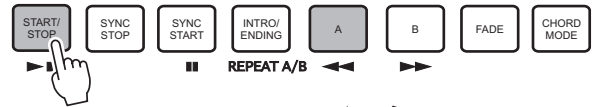

Press [START/STOP] button to start to practise.



Chord Dictionary

Chord dictionary is essentially a built-in "chord book" that help you to check the Chord notes. It is ideal when you know the name of a certain chord and want to quickly learn how to play it.

1 DICT 1 (CHORD LEARNING MODE)

Press and hold the [CHORD DICT./R] button for longer than 2 seconds to enter DICT 1 mode.

In this mode, the keys above C4 are used to assign the Chord Type, the keys above C6 are used to assign the Chord Root.

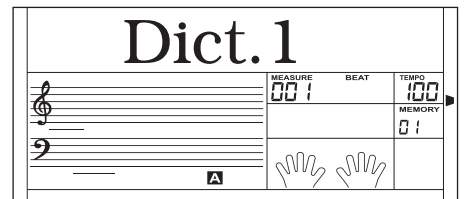
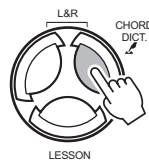

When the Chord Type and Chord Root is confirmed, The LCD will display the Chord and its keyboard position.

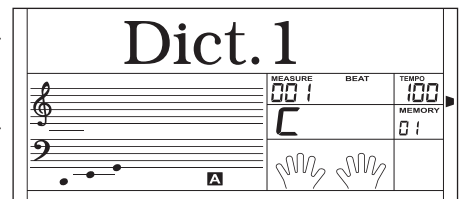
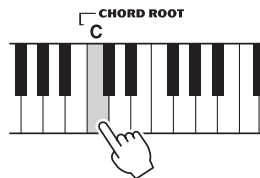

For example, if we want to play a Cm7 Chord. Press the C key in the section of the keyboard labeled CHORDROOT. (The note does not note sound) the root note you set will be shown on the display.

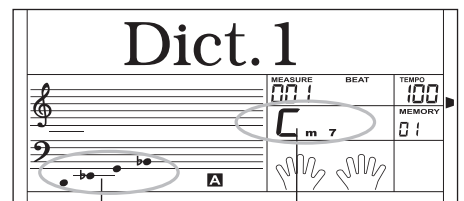
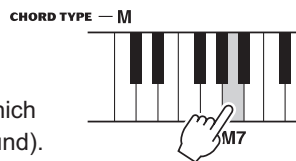

Press the m7 key in the section of the keyboard which has labeled CHORD TYPE (The note does not sound). The notes you should pay for the specified chord (root not and chord type) are shown in the display as the notation and also in the keyboard diagram.

Notation of chord

Chord name (root and type)

Chord Dictionary

2 DICT 2 (CHORD TEST MODE)

Press [R] button again to enter DICT 2 mode. The chord area on the LCD will display a random chord, while the keyboard position doesn't display anything on LCD. When you play the correct chord within 3 seconds, the next chord (random) will be displayed on LCD to wait for the correct chord playing, if not, LCD displays the corresponding keyboard position automatically.

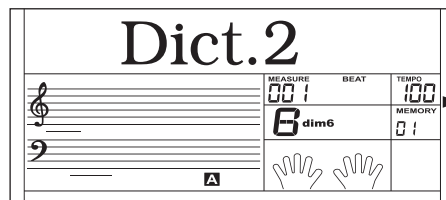
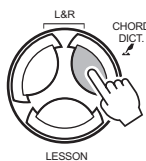

Press [R] button for the third time to turn off chord dictionary.

24 chords will be displayed in the dictionary mode as follows:

Chord Root:

Note	Chord Root	Note	Chord Root
C6	C	F [#] 6	F [#] G ^b
C [#] 6	C [#] /D ^b	G6	G
D6	D	A ^b 6	A ^b / G [#]
E ^b 6	E ^b / D [#]	A6	A
E6	E	B ^b 6	B ^b / A [#]
F6	F	B6	B

Chord Type:

Note	Chord Type	Note	Chord Type
C4	M	C5	7(b9)
C [#] 4	M(9)	C [#] 5	7(9)
D4	6	D5	7(#9)
E ^b 4	mM7	E ^b 5	7(b13)
E4	M7	E5	7(13)
F4	m	F5	7(#11)
F [#] 4	m(9)	F [#] 5	dim7
G4	m6	G5	dim
A ^b 4	m7(9)	A ^b 5	7aug
A4	m7	A5	aug
B ^b 4	m7b5	B ^b 5	7sus4
B4	7	B5	sus4

Pedal

Foot Switch

The keyboard can assign the pedal in function menu.
(See FUNCTION)

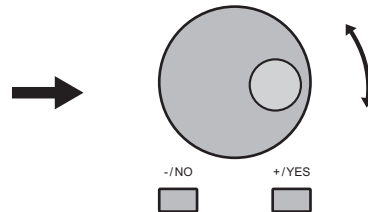
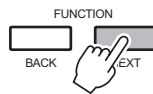

1 PEDAL SOFT

If pedal assign is set as "pedal soft", it will activate the soft effect when you step the pedal.



2 PEDAL SOSTENUTO

If pedal assign is set as "sostenuto", the notes played before you step on have a sustain effect. Release the pedal, sostenuto effect is turned off.



3 PEDAL MEMORY SELECT

If pedal assign is set as "pedal mem", it will load the next memory parameter when you step the pedal.



4 PEDAL START/STOP

If pedal assign is set as "pedal ST/S", the pedal will have the same function as [START/STOP] button.



SD Function

There is a standard SD external interface which supports SD cards with capacity of 16M ~ 2G. It is compatible with the FAT 16/32 file system format.

Press the [MENU] button to enter the SD CARD sub menu which includes: PLAY, LOAD, SAVE, DELETE and FORMAT.

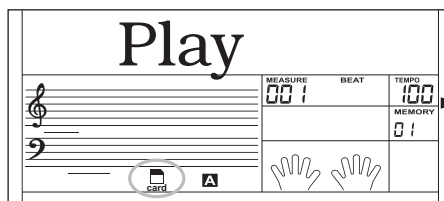
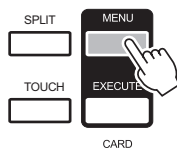

If there is no card, it will display "No Card", then you can press [MENU] to exit. Otherwise, "Wait...!" will disappear temporarily for 3 seconds then it will show "Play" on the LCD.

1 You can also press any **DIRECT SELECT BUTTON** / [VOICE] / [STYLE] / [SONG] / [DEMO] / [DUAL] / [SPLIT] / [PIANO] to exit SD CARD menu.

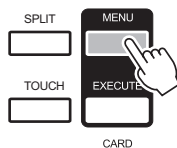

2 In midi play mode, you can press mixer button then press [+/YES], [-/NO] button to adjust the volume to play.

3 In SD card mode, you could press [MENU] button repeatedly to exit sd menu step by step, you also could press and hold [MENU] button for 2 seconds to exit directly.

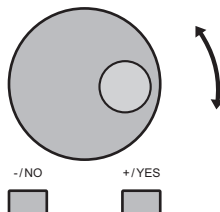

SD Function

In the SD mode, it won't respond to the other function.
Use the **[+/YES]**, **[-/NO]** button and **DIAL** to choose the SD menu you want.

Press the **[EXECUTE]** button to take a step forward.
Press the **[MENU]** button to take a step back.

Please refer to page 42 for naming function.

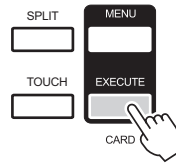

d FOLDER01

Play

- 1 Select the menu "Play" and press the **[EXECUTE]** button, LCD will display the MIDI files and directories in the root of the SD card.

If the MIDI file in SD could be identified and selected, LCD will display file name and the "F" sign.

If there is no midi file identified inside the current directory, LCD will display the sub-directory name and the "d" sign. Press the **[EXECUTE]** button to enter the current sub-directory, then new MIDI files or subdirectories of the directory will be displayed.

If there is neither MIDI file nor subdirectory in the current directory, LCD will display ". ." and the "d" sign, you can press the **[EXECUTE]** button to exit the directory.

If there is neither MIDI file nor subdirectory in the root , LCD will display "No file".

- 2 Use the **[+/YES]**, **[-/NO]** button and **DIAL** to select the MIDI file.

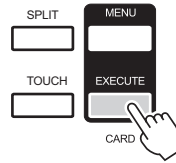

Play

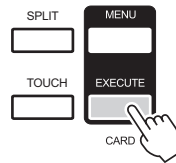

F SNG_1111

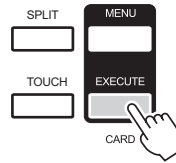

d FOLDER01

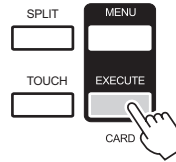

d ..

No File

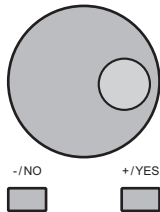

F SNG_1111

Then press the **[START/STOP]** button to play it repeatedly.

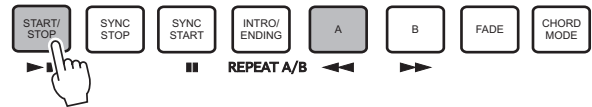

Press the **[EXECUTE]** button to play all files in the current directory circularly.

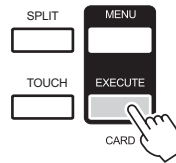

NOTE

- When the file is playing, you can select new file in the current directory or other subdirectory.
- When the file is playing, you can adjust the tempo with the **[TEMPO +]**, **[TEMPO -]** button, press them synchronously, the current tempo will reset the default one of the file.

- 3 When the file is playing, press the **[START/STOP]** button to stop playing. Also you can press the **[MENU]** button to return PLAY menu, or press the **[MENU]** button 2 seconds to exit the SD mode, then stop to play the file.

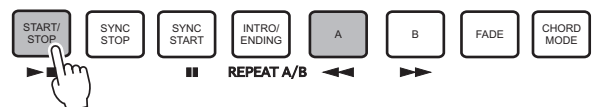

Load

Select the menu "Load" and press the **[EXECUTE]** button, the Load menu are displayed on the LCD, it includes "Load Song", "LoadSty" and "LoadMem". Use the **[+/YES]**, **[-/NO]** button and **DIAL** to select one.

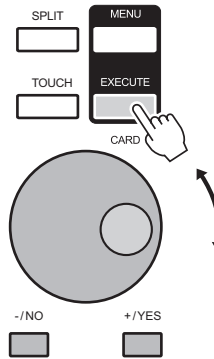

Load

LoadSong

LoadSty

LoadMem

1 Load Song

Select the menu "LoadSong" and press the **[EXECUTE]** button, the user songs you saved or directory in the root of SD are displayed on the LCD, the main name of the file includes 8 characters, the postfix name is MID. You can select songs with **DIAL** or the **[+/YES]** & the **[-/NO]** button.

Press the **[EXECUTE]** button to confirm the desired file, the empty user song slot will be displayed on the LCD, you can select them with dial or the **[+/YES]** and the **[-/NO]** button.

Press the **[EXECUTE]** button, "Sure?" will be displayed on the LCD.

You just need to press the **[EXECUTE]** button to load the file.

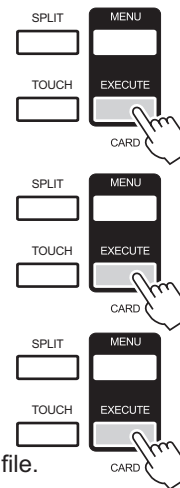

LoadSong

F SNG_0001

00 ! UserSong

00 ! Sure?

00 ! Wait...!

2 Load Style

Select the menu "LoadSty" and press the **[EXECUTE]** button, the user styles you saved or directory in the root of SD are displayed on the LCD, the main name of the file includes 8 characters, the postfix name is STY. You can select styles with dial or the **[+/YES]** & the **[-/NO]** button.

Press the **[EXECUTE]** button to confirm the desired file, the empty user style slot will be displayed on the LCD, you can select them with dial or the **[+/YES]** & the **[-/NO]** button.

Press the **[EXECUTE]** button, "Sure?" will be displayed on the LCD.

You just need to press the **[EXECUTE]** button to load the file.

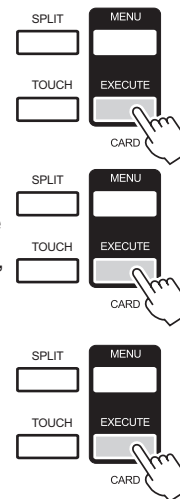

LoadSty

F STY_0001

00 ! UserSty

00 ! Sure?

00 ! Wait...!

3 Load Memory

Select the menu "LoadMem" and press the **[EXECUTE]** button, the memory files you saved or directory in the root of SD are displayed on the LCD, the main name of the file includes 8 characters, the postfix name is MEM.

Press the **[EXECUTE]** button, "Sure?" will be displayed on the LCD.

You just need to press the **[EXECUTE]** button to load the file.

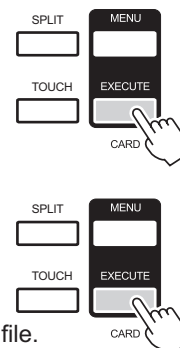

LoadMem

F MEM_0001

F Sure?

F Wait...!

Save

Select the menu "Save" and press the [EXECUTE] button, the Save menu are displayed on the LCD, it includes "SaveSong", "SaveSty" and "SaveMem".

You can select either with DIAL or the [+ / YES] and the [- / NO] button

The operation of SAVE is same as PLAY. If there is no any subdirectory or recognized files in the storage directory you select, "." will displayed on LCD, and you are allowed to use [+ / YES]; [- / NO] button or DIAL to change to "SaveHere". When "SaveHere" displayed on the LCD, press [EXECUTE] to save the file to the current directory.

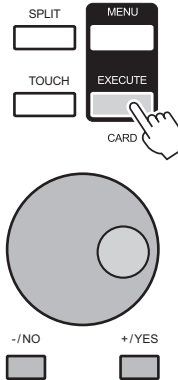

1 Save Song

Select the menu "SaveSong" and press the [EXECUTE] button, the user song recorded is displayed on the LCD. Select a user song to be saved with DIAL or the [+ / YES], [- / NO] button.

Press the [EXECUTE] button to go to next step, you can select the storage directory with DIAL or the [+ / YES], [- / NO] button.

Press the [EXECUTE] button to enter next step, LCD will display the naming state, you can play the keyboard to input the file name.

Press the [EXECUTE] button to enter the enquiry page, "Sure?" will be displayed on the LCD.

You just need to press the [EXECUTE] button to save the file.

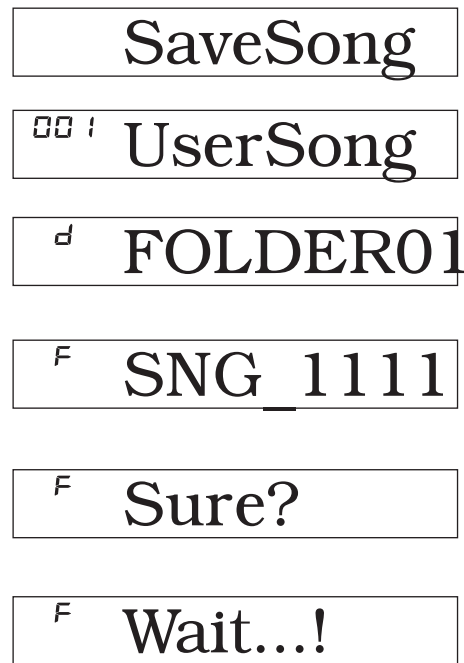
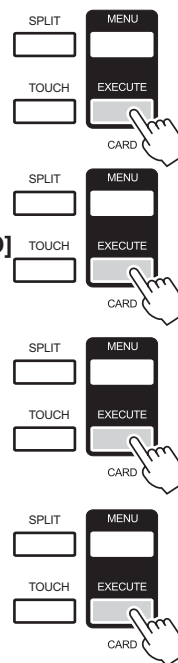

2 Save Style

Select the menu "SaveSty" and press the [EXECUTE] button, the user style recorded is displayed on the LCD. Select a user style be saved with DIAL or the [+ / YES], [- / NO] button.

Press the [EXECUTE] button to go to next step. Select the storage directory with DIAL or the [+ / YES], [- / NO] button.

Press the [EXECUTE] button to enter next step, LCD will display the naming state, you can play the keyboard to input the filename.

Press the [EXECUTE] button to enter the enquiry page, "Sure?" will be displayed on the LCD.

You just need to press the [EXECUTE] button to save the file.

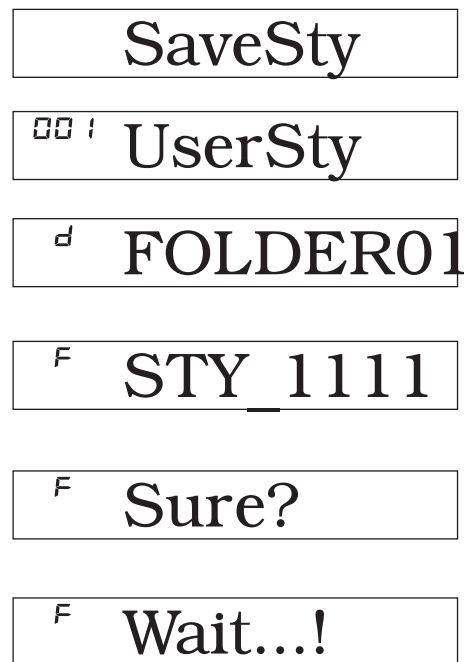
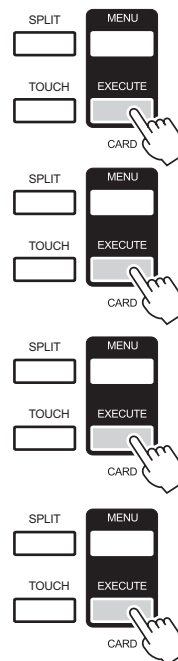

3 Save Memory

Select the menu "SaveMem" and press the **[EXECUTE]** button, you can select the storage directory with **DIAL** or the **[+/YES]** , **[-/NO]** button.

Press the **[EXECUTE]** button to enter next step, LCD will display the naming state, you can play the keyboard to input the filename.

Press the **[EXECUTE]** button to enter the enquiry page, "Sure?" will be displayed on the LCD.

You just need to press the **[EXECUTE]** button to save all the datas includes 48 memorizers.

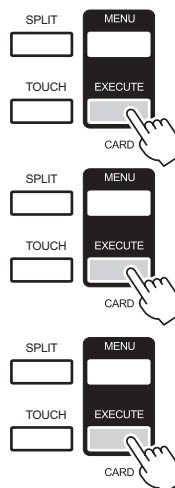

SaveMem

d FOLDER01

F MEM_1111

F Sure?

F Wait...!

Delete

Select the menu "Delete" and press the **[EXECUTE]** button, all files includes MIDI files, user songs and user styles or all directories in the root of SD are displayed on the LCD. You can select the file that need to be deleted with **DIAL** or the **[+/YES]** & the **[-/NO]** button.

Press the **[EXECUTE]** button, "Sure?" will be displayed on the LCD.

You just need to press the **[EXECUTE]** button to delete the file.

NOTE

- The directorids is unable to delete.

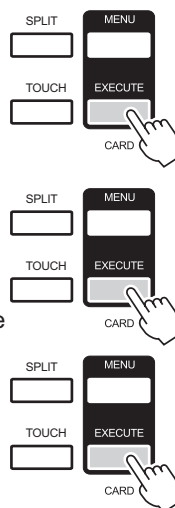

Delete

F Sty_0001

F Sure?

F Wait...!

Format

Select the menu "Format" and press the **[EXECUTE]** button, "Sure?" will be displayed on the LCD.

Press the **[EXECUTE]** button to format it, the card will be formatted.

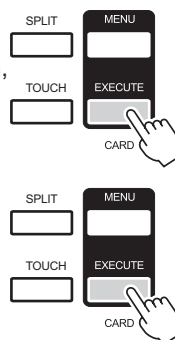

Format

F Sure?

F Wait...!

SD Function

The file name includes 1-8 characters which can be inputted with the keyboard.

Keyboard & ASCII Character Relative Table is as follows:

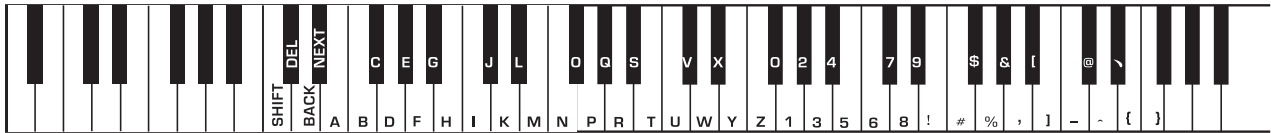

Explanation:

[SHIFT]:

26 letters will be displayed with capital letter by pressing the keyboard in letter area directly.

[DELETE]:

To erase the character which cursor flashes.

[BACK]:

move the current cursor to the left.

[NEXT]:

move the current cursor to the right.

NOTE

- While in the SD mode, press the [SHIFT] key hold on, it won't respond to it.
- If the name input has already existed, LCD will display "SameName" temporarily, then exit the SD mode to return the previous state.
- If there's no enough space in the card after name input, LCD will display "CardFull" temporarily, then exit the SD mode to return the previous state.

SameName

CardFull

MIDI Function

What is MIDI

- 1 MIDI stands for "Musical Instrument Digital Interface", that is the standard interface between a PC and other electronic instrument(s).
- 2 USB connection can be used for midi data transference with computer or other USB host devices that support USB audio device with an USB cable.
- 3 The keyboard can be connected to the PC or other USB host device with an USB interface.
- 4 Use the keyboard as a tone generator, the data (MIDI) recorded on the PC or other USB host devices can be played on the keyboard.

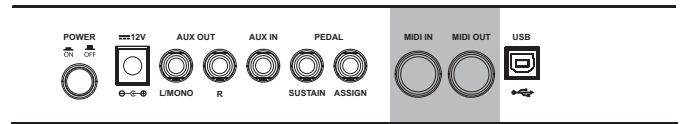

NOTE

- While a recording is playing back and a style is playing, you can not use the MIDI IN function, or the song you are playing will have error occurs for the same channel.

USB Connection

1 System Requirements

- CPU: 300 MHz or higher, Pentium 2
- Memory: 64MB or more
- Hard Disk: at least 2 MB of free base
- OS: WINDOWS 2000/XP

2 The Method of Connection

Connect a standard USB cable between the rear-panel of the USB jack of the instrument and the USB jack on your computer (USB cable sold separately).

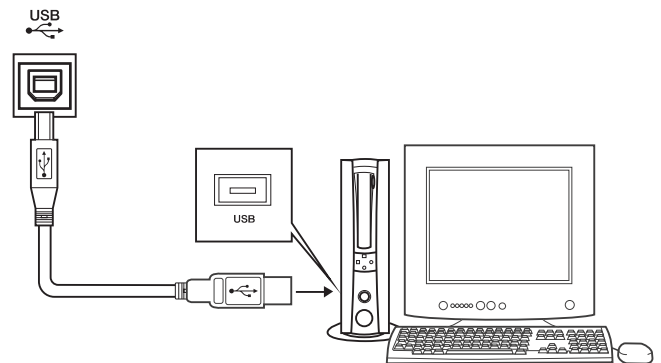

3 USB Precautions

Please observe the following precautions when connecting the instrument to a computer via a USB cable. Failure to do so can cause the instrument and/or the computer to hang up (freeze), possibly causing corruption or losing the data.

If the instrument or computer does hang up, turn the power of both devices off and then turn it on again after a few seconds.

NOTE

- Activate the computer from a sleep/suspended/standby mode before connecting the USB cable.
- Connect the USB cable to the instrument and a computer before turning the power of the instrument on.

MIDI Connection

1 Connection rule

In midi connection, the equipment which control another one is called "Host equipment", while another is called "Affiliated equipment".

The host equipment's MIDI OUT connects with affiliated equipment's MIDI IN

Note that MIDI OUT cannot be connected with MIDI IN on the same equipment.

2 The method of connection

Connect the MIDI interface with PC.

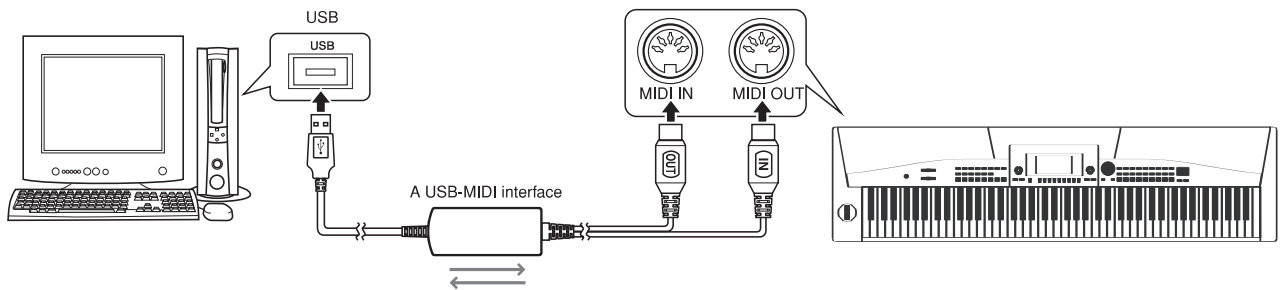

Connect the MIDI interface with the other MIDI interface.

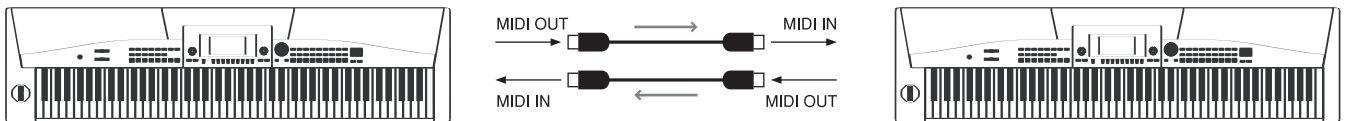

MIDI Application

The keyboard can control other equipments or electronic instruments.

Some equipments can be used to control the keyboard.

PC recorded data (MIDI) can be played on the keyboard.

Specifications

LCD display	Multi-functional LCD
Keys	88 hammer action key
Polyphony	64-note polyphony(max)
Voice	559 Voices
Style	203 Styles, including 3 user styles.
Song	100 Songs
Demo	2 Demos
Control button	Power on/off, Volume, Brilliance, Accomp +/-, Tempo +/-, Lesson, L&R, Chord Dictionary, Mixer, Function Back/Next, Voice, Style, Song, O.T.S. , M1-M6, Store, Bank, Start/Stop ►■, Sync Start ■■, Sync Stop, Intro/End/Repeat A/B, A ◀◀, B ▶▶, FADE, Chord mode, Record, Style Record, Play/Stop, Accomp, Melody 1, Melody 2, Melody 3, Melody 4, Melody 5, Dual, Split, Touch, DSP, Demo, SD Menu, Execute, +/YES, -/NO, Dial, Piano, Metronome, Tranpose +/-
Accompaniment Control	Start/Stop ►■, Sync Start ■■, Sync Stop, Intro/End/Repeat A/B, A ◀◀, B ▶▶, FADE,
Record Function	Record, Style Record, Play/Stop, Accomp, Melody 1, Melody 2, Melody 3, Melody 4, Melody 5
Panel Memory	48 Memory Storage
Connectors	DC Power, Headphones, Aux.Out (L/MONO R), Aux. IN, Sustain pedal, Soft pedal, USB, MIDI IN/OUT
Speaker	4 ₁ 15w x 2 ; 4 ₁ 25w x 2
Dimension	1360(L)x370(W)x143(H)mm
Weight	19.5kg
Accessories	Adaptor, Music Rest, Manual

* All specifications and appearances are subject to change without notice.

Trouble Shooting

Problem	Possible Cause and Solution
No matter the instrument is turned on or off, a popping sound will be temporarily produced.	This is normal and indicates that the instrument is receiving electrical power.
There is no sound even when the keyboard is played or when a song or style is being played.	Check if any cable or headphone is connected to the PHONES jack on the rear panel. When a set of headphones is plugged into this jack, no sound is output.

Appendix 1-Voice List

No	Name
Piano	
001	Stereo Grand Piano 1
002	Stereo Grand Piano 2
003	Stereo Grand Piano / W
004	Grand Piano / W
005	Stereo Piano Dark
006	Octave Piano 1
007	Octave Piano 2
008	Synth Piano
009	Dreamscape
010	Piano & Strings
011	Piano & Choir
012	Acoustic Grand Piano
013	Stereo Bright Piano
014	Bright Piano 1
015	Bright Piano 2
016	Bright Piano 1 / W
017	Bright Piano 2 / W
018	Detuned Piano
019	Chorus Piano
020	Velocity Crossfade Piano
021	Piano Pad
022	Piano & Vibraphone
023	Electric Grand Piano
024	Stereo Honk-Tonk
025	Honky-Tonk
026	Honky-Tonk Dark
027	Honky-Tonk 1 / W
028	Honky-Tonk 2 / W
029	Stereo Hard E.P.
030	Detuned E.P. 1
031	Detuned E.P. 2
032	E Piano 1
033	E Piano 2
034	E.Piano 1 / W
035	E.Piano 2 / W
036	E.Piano 3 / W
037	E.Piano 4 / W
038	Hard E.P.
039	Soft E.P.
040	Deep E.P.
041	Velocity Crossfade E.P. 1

042	Velocity Crossfade E.P. 2
043	Layered E.P. 1
044	Layered E.P. 2
045	Nylon E.P.
046	Warm E.P.
047	Cloudy E.P.
048	Grand Harpsichord
049	Harpsichord 1
050	Harpsichord 2
051	Harpsichord 1 / W
052	Harpsichord 2 / W
053	Harpsichord Octave 1
054	Harpsichord Octave 2
055	Harpsichord Release
056	Harpsikd / O
057	Piano & Harpschord
058	Stereo Clavichord
059	Clavichord 1
060	Clavichord 2
061	Clavichord 1 / W
062	Clavichord 2 / W
063	Clavichord Wah
064	Punchy Clavichord
Mallet	
065	Celesta 1
066	Celesta 2
067	Birght Celeasta
068	Celesta & Sine
069	Reecho Bell
070	Celesta & Music Box
071	Glockenspiel 1
072	Glockenspiel 2
073	Glockenspiel & Sine
074	Glockenspiel & Celesta
075	Music Box 1
076	Music Box 2
077	Music Box 3
078	Toy Box
079	Music Box & Harp
080	Stereo Vibrapho
081	Rigid Vibraphone
082	Vibraphone 1
083	Vibraphone 2

No	Name
084	Vibraphone 1 / W
085	Vibraphone 2 / W
086	Vibraphone & Bell
087	Vibraphone & Harpsichord
088	Marimba 1
089	Marimba 2
090	Marimba / W
091	SinMarimba
092	Stereo Marimba
093	Marimba & Vibraphone
094	Wood Drum
095	Xylophone 1
096	Xylophone 2
097	Tubular Bells 1
098	Tubular Bells 2
099	Tubular Bells 3
100	Dulcimer
101	Santur
102	Shorty
Organ	
103	Drawbar Organ Stereo
104	Soft Stereo Drawbar Organ
105	Mellow Drawbar Organ
106	Drawbar Organ
107	Drawbar Organ Detuned
108	Bright Drawbar Organ
109	1960 Drawbar Organ
110	1970 Percussive Organ
111	Percussive Organ 1
112	Percussive Organ 2
113	Light Click Organ
114	Percussive Organ Detuned
115	Stereo Rotary Organ
116	Rock Organ
117	Rotary Organ
118	Slow Rotary Organ
119	Detuned Church Organ
120	Church Organ 1
121	Church Organ 2
122	Octave Church Organ
123	Stereo Reed Organ
124	Reed Organ
125	Accordion 1

Appendix 1- Voice List

No	Name
126	Accordion 2
127	Accordion 3
128	Chorus Accordion
129	Mustte
130	Accord ItSolo
131	Harmonica 1
132	Harmonica 2
133	Detuned Harmonica
134	Sweet Harmonica
135	Tango Accordion
Guitar	
136	Nylon G.T. 1
137	Nylon G.T. 2
138	Nylon G.T. / R
139	Velocity Nylon G.T.
140	Detuned Nylon G.T.
141	Chorus Nylon G.T.
142	Bright Nylon G.T.
143	Steel G.T. 1
144	Steel G.T. 2
145	Detuned StebG.T.
146	Velocity Steel G.T.
147	Velocity Steel G.T.(Fx)
148	Pedal Steel G.T.
149	Velocity Pedal Steel G.T.
150	12 String GT.
151	Chorus Steel G.T.
152	Nylon & Steel G.T.
153	Jazz G.T. 1
154	Jazz G.T. 2
155	Mellow G.T.
156	Velocity Jazz G.T.
157	Jazz G.T. Detuned
158	Clean G.T. 1
159	Clean G.T. 2
160	Clean G.T. 3
161	Stereo Clean G.T.
162	Velocity Clean G.T.
163	Chorus Clean G.T.
164	Muted G.T. 1
165	Muted G.T. 2
166	Funk G.T.
167	Jazz Boy

No	Name
168	Stereo Muted G.T.
169	OverDriven G.T. 1
170	OverDriven G.T. 2
171	Detuned Overdriven G.T.
172	Distortion G.T. 1
173	Distorted G.T. 2
174	FeedbackG.T. 1
175	FeedbackG.T. 2
176	Distorted Rhythm G.T.
177	5th Distortion
178	Distortion G.T. Octave
179	Stereo Distorted G.T.
180	G.T. Harmonics 1
181	G.T. Harmonics 2
Bass	
182	Acoustic Bass 1
183	Acoustic Bass 2
184	Acoustic Bass Detuned
185	Acoustic Bass Filter
186	Jazz Style
187	A.Bass & Mute G.T.
188	Resonant Bass
189	Velocity Crossfade Bass
190	Wah Bass 1
191	Wah Bass 2
192	Finger Bass 1
193	Finger Bass 2
194	Detuned Finger Bass
195	Dark Finger Bass
196	Jazz Bass
197	Resonant Finger Bass
198	Velocity Bass
199	Velocity Finger Bass (FX)
200	Bass & Distorted Elec Guitar
201	Pick Bass 1
202	Pick Bass 2
203	Mute Pick Bass
204	Detuned Pick bass
205	Fretless Bass 1
206	Fretless Bass 2
207	1990 Bass
208	Fretless Bass & Sine
209	Fretless Bass Detuned 1

No	Name
210	Fretless Bass Detuned 2
211	Fretless Bass Detuned 3
212	Slap Bass 1
213	Slap Bass 2
214	Slap Bass 3
215	Slap Bass 4
216	Power Slap Bass
217	Lash Thumb Bass
218	Resonant Slap Bass
219	Velocity Switch Slap Bass
220	Synth Bass 1
221	Synth Bass 2
222	Synth Bass 3
223	Synth Bass 4
224	Synth Bass 5
225	Super Synth Bass
226	Tech Synth Bass
227	Synth Bass / O
228	Fast Syntonic Bass
Strings	
229	The ViOlin
230	Violin 1
231	Violin 2
232	Violin 3
233	Mono Violin
234	Octave Violin
235	Electric Violin
236	Slow Violin
237	Two Violin
238	Soft Violin
239	Largo Violin
240	Viola 1
241	Viola 2
242	Viola 3
243	Dark Viola
244	Cello 1
245	Cello 2
246	Cello 3
247	Cello 4
248	Celloen 16'
249	Chamber Music
250	Contrabass 1
251	Contrabass 2

No	Name
252	Tremolo Strings 1
253	Tremolo Strings 2
254	Slow Tremolo Strings 1
255	Slow Tremolo Strings 2
256	Pizzicato Strings 1
257	Pizzicato Strings 2
258	Octave Pizzicato
259	Orchestral Harp 1
260	Orchestral Harp 2
261	Velocity City
262	Africa
263	Timpani 1
264	Timpani 2
Strings Ensembl	
265	The Strings
266	Synth Strings 1
267	Synth Strings 2
268	Synth Strings 3
269	Synth Strings 4
270	Synth Strings 5
271	Strings Ensemble 1
272	Strings Ensemble 2
273	Resonant Strings
274	Stereo Slow Strings
275	Slow Strings
276	Sforzato Strings
277	Orchestra
278	Legato Strings
279	Arco Strings
280	1960 Strings
281	1970 Strings
282	Solo Strings
283	Choir Aahs 1
284	Choir Aahs 2
285	Choir Aahs 3
286	Mellow Choir
287	Stereo Choir Aahs 1
288	Stereo Choir Aahs 2
289	Strings Choir
290	Voice Oohs 1
291	Voice Oohs 2
292	Synth Voice 1
293	Synth Voice 2

No	Name
294	Echo Synth Voice
295	Orchestra Hit 1
296	Orchestra Hit 2
297	Orchestra Hit Octave
298	Orchestra Hit Stereo
299	6th Orchestra Hit
Brass	
300	Trumpet 1
301	Trumpet 2
302	Trumpet 3
303	Dark Trumpet
304	Resonant Trumpet
305	Sweet Trumpet
306	Wah Trumpet
307	Trombone 1
308	Trombone 2
309	Trombone 3
310	Dark Trombone
311	Strings & Trombone
312	Tuba 1
313	Tuba 2
314	Tuba Solo
315	Soft Tuba
316	Muted Trumpet 1
317	Muted Trumpet 2
318	French Horn 1
319	French Horn 2
320	Soft Horn
321	Stereo French Horn
322	5th Horn Orchestr
323	Brass Section 1
324	Brass Section 2
325	Brass Section 3
326	Brass Section 4
327	Brass Section Octave
328	Brass Swell
329	Brassband
330	Bright Brass Section
331	Dark Brass
332	Mute Brass Ensemble
333	Sforzato Brass
334	Stereo Brass & Strings
335	Synth Brass 1

No	Name
336	Synth Brass 2
337	Synth Brass 3
338	Synth Brass 4
339	Synth Brass 5
340	Leap Brass
341	Octave Synth Brass
342	Synth Brass & Strings 1
343	Synth Brass & Strings 2
344	Echo Brass
345	Sooth Brass
Reed	
346	Soprano Sax 1
347	Soprano Sax 2
348	Soprano Sax Soft
349	Solw Soprano Sax
350	Sweet Soprano Sax
351	Alto Sax
352	Alto Sax & Breath
353	Super Alto Sax
354	Sax Band
355	Folk Sax
356	Tenor Sax
357	Baritone Sax
358	Baritone Sax & Breath
359	Oboe 1
360	Oboe 2
361	Sweet Oboe
362	English Horn 1
363	English Horn 2
364	Analog Horns
365	Woodwinds
366	Bassoon 1
367	Bassoon 2
368	Clarinet 1
369	Clarinet 2
Pipe	
370	Piccolo
371	Flute
372	Jazz Flute
373	Recorder
374	Sweet Pan Flute
375	Pan Flute
376	Dark Pan Flute

Appendix 1- Voice List

No	Name
377	Blown Bottle
378	Shakuhachi
379	Whistle 1
380	Whistle 2
381	Ocarina
Lead	
382	Lead 1 (square)
383	Square
384	Lead Sine
385	Slow Square Lead
386	Sine Solo
387	Square Lead 1
388	Square Lead 2
389	Thick Square
390	Corrie
391	Quint
392	2 Oscillators Lead
393	Sawtooth Lead 1
394	Sawtooth Lead 2
395	Wavy Sawtooth
396	Lead 2 (sawtooth)
397	Solw Saw
398	Super Analog
399	Synther
400	Heavy Sawtooth
401	Bauble Lead
402	PWM 4th
403	Lead 3 (calliope)
404	Lead 4 (chiff)
405	Lead 5 (charang)
406	Lead 6 (voice)
407	Voice Lead
408	Lead 7 (fifths)
409	Fifths Lead Soft
410	Fifth Lead
411	Lead 8 (Bass & Lead)
412	Massiness
413	Bass Lead
Pad	
414	Pad 1 (newage)
415	Slow Square
416	New Year Pad
417	Pad2 (warm)

No	Name
418	PWM Pad
419	Sine Pad
420	Warmly Pad
421	Horn Pad
422	Pad 3 (Polysynth)
423	Click Pad
424	Analog Pad
425	Poly Pad
426	Poly Synth Pad
427	Pad 4 (choir)
428	Choir Pad 2
429	Pad 5 (bowed)
430	Bowed Pad 2
431	Pad 6 (metallic)
432	Metallic Pad 2
433	Pan Pad
434	Pad 7 (halo)
435	Halo Pad 2
436	Pad 8 (sweep)
437	Sweep Pad 2
438	Dipolar Pad
439	Rising
440	Congregate
Effects	
441	FX1 (rain)
442	FX2 (soundtrack)
443	Progenitor
444	Prelude
445	FX3 (crystal)
446	FX4 (atmsphere)
447	Warm Air
448	FX5 (brightness)
449	Smog
450	FX6 (goblins)
451	Choir Bell
452	FX7 (echoes)
453	Reecho Pan
454	Large Pan
455	Echordrzz Slow
456	Fantasyland
457	FX8 (sci-fi)
Ethnic	

No	Name
458	Sitar
459	Detuned Sitar
460	Banjo
461	Shamisen
462	Koto
463	Kalimba
464	Bagpipe
465	Fiddle
466	Shanai
Percussive	
467	Tinkle Bell
468	Agogo
469	Steel Drums
470	Wood Block
471	Taiko Drum
472	Melodic Tom
473	Synth Drum
474	Reverse Cymbal
Sound Effects	
475	Guitar Fret Noise
476	Breath Noise 1
477	Stream
478	Helicopter 2
479	Seashore 1
480	Telephone Ring 2
481	OpenDoor
482	Starship
483	CloseDoor
484	Siren
485	Gunshot 2
486	Rise2
487	Bird Tweet
488	Ambulance
489	Rise1
490	Fall
491	Seashore 2
492	Bird 1
493	Clop
494	Wind
495	Cattle
496	Horse
497	Telephone Ring 1
498	Bird

No	Name
499	Breath Noise 2
500	Heartbeat
501	Laugh
502	Applause 2
503	Helicopter 1
504	Fire
505	Punch
506	ScratchCut
507	Fight 1
508	Shot
509	Fight 2
510	Applause 1
511	Sheep
512	Firework
513	Lion
514	Frog
515	Bird 2
516	Dog
517	Spring
518	Gunshot 1
519	Gunshot 3
520	Laser Gun
521	Drip
522	Siren 2
Combined Voice	
523	Stereo Piano & Strings Pad
524	Stereo Piano & Choir
525	Piano & Warm Pad
526	FM Electric Piano
527	Old Electric Piano
528	Digital Piano
529	E.Piano & Strings
530	Harpsichord & Stereo Strings
531	Digital Music Box
532	Serenity
533	Vibraphone & Stereo Strings
534	FM Tubular Bells
535	Organ & Stereo Strings
536	Stereo Organ & Piano
537	Accordian 2
538	Power Distorted Guitar
539	Dynamic Bass
540	X Fade Bass

No	Name
541	Stereo Strings & Piano
542	Orchestra
543	Full Strings 1
544	Full Strings 2
545	Symphonic
546	Stereo Choir & Strings
547	Trombone & Stereo Strings
548	Club Brass
549	Woodwinds & Strings
550	Pan Flute & Strings Pad
	Drum Set
551	Standard Kit
552	Room Kit
553	Power Kit
554	Electronic Kit
555	Analog Kit
556	Jazz Kit
557	Brush Kit
558	Orchestra Kit
559	SFX Kit

Appendix 2- Style List

Number	Name
8BEAT	
001	8 Beat Rock
002	Guitar Pop 1
003	8 Beat 1
004	Sweet Beat
005	8 Beat Dance
006	8 Beat Disco
007	Pop Funk
008	8 Beat 2
009	60's 8 Beat
010	Rhythm & Beat
011	Miami Beat
16BEAT	
012	16 Beat 1
013	Pop 16 Beat 1
014	Pop 16 Beat 2
015	Modern 16 Beat
016	16 Beat Hot
017	16 Beat Modern
018	16 Beat Funk
019	16 Beat 2
020	Cool Beat
021	16 Beat Ballad
022	16 Beat 3
023	Pop Shfl
024	Guitar Funk
025	16 Beat Funk 1
POP	
026	6/8 Pop
027	Brit. Pop 1
028	Brit. Pop 2
029	Pop Hit
030	Fusion Shuffle
031	Analog Night
032	Guitar Pop 2
033	Popbeat
034	Soft Beat
035	60's Pop
036	Sting Latin
BALLAD	
037	Soft Ballad

Number	Name
038	Natural Ballad
039	Love Ballad
040	Easy Ballad
041	Slow Ballad
042	Folk Ballad
043	Pop Ballad 1
044	Pop Ballad 2
045	EP Ballad
046	New R&B Ballad
ROCK	
047	Slow Rock
048	70's Rock & Roll
049	FolkRock
050	Soft Rock
051	Pop Rock
052	Old Rock
053	Easy Rock
054	New Shuffle
055	Rock Hip Hop
056	Rock & Roll
057	Rock1
058	RockShuffle
059	R'N'R 1
060	Rock Shuffle
BALLROOM	
061	Twist1
062	Twist2
063	Big Band Fox 1
064	Tango
065	Slow Fox 1
066	Slow Waltz 1
067	Swing Fox
068	Salsa 2
069	Cha Cha 1
070	Cha Cha 2
071	Beguine1
072	Beguine2
073	Rhumba 1
074	Samba 1
075	Samba2
076	Jive
077	Foxtrot

Number	Name
078	Quick Step
DANCE	
079	Down Beat
080	Techno
081	Progressive
082	Rap 1
083	Rap 2
084	Disco
085	Soft Disco
086	Disco Party
087	70's Disco
088	70's Disco Funk
089	Clubdance
090	Euro Dance
091	80's Dance
092	Hip Hop
093	Garage
SOUL & FUNK	
094	Jay R&B
095	Gospel Swing
096	Gospel
097	Funk
098	Electric Funk
099	Groove Funk
100	Rubber Funk
101	Cool Funky
102	Jazz Funk
103	Groove
104	Soul
105	Hip Hop Soul
106	Hip Hop Beat
107	R & B
108	Soul Beat
109	R & B Ballad
110	British Soul Pop
111	Samba Funk
SWING&JAZZ	
112	Swing1
113	Swing2
114	Jazz Brush
115	Latin Jazz
116	Fusion

Appendix 2- Style List

Number	Name
117	Acid Jazz
118	Cool Jazz Ballad
119	Swing Shuffle
120	Big Band 40's
121	Big Band Medium
122	Dixieland
123	Acoustic Jazz
124	Guitar Swing
125	Ragtime
126	Modern Jazz Ballad
127	Swing Ballad
128	Big Band Ballad
129	Orchestra Swing
COUNTRY	
130	Bluegrass
131	Country 8 Beat
132	Modern Country
133	Country Pop1
134	Country Pop2
135	2/4 Country
136	Country
137	Country Quick Steps
138	Country Rock
139	Country Folk
140	Country Shuffle
Latin/Latin Dance	
141	Bossa Nova 1
142	Latin
143	Bossa Nova2
144	New Reggae
145	Dance Reggae
146	Pasodoble
147	Lite Bossa
148	Latin Rock
149	Beguine
150	Slow Bolero
151	Disco Samba
152	Mambo
153	Meneito
154	Rumba1
155	Rumba2
156	Tikitikita

Number	Name
157	Lambada
158	Pop Cha Cha1
159	Pop Cha Cha2
160	Salsa
161	Bossa1
World	
162	EnkaBallad
163	Laendler
164	Hawaiian
165	Sirtake
166	Venezia
167	6/8 Flipper
168	New Age
169	Tarantella
170	Scottish
171	Norteno
Waltz	
172	Waltz
173	Old Waltz
174	English Waltz
175	French Waltz
176	German Waltz
177	Italian Mazurka
178	MariachWaltz
179	ViennaWaltz 1
180	Slow Waltz 2
181	ViennaWaltz 2
182	Slow Waltz 1
183	Jazz Waltz
TRADITIONAL	
184	Polka
185	6/8 March
186	German Polka
187	Party Polka
188	March

Number	Name
189	Polka2
190	US March
191	Musette
192	French Musette
193	Mazurke
194	1-Mar
ORIENTAL	
195	Dangdut1
196	Dangdut2
197	Dangdut3
198	Dangdut4
199	Dangdut5
200	Dangdut6
USER STYLE	
201	Style 1
202	Style 2
203	Style 3

Appendix 3-Song List

Number	Name
PIANO	
001	Moseta Dance
002	Brave Cavalier
003	Four Little Swans
004	Habanera
005	Turkish March
006	Aria
007	Away In A Manger
008	Wedding March
009	Jesus, Save My Soul
010	America The Beautiful
CLASSICAL	
011	Carmen-Entractell
012	Annen Polka
013	Pianosonatan 08 IN Cm IN Pathetique
014	Brahms Waltz
015	Aida
016	Carmen-Prelude
017	L'Arlesienne
018	Ungarische Tanz
019	Mazurka
020	Menuett
021	Musical Moments
022	Pizzicato Polka
023	Rigoletto
024	Serenade
025	Song Without Words
026	Swan
027	Prelude To Act 2 (Swan Lake)
028	Valse (Swan lake)
029	The Happy Farmer
030	The Sleeping Beauty
031	La Traviata
032	Wiegenlied
033	Mov.2 Adagio Non Troppo Piano Sonata No.9 In D
034	Mov.1 Andante Grazioso Piano Sonata No.11 In A [Alla Tur Sonata 11ca]
035	Prelude In C
036	Chinese Dance
037	Emperors Waltz
038	March Militaire
039	Symphony No.40
040	Auf Flugeln Dec Gesanges
041	Arpeggione Sonata in Am

FOLK & COUNTRY	
042	Santa Lucia
043	Country
044	Jambalaya
045	Susanna
046	Bridge
047	Battle Hymne Of The Republic
048	The Old Gray Mare
049	American Patrol
050	In The Rain
051	Sippin' Cider Through A Straw
GOLDEN & POP	
052	On London Bridge
053	Are You Lonesome Tonight
054	Only You
055	End Of The World
056	House Of Rising Sun
057	Solveig's Song
058	The Blue-Bells Of Scotland
059	Over The Rainbow
060	Beautiful Dreamer
061	It's Been A Long Long Time
062	Edelweiss
063	O Sole Mio
064	Der Deitcher's Dog
065	Joy To The World
066	Silent Night
067	Ave Maria
068	Five Hundred Miles
069	Happy New Year
070	It's Beginning To Look A Lot Like Christmas
071	Jeanie With The Light Brown Hair
072	My Bonnie
073	Song Of The Pearlfisher
074	Summer Palace
075	The StageCoach
076	Entertainer
077	Annie Laurie
078	Killing Me Softly With His Song
079	Love Is Blue
080	Last Rose Of Summer
081	The Old King Cole

Appendix 3- Song List

Number	Name
	JAZZ & FUSION
082	Little Brown Jug
083	Maple Leaf Rag
084	June Samba
085	Funk
086	I Can.....
087	Sea Shore
088	Guitar&Saxphone
089	The Hip Hop' S Night
090	Blue Lunch
091	Cobweb
092	Wine
093	Jazz Old Man
094	Dark Eyes
095	Carlos
096	Sad
097	The Jazz
	ORIENTAL
098	South Mud Bay
099	Give You A Rose
100	Flowing Rill

Appendix 4-Demo List

Number	Name
001	Jazz
002	Dream of freedom

Appendix 5- Chord List

	Chord Name[Abbreviation]	Normal Voicing	Chord	Display
0	Major[M]	1-3-5	C	C
1	Major sixth[6]	1-(3)-5-6	C6	C6
2	Major seventh[M7]	1-3-(5)-7	CM7	CM7
3	Major seventh sharp Eleventh[M7#11]	1-(2)-3-#4-(5)-7	CM7#11	CM7(#11)
4	Major add ninth[Madd9]	1-2-3-5	CMadd9	CM(9)
5	Major ninth[M9]	1-2-3-(5)-7	CM9	CM7(9)
6	Major sixth add ninth[6 9]	1-2-3-(5)-6	C6 9	C6(9)
7	augmented[aug]	1-3-#5	Caug	Caug
8	Minor[m]	1-b3-5	Cm	Cm
9	Minor sixth[m6]	1-b3-5-6	Cm6	Cm6
10	Minor Seventh[m7]	1-b3-(5)-b7	Cm7	Cm7
11	Minor seventh flatted fifth[m7b5]	1-b3-b5-b7	Cm7b5	Cm7(b5)
12	Minor add ninth[madd9]	1-2-b3-5	Cmadd9	Cm(9)
13	Minor ninth[m9]	1-2-b3-(5)-b7	Cm9	Cm7(9)
14	Minor eleventh[m11]	1-(2)-b3-4-5-(b7)	Cm11	Cm7(11)
15	Minor major ninth[mM7]	1-b3-(5)-7	CmM7	CmM7
16	Minor major ninth[mM9]	1-2-b3-(5)-7	CmM9	CmM7(9)
17	Diminished[dim]	1-b3-b5	Cdim	Cdim
18	Diminished seventh[dim7]	1-b3-b5-6	Cdim7	Cdim7
19	Seventh[7]	1-3-(5)-b7	C7	C7
20	Seventh suspended Fourth[7sus4]	1-4-5-b7	C7sus4	C7sus4
21	Seventh flatted Fifth[7b5]	1-3-b5-b7	C7b5	C7(b5)
22	Seventh Ninth[79]	1-2-3-(5)-b7	C7 9	C7(9)
23	Seventh sharp eleventh[7#11]	1-2-3-#4-(5)-b7or 1-(2)-3-#4-5-b7	C7#11	C7(#11)
24	Seventh thirteenth[7 13]	1-3-(5)-6-b7or 2-3-5-6-b7	C7 13	C7(13)
25	Seventh flatted Ninth[7b9]	1-b2-3-(5)-b7	C7b9	C7(b9)
26	Seventh flatted Thirteenth[7b13]	1-3-5-b6-b7	C7b13	C7(b13)
27	Seventh Sharp ninth[7#9]	(1)-#2-3-(5)-b7	C7#9	C7(#9)
28	Major Seventh augmented[M7aug]	1-3-#5-7	CM7aug	CM7aug
29	Seventh augmented[7aug]	(1)-3-#5-b7	C7aug	C7aug
30	Suspended Fourth[sus4]	1-4-5	Csus4	Csus4
31	One plus two plus five[1+2+5]	1-2-5	C1+2+5	C

Appendix 6- MIDI Implementation Chart

Function		Transmitted	Recognized	Remarks
Basic Channel	Default	1ch	ALL	
	Changed	1-16ch	1-16ch	
Mode	Default	◦	3	
	Messages	◦	3	
	Altered	*****	◦	
Note Number ↓		0-127	0-127	
	True voice	*****	0-127	
Velocity:	Note on	↗ 9nH,V=1-127	↗ 9nH,V=1-127	
	Note off	◦ ↓ 9nH,V=0 ↓	◦ (9nH,V=0; 8nH,V=0-127)	
After Touch	Keys	◦	◦	
	Chs	◦	◦	
PitchBend		↗	↗	
Control Change	0	◦	◦	Bank Select
	1	◦	◦	Modulation
	5	◦	◦	Portamento Time
	6	◦	◦	Data Entry
	7	◦	◦	Volume
	10	◦	◦	Pan
	11	◦	◦	Expression
	64	◦	◦	Sustain Pedal
	65	◦	◦	Portamento ON/OFF
	66	◦	◦	Sostenuto Pedal
	67	◦	◦	Soft Pedal
	80	◦	◦	Reverb Program
	81	◦	◦	Chorus Program
	91	◦	◦	Reverb Level
	93	◦	◦	Chorus Level
120	◦	◦	All Sound Off	
121	◦	◦	Reset All Controllers	
123	◦	◦	All Notes Off	
Program Change	↓ True #	◦	◦	
		*****	0-127	
System Exclusive		◦	◦	
System	↓ Song Position	◦	◦	
	↓ Song Select	◦	◦	
	↓ Tune	◦	◦	
System Real Time	: Clock	◦	◦	
	↓ Commands	◦ *1	◦ *1	
Aux Messages	: Local on/off	◦	◦	
	: All Notes off	↗	↗	
	↓ Active sense	◦	↗	
	↓ Reset	◦	↗	
Note ↓		*1 When the accompaniment is started, an FAH message is transmitted. When accompaniment is stopped, an FCH message is transmitted. When an FAH message is received, accompaniment is started. When an FCH message is received, accompaniment is stopped.		

Mode 1: OMNI ON , POLY Mode 2 : OMNI ON , MONO ◦ : YES
 Mode 3: OMNI OFF , POLY Mode 4 : OMNI OFF , MONOX : NO

