

**th•mann**

DP-30  
digital piano



Musikhaus Thomann e.K.  
Treppendorf 30  
96138 Burgebrach  
Germany  
Telephone: +49 (0) 9546 9223-0  
E-mail: [info@thomann.de](mailto:info@thomann.de)  
Internet: [www.thomann.de](http://www.thomann.de)

17.08.2012

## Table of contents

<b>1</b>	<b>General notes</b> .....	<b>5</b>
<b>2</b>	<b>Safety notes</b> .....	<b>6</b>
<b>3</b>	<b>Features</b> .....	<b>8</b>
<b>4</b>	<b>Setup guide</b> .....	<b>9</b>
<b>5</b>	<b>Operating panel and connections</b> .....	<b>15</b>
<b>6</b>	<b>Connection options</b> .....	<b>17</b>
<b>7</b>	<b>Switching on / off and basic operation</b> .....	<b>18</b>
	7.1 Switching the digital piano on.....	18
	7.1.1 Switching on, volume control.....	18
	7.2 Song selecting.....	18
<b>8</b>	<b>Functions</b> .....	<b>19</b>
	8.1 Voices and effects.....	19
	8.1.1 Selecting voices.....	19
	8.1.2 Dual mode.....	19
	8.1.3 Split mode.....	20
	8.2 Style operation.....	20
	8.2.1 Selecting a style.....	20
	8.2.2 Accompaniment function.....	21
	8.2.3 Starting a style.....	22
	8.2.4 Fill A/B.....	23
	8.2.5 Ending a style.....	23
	8.2.6 Accompaniment volume.....	24
	8.2.7 Tempo.....	24
	8.2.8 Chord detection.....	24
	8.2.9 Metronome.....	27
	8.3 Function menu.....	27
	8.3.1 Transposing.....	28
	8.3.2 Fine tuning.....	29
	8.3.3 Beat.....	29
	8.3.4 Touch sensitivity.....	29
	8.3.5 Split point.....	30
	8.3.6 DSP effect level.....	30
	8.3.7 MIDI receive channel (Midi In).....	30
	8.3.8 MIDI send channel (Midi Out).....	31
	8.4 Mixer menu.....	31
	8.5 Memory.....	32
	8.5.1 Memory banks.....	32
	8.5.2 Memory data.....	32
	8.5.3 Storing & loading parameters.....	33
	8.5.4 Deleting memory data.....	33
	8.6 One Touch Setting.....	33

8.7	Recording and playback.....	34
8.7.1	Recording standby.....	34
8.7.2	Start recording.....	34
8.7.3	Stop recording.....	35
8.7.4	Recording playback.....	35
8.8	Songs for practising.....	36
<b>9</b>	<b>Voice list.....</b>	<b>37</b>
<b>10</b>	<b>Styles list.....</b>	<b>40</b>
<b>11</b>	<b>Practice and demo songs.....</b>	<b>42</b>
<b>12</b>	<b>Chord list.....</b>	<b>44</b>
<b>13</b>	<b>MIDI implementation chart.....</b>	<b>46</b>
<b>14</b>	<b>Technical specifications.....</b>	<b>48</b>
<b>15</b>	<b>Protecting the environment.....</b>	<b>49</b>



# 1 General notes

This user manual contains important information on safe operation of the device. Read and follow all safety notes and all instructions. Save this manual for future reference. Make sure that it is available to all persons using this device. If you sell the device, include the manual for the next owner.

Our products are subject to a process of continuous development. We therefore reserve the right to make changes without notice.

## Symbols and signal words

This section provides an overview of the symbols and signal words used in this user manual.

Signal word	Meaning
<b>DANGER!</b>	This combination of symbol and signal word indicates an immediate dangerous situation that will result in death or serious injury if it is not avoided.
<b>CAUTION!</b>	This combination of symbol and signal word indicates a possible dangerous situation that can result in minor injury if it is not avoided.
<b>NOTICE!</b>	This combination of symbol and signal word indicates a possible dangerous situation that can result in material and environmental damage if it is not avoided.
Warning signs	Type of danger
	Warning – high-voltage.
	Warning – danger zone.

## 2 Safety notes

### Intended use

This device is intended to be used for electronic sound generation using a piano keyboard. Use the device only as described in this user manual. Any other use or use under other operating conditions is considered to be improper and may result in personal injury or property damage. No liability will be assumed for damages resulting from improper use.

This device may be used only by persons with sufficient physical, sensorial, and intellectual abilities and having corresponding knowledge and experience. Other persons may use this device only if they are supervised or instructed by a person who is responsible for their safety.

### Safety



#### **DANGER!**

##### **Danger for children**

Ensure that plastic bags, packaging, etc. are disposed of properly and are not within reach of babies and young children. Choking hazard!

Ensure that children do not detach any small parts (e.g. knobs or the like) from the unit. They could swallow the pieces and choke!

Never let children unattended use electrical devices.



#### **DANGER!**

##### **Electric shock caused by short-circuit**

Always use proper ready-made insulated two-wire mains cabling (power cord). Do not modify the mains cable or the plug. Failure to do so could result in electric shock/death or fire. If in doubt, seek advice from a registered electrician.



#### **DANGER!**

##### **Electric shock caused by high voltages inside**

Within the device there are areas where high voltages may be present. Never remove any covers.

There are no user-serviceable parts inside.



#### **CAUTION!**

##### **Possible hearing damage**

With loudspeakers or headphones connected, the device can produce volume levels that may cause temporary or permanent hearing impairment.

Do not operate the device permanently at a high volume level. Decrease the volume level immediately if you experience ringing in your ears or hearing impairment.



**CAUTION!**

**Risk of injury due to heavy weight**

Due to the heavy weight of the device, at least two persons are required for transport and installation.



**NOTICE!**

**Operating conditions**

This device has been designed for indoor use only. To prevent damage, never expose the device to any liquid or moisture. Avoid direct sunlight, heavy dirt, and strong vibrations.



**NOTICE!**

**Power supply**

Before connecting the device, ensure that the input voltage (AC outlet) matches the voltage rating of the device and that the AC outlet is protected by a residual current circuit breaker. Failure to do so could result in damage to the device and possibly injure the user.

Unplug the device before electrical storms occur and when it is unused for long periods of time to reduce the risk of electric shock or fire.

### 3 Features

Special features of the digital piano:

- Keyboard: 88 weighted keys with hammer action, touch velocity in three steps.
- Multifunctional LCD.
- User friendly controls or [+/-] buttons to select styles, practise songs and voices.
- 210 voices. 16 voices can be selected directly.
- 120 styles. 12 Styles can be selected directly.
- 60 practise songs.
- Three demo songs.
- Single chord and fingered chord detection.
- Recording function.
- Four memory banks with four slots each.
- Style control buttons: [SYNC], [START/STOP], [FILL A], [FILL B], [INTRO/ENDING].
- Mixer for volume control of drums, bass, orchestra, first right hand voice, second right hand voice, left hand voice.
- Further operation and display elements: DUAL, SPLIT, [O.T.S.], [METRONOME], TRANSPOSE, TUNE, BEAT, TOUCH, SPLIT, DSP LEVEL, USB.
- Connections: USB port, headphones, audio output, pedals (sustain, soft, sostenuto).



## 4 Setup guide

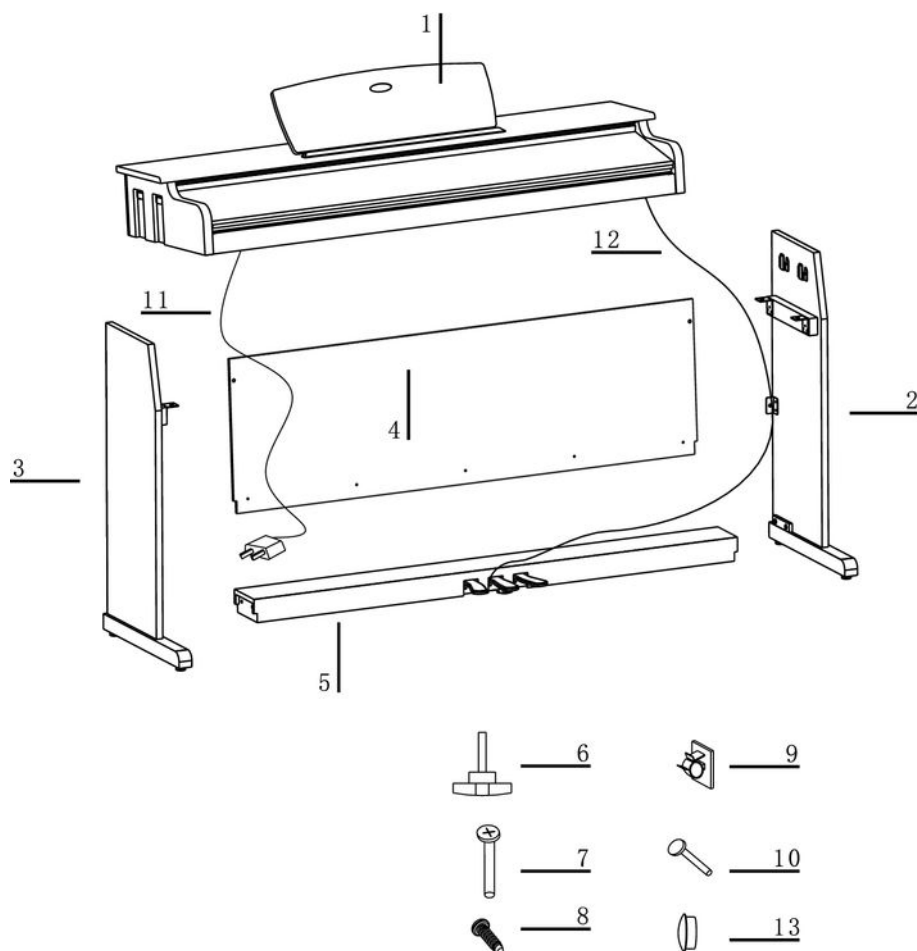

You need a Phillips screwdriver (not supplied) to assemble the stand. Open the packaging and please make sure prior to assembly that you have the full scope of delivery available as listed below.

1. Digital piano housing with music stand	8. Screws 4 × 15 (5 pcs.)
2. Right side panel	9. Cable holder
3. Left side panel	10. Screw 6 × 12 (2 pcs.)
4. Rear wall	11. Mains cable
5. Pedal box	12. Pedal cable
6. Handscrew (4 pcs.)	13. Plastic cap (4 pcs.)
7. Screws 6 × 30 (4 pcs.)	

## Mechanical setup

1. ➤ Assemble the piano near a wall power outlet.
2. ➤ Proceed according to the illustrations and exclusively use the supplied screws. Using other screws could damage the housing of the digital piano or result in a reduced stability of the digital piano.
  - (6) Handscrews (4 pcs.),
  - (7) Screws 6 × 30 (4 pcs.)
  - (8) Screws 4 × 15 (5 pcs.) and
  - (10) Screws 6 × 12 (2 pcs.) for rear wall mounting.

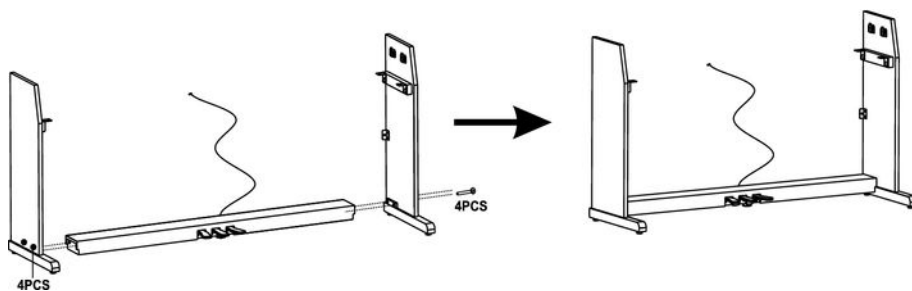

3. ➤ Set the pedal box (5) between the left and right side panel ((2) and (3)) and use 2 screws M 6 × 30 (7) on each side to affix both side panels to the pedal box. Insert the four plastic caps (13) into the screw holes.

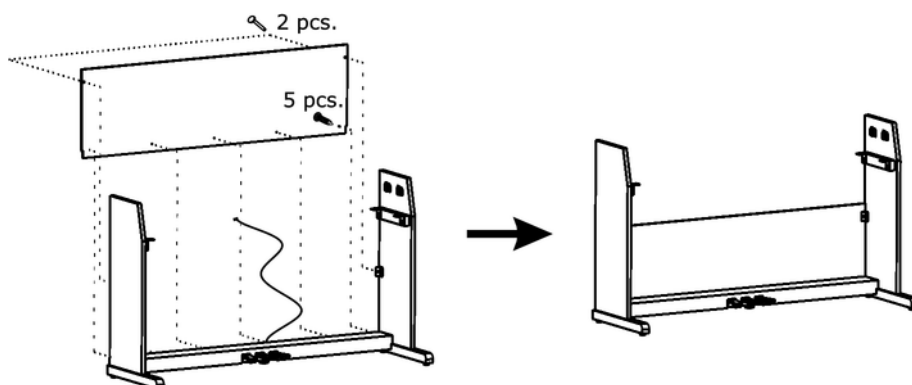

4. ➤ Attach the rear wall with 5 screws 4 × 15 (8) to the pedal box (5) and with two screws 6 × 12 (11) to the rear sides of the side panels ((2) and (3)).

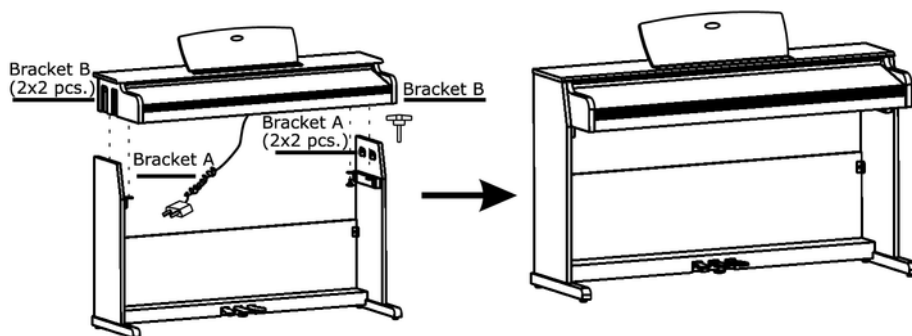

5. ➤ Put the housing of the digital piano on the stand and affix it using the four hand screws (6).

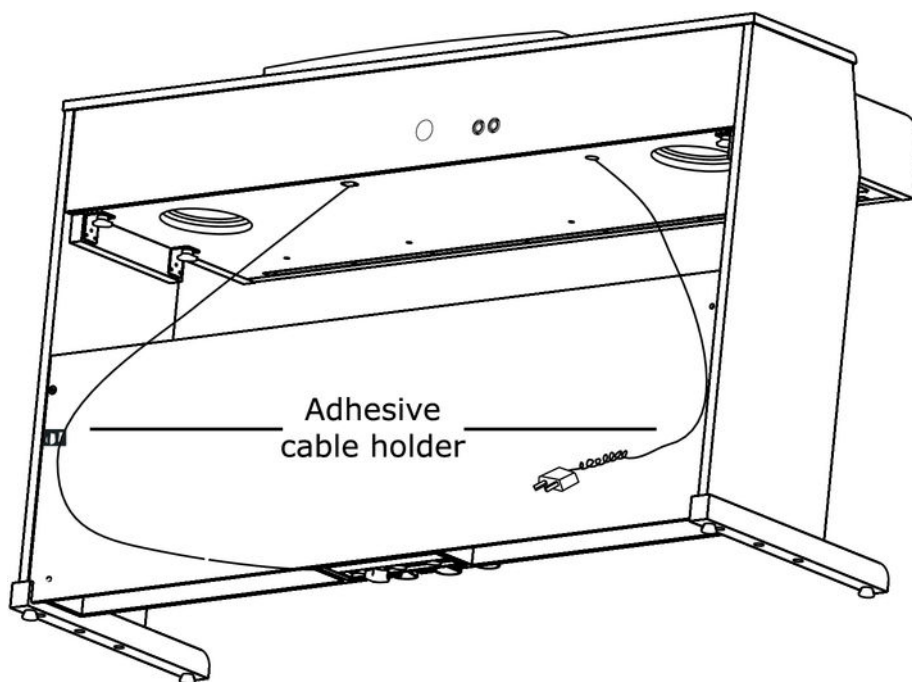

6. ➔ Attach the two adhesive cable holder as shown here on the base. Connect the DIN plug of the pedal cable to the PEDAL jack on the underside of digital piano. Attach the cable to the cable holder. Move the digital piano to its designated location.

#### Mains connection



1. ➔ Make sure the unit is switched off before connecting it to the power supply or disconnecting it.

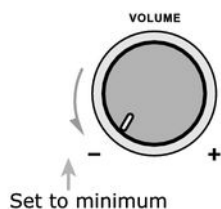

2. ➔ Turn the volume control down to the left stop.

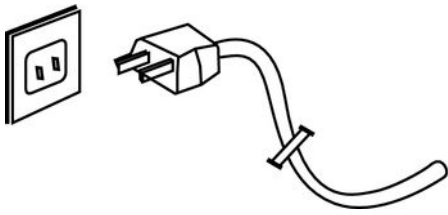

**3.** ➤ Connect the AC power cord to a properly wired AC 230 V mains wall outlet.



**4.** ➤ Now you're ready to turn the device on.



*If the piano is not in use or when a thunder-storm threatens, disconnect the unit from the mains to ensure safety.*

Views

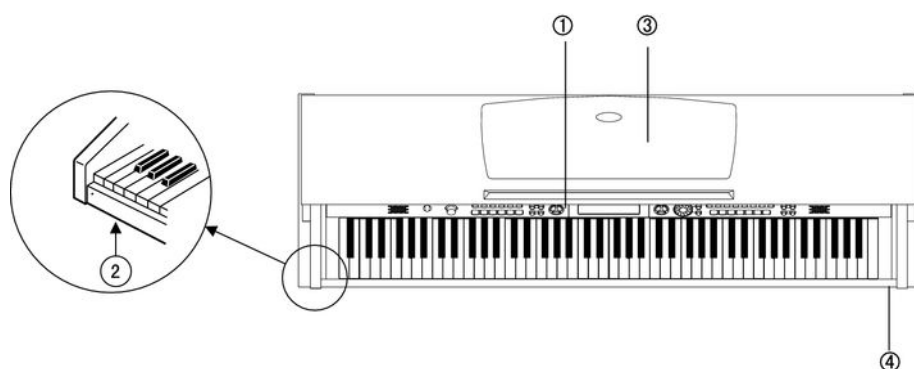

From above

1. Control panel	3. Music stand
2. Headphones socket	4. Piano keyboard

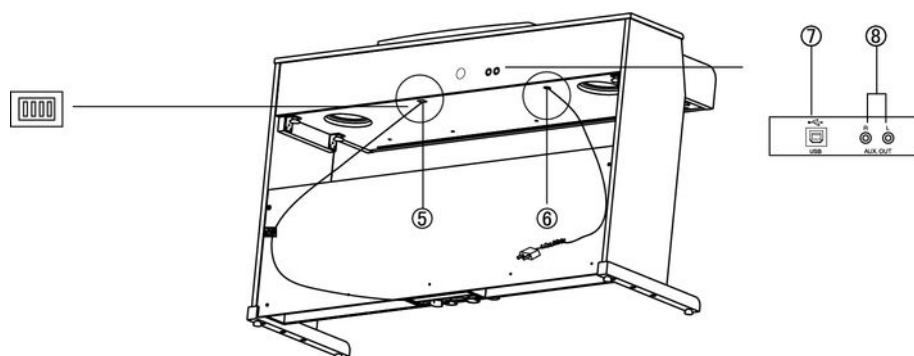

Rear side

5. Connection for the pedal cable	7. USB port
6. Mains cable	8. AUX stereo output

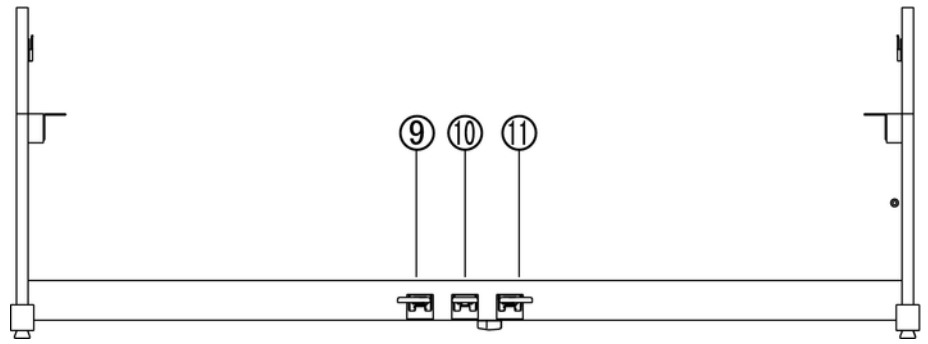

**Pedals**

9. Soft pedal	11. Sustain pedal
10. Sostenuto pedal	

## 5 Operating panel and connections

### Operating panel

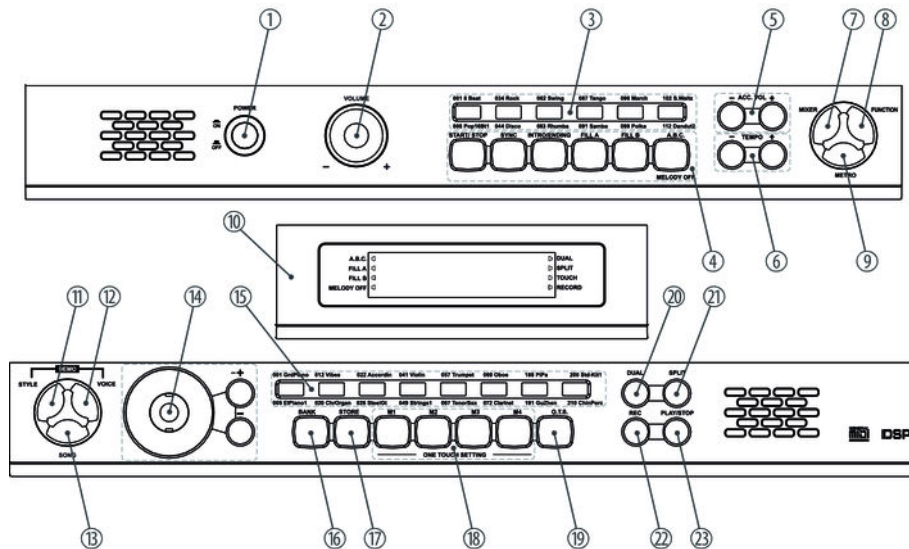

1	On / off switch	
2	Volume control	
3	Direct selection buttons [STYLES]	
4	Buttons to operate the STYLES mode	Buttons to operate the SONG mode
	<ul style="list-style-type: none"> <li>■ START/STOP</li> <li>■ SYNC</li> <li>■ INTRO/ENDING</li> <li>■ FILL A</li> <li>■ FILL B</li> <li>■ A.B.C.</li> </ul>	<ul style="list-style-type: none"> <li>■ MELODY OFF</li> </ul>
5	[ACC. VOL +]/[ACC. VOL -] buttons for accompaniment volume control.	
6	[TEMPO +]/[TEMPO -] buttons to increase / decrease the tempo.	
7	[MIXER] button to adjust the volume of the various tracks.	
8	[FUNCTION] button to call the function menu.	
9	[METRO] button: metronome.	
10	Display.	
11	[STYLE] button.	
12	[VOICE] buttons to select the instrument voice. Press the buttons ([STYLE] + [VOICE]) simultaneously to activate the DEMO mode.	

13	[ <i>SONG</i> ] button to select the practise songs.
14	Selection field with jog dial and [+ ] and [ - ] buttons.
15	Direct selection buttons [ <i>VOICE</i> ] to select the instrument voice.
16	[ <i>BANK</i> ] buttons to select the memory bank.
17	[ <i>STORE</i> ] button.
18	Memory slot buttons [ <i>M1</i> ] to [ <i>M4</i> ] in 'One Touch Setting' area.
19	[ <i>O.T.S</i> ] button - One Touch Setting.
20	[ <i>DUAL</i> ] button to call the dual mode (two voices simultaneously).
21	[ <i>SPLIT</i> ] button to call the split mode (two different voices in different keyboard areas).
22	[ <i>REC</i> ] button to call the recording mode.
23	[ <i>PLAY/STOP</i> ] button for playback and pausing the recording.

## Display

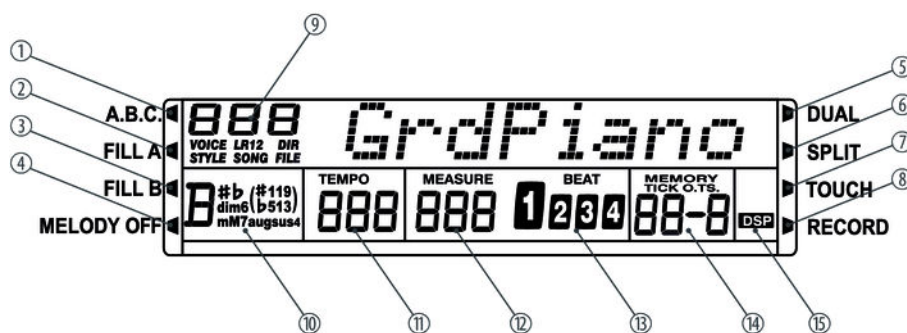

1	A.B.C. (automatic chord detection and bass accompaniment)	9	VOICE / STYLE / SONG / DIR (directory) /FILE
2	FILL A (fill bar A)	10	CHORD
3	FILL B (fill bar B)	11	TEMPO
4	MELODY OFF (to mute the right hand)	12	MEASURE
5	DUAL (dual mode)	13	BEAT
6	SPLIT (split mode)	14	MEMORY / TICK (metronome) / O.T.S.
7	TOUCH (touch sensitivity)	15	DSP
8	RECORD		



## 6 Connection options

### Headphones

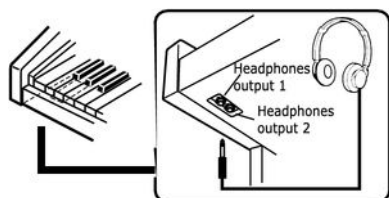

To the left beneath the keyboard you find the headphones outlets.

1. ➤ Connecting headphones (not supplied) to outlet 2 mutes the speakers.
2. ➤ Using outlet 1 maintains the sound output through the speakers.



- *Never operate headphones at high volume as this can permanently damage your hearing.*
- *Before connecting the mains voltage or other devices to the piano, turn the volume to 'minimum' to avoid damage to the speakers.*

### AUX output

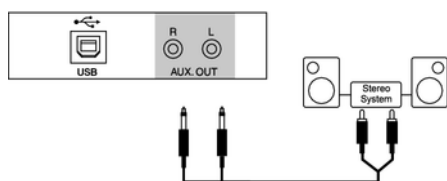

You can connect powered speakers, your stereo device or other amplifiers to the rear AUX outlet.



*Connect both channels (L and R) for stereo sound. Connect only one of the two channels of mono sound.*

### USB port

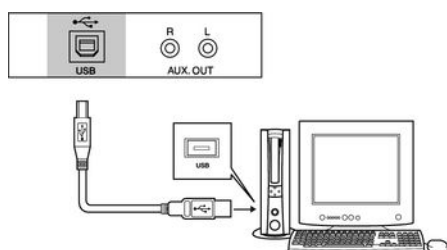

1. ➤ Connect a computer or other device with USB support.
2. ➤ The USB port is an integrated MIDI-USB adapter. For devices with USB cable, you can simply connect the MIDI / USB converter to the USB port and connect the MIDI IN or MIDI OUT cable to the digital piano. After the driver has been installed and the installation is complete, you can select the USB audio device in Device menu of the software to transfer the MIDI data.

## 7 Switching on / off and basic operation

### 7.1 Switching the digital piano on

#### 7.1.1 Switching on, volume control

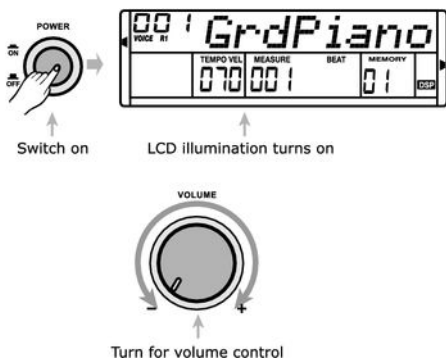

1. ➤ Please check that the device is connected properly.
2. ➤ Press the [POWER] button to switch the device on. The display is illuminated.
3. ➤ Turn the volume control [VOLUME] to set the desired volume.



- If the display does not light up after switching the piano on, check the power supply.
- If you hear nothing from the speakers, the volume may be set to 'minimum'.

### 7.2 Song selecting

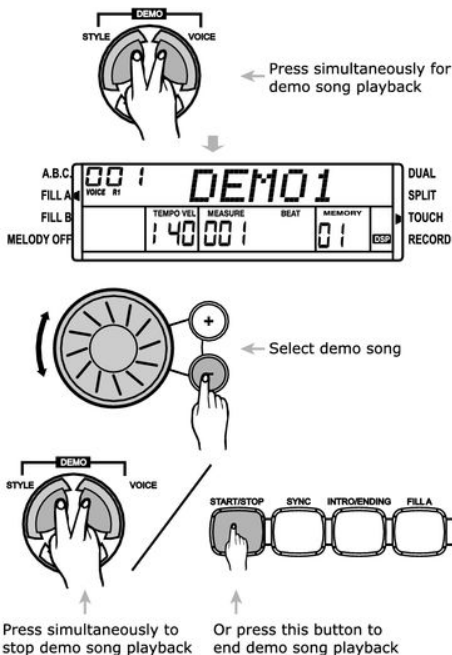

The piano offers 3 demo songs in total (see appendix).

1. ➤ Press the buttons [VOICE] and [STYLE] simultaneously to play demo songs.
2. ➤ Press the [+] or [-] button or turn the jog dial to select the number of the desired demo song.
3. ➤ Press the buttons [VOICE] and [STYLE] simultaneously again or press the [START/STOP] button to stop the playback.

## 8 Functions

### 8.1 Voices and effects

#### 8.1.1 Selecting voices

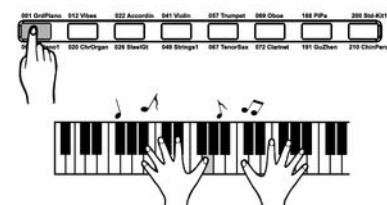
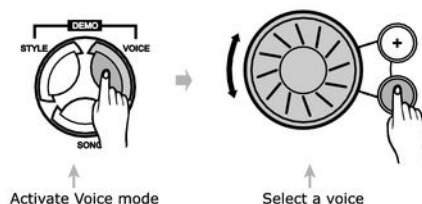

The digital piano offers 210 voices in total.

1. ➤ 16 voices can be called via the direct selection button. Each direct selection button hosts 2 voices. Press once to activate the voice labelled above the button. Press twice to activate the voice labelled below the button.

On switching on, 'VOICE R1' lights up in the display and the name of voice 001 is displayed.

2. ➤ To select other voices press the direct selection keys, the [+]/[-] buttons or turn the jog dial.



If you activate the VOICE mode for the first time by pressing the [VOICE] button the display shows 'VOICE R1' (right hand voice). Press the [VOICE] button repeatedly to sequentially activate the following additional modes => 'VOICE R2' (second right hand voice in Dual Mode) => 'VOICE L' (left hand voice) => 'VOICE R1' (right hand voice).

#### 8.1.2 Dual mode

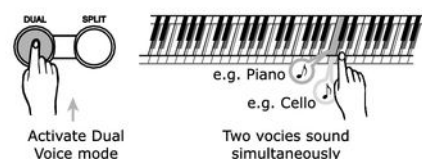

In Dual mode, you can play two voices simultaneously. When Dual mode is off, 'VOICE R1' is displayed. When Dual mode is on, 'VOICE R2' is displayed.

1. ➤ Press the buttons [+]/[-] or turn the jog dial to select the desired voice. The default preset voice in Dual mode is No. '050 Strings2'.
2. ➤ Press the [DUAL] button again to quit the Dual mode. 'VOICE R2' is disabled and you only hear the 'VOICE R1' voice.



When the keyboard is split, the Dual mode affects only keys to the right of the keyboard split point. The area to the left of the split point is then meant for chord playing.

### 8.1.3 Split mode

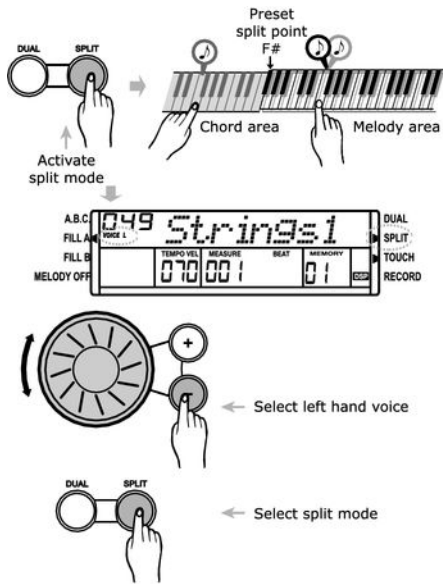

With this function, you can assign different voices to separate keyboard areas.

1. ➤ Press the button *[SPLIT]* to activate the Split mode and thus the left hand voice. The indicators 'VOICE L' and 'SPLIT' then appear simultaneously in the display.
2. ➤ Press the buttons *[+]* or *[-]* or turn the jog dial to select the desired voice. The default preset left hand voice in Split mode is No. '049 Strings1'.
3. ➤ Press the *[SPLIT]* button again to quit the Split mode. The 'SPLIT' display turns off.

## 8.2 Style operation

The digital piano offers 120 styles (001 to 120). Style '001' is preset by default.

### 8.2.1 Selecting a style

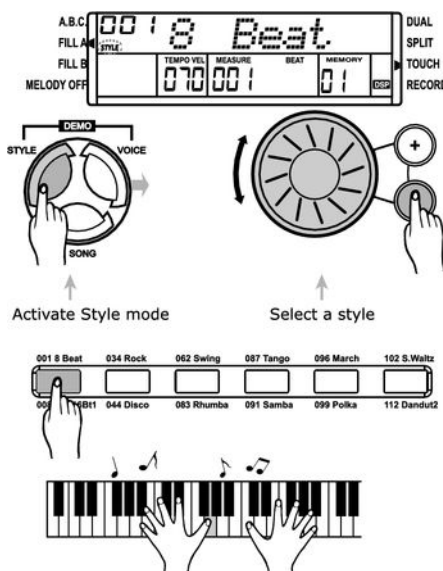

1. ➤ Press the button *[STYLE]* to select the Style mode. The display shows 'STYLE' and the selected number and description.
2. ➤ Press the *[+]* / *[-]* buttons or use the jog dial to select the desired style.
3. ➤ Direct selection buttons:

You can also select the desired style using the direct select buttons. Two styles are assigned to each direct select button, specified above and below each button.



- Press the same button twice to toggle between upper and lower style.
- If you press another direct select button, the style is activated depending on whether an upper or lower style was selected before.

## 8.2.2 Accompaniment function

The accompaniment function is controlled via five parameters: INTRO, NORMAL, VARIATION, FILL (A-A, A-B, B-A, B-B) and ENDING.

### 1. ▶ **INTRO**

To add an intro, press the *[INTRO/ENDING]* button before starting to play. Depending on the selected style, the rhythm starts with two to four bars, followed by the main section.

### 2. ▶ **NORMAL** and **VARIATION**

There are two main sections: normal and variation. Depending on the style, each section consists of two to four bars.

### 3. ▶ **FILL**

With activated accompaniment, you can press the button *[FILL A]* or *[FILL B]* to insert a rhythm and accompaniment part.

### 4. ▶ **ENDING**

If you press the button *[INTRO/ENDING]* while accompaniment is activated, an ending section appropriate for the accompaniment is inserted that ends the performance.

### 8.2.3 Starting a style

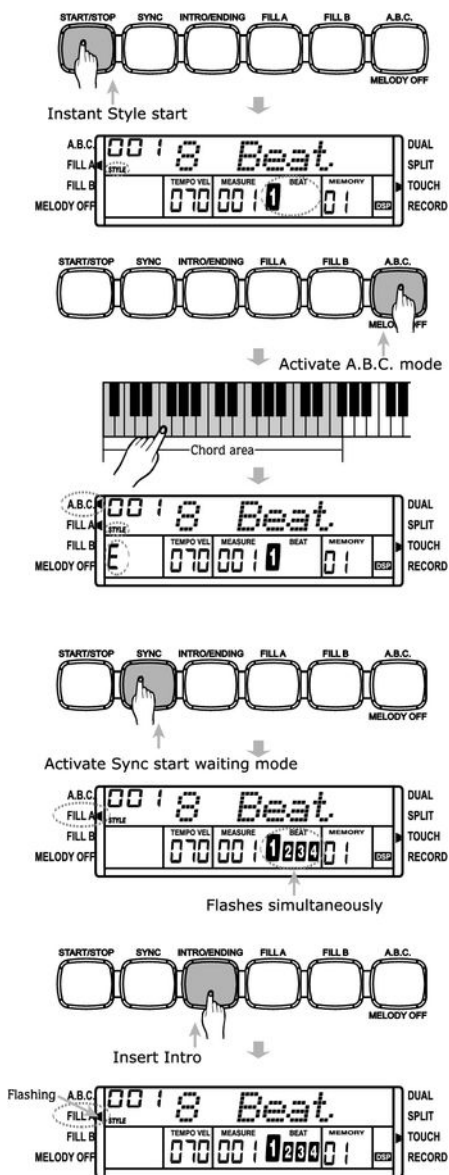

**1.** Instant start

Press the [START/STOP] button to start the style.

**2.** Chord mode (A.B.C.)

Press the [A.B.C./MELODY OFF] button once to activate the Chord mode. The A.B.C. symbol appears in the display. The area to the left of the split point is now considered to be the chord area. When you play a chord with one or more fingers, both the bass and the chord will sound simultaneously.

There are two ways to detect the chord: single finger and multi finger detection. If the chord is played according to the chord dictionary (see Chapter 8.2.8 'Chord detection' on page 24) the chord is considered as recognized and is output accordingly. If not, the single finger chord will be recognized.

**3.** SYNC START

Press the [SYNC] button.

⇒ 'BEAT 1' to 'BEAT 4' are flashing in the display according to the current tempo. If you play the piano in this mode the style is automatically started.

**i** – If the Chord mode is deactivated press any key on the keyboard. Then, only the percussion rhythm is played.

– If the Chord mode is activated press any key of the chord area to start the style with automatic bass and chord accompaniment.

**4.** INTRO/ENDING

Press the [INTRO/ENDING] button to insert an intro before this style is playing.

Press the [START/STOP] button to start the intro, followed by the main section.

If you press the [INTRO/ENDING] button in style playing the style ends after playing.

## 8.2.4 Fill A/B

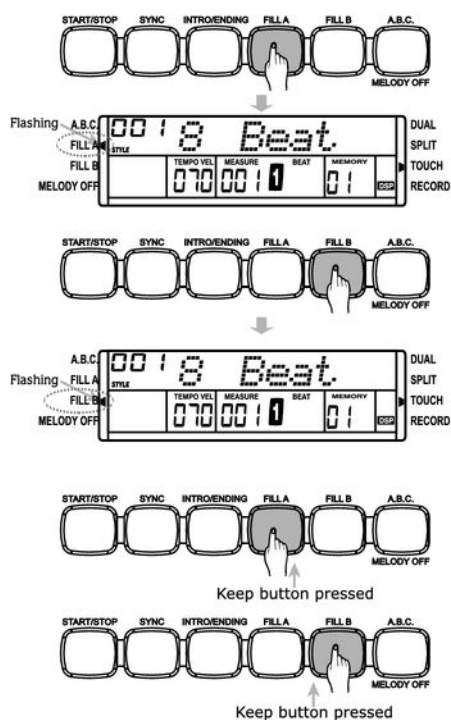

Use this function to add fill bars.

1. In NORMAL mode, press the [FILL A] button to insert one fill bar. 'FILL A' is flashing in the display. When the bar has ended the piano returns to NORMAL mode.
2. In NORMAL mode, press the [FILL B] button to insert one fill bar. 'FILL B' is flashing in the display. When the bar has ended the piano changes to the VARIATION mode.
3. In VARIATION mode, press the [FILL A] button to insert one fill bar. 'FILL A' is flashing in the display. When the bar has ended the piano changes to the NORMAL mode.
4. In VARIATION mode, press the [FILL B] button to insert one fill bar. 'FILL B' is flashing in the display. When the bar has ended the piano returns to VARIATION mode.



- If you keep the button [FILL A] or [FILL B] pressed while a style is playing, the selected fill pattern is played until you release the button.
- Press the [FILL A] button after style playing has ended. Then the change to the NORMAL section takes place and 'FILL A' lights up in the display.
- Press the [FILL B] button after style playing has ended. Then the change to the VARIATION section takes place and 'FILL B' lights up in the display.

## 8.2.5 Ending a style

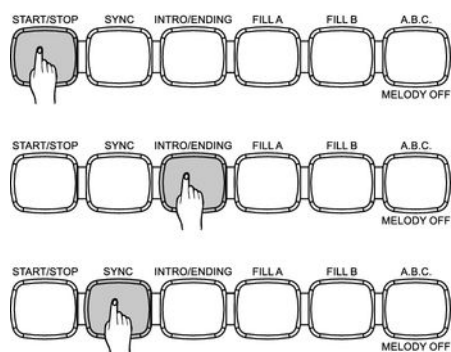

1. Instant ending  
You can exit the accompaniment function any time by pressing the [START/STOP] button.
2. Ending  
Press the [INTRO/ENDING] button to finish the performance with an ending. The style stops after the ending.
3. SYNC  
Press the [SYNC] button to stop the style. The synchronised start mode is activated.

### 8.2.6 Accompaniment volume

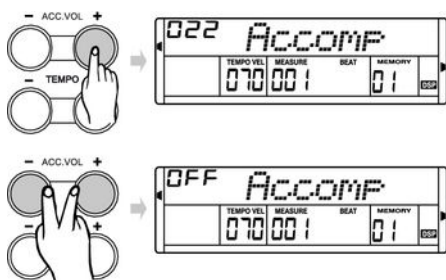

1. ➤ You can adjust the volume of the styles via the volume of the accompaniment.
2. ➤ Press the button [ACC. VOL +] or [ACC. VOL -] to set the volume.
3. ➤ When pressing the [ACC. VOL +] and [ACC. VOL -] buttons simultaneously, the accompaniment track is muted.

### 8.2.7 Tempo

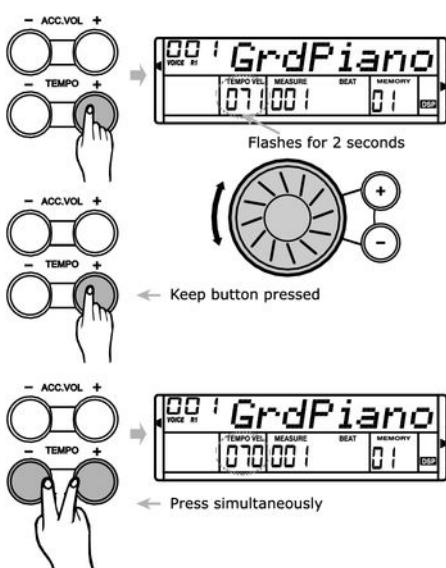

1. ➤ Press the buttons [TEMPO +] or [TEMPO -]. The set value flashes for about 2 seconds in the display.
2. ➤ Within this time you can adjust the tempo in a range of 30 to 280 using the jog dial.
3. ➤ Keep the [TEMPO +] or [TEMPO -] button pressed to change the value quickly.
4. ➤ Press the buttons [TEMPO +] and [TEMPO -] simultaneously to reset the tempo to the preset default value.



- When Style is not active, the tempo will be set automatically to the default value along with the style.
- When Style is active, the tempo will not change with the style you select.

### 8.2.8 Chord detection

The 'Auto Bass Chord' function (A.B.C.) is turned off by default. Press the [A.B.C./MELODY OFF] button to turn 'A.B.C.' on. The keyboard area to the left of the split point is already known as the chord area. When you now play a chord, bass and chord voices will sound together.



As the A.B.C. chord detection is based on the root note of the chord, some chords that could be played according to the chord dictionary can not be recognised by A.B.C., such as B6, B<sub>b</sub>6, B<sub>b</sub>6(9), B6(9), Baug, B<sub>b</sub>aug, B<sub>b</sub>m6, Bm6, Adim7, B<sub>b</sub>dim7, Bdim.







**Two ways to detect the chord: 'single finger detect' and 'multi-finger detect'**

If the chord is played on base of the illustration for multi-finger chords below, it will be detected as a 'multi-fingered' chord. If not, it will be detected as a 'single-finger' chord.

■ 'Single-finger' chords

Using this method, you can play chords with just one, two or three fingers within the possibilities of the accompaniment function. In the following, we list some examples for single-finger chords (C, Cm, C7 und Cm7).

































<p><b>C</b></p> 	<p>• <b>To play a major chord</b> Press the root note of the chord</p>
<p><b>Cm</b></p> 	<p>• <b>To play a minor chord</b> Press the root note together with the nearest black key to the left of it .</p>
<p><b>C7</b></p> 	<p>• <b>To play a seventh chord</b> Press the root note together with the nearest white key to the left of it .</p>
<p><b>Cm7</b></p> 	<p>• <b>To play a minor seventh chord</b> Press the root notes together with the nearest white and black keys to the left of it (three keys altogether) .</p>



*Press the keys to the left of the split point with the A.B.C. function activated. The chords are recognized as single-finger chords.*

■ 'Multi-fingered' chords

Using this method, you can play chords with normal fingering within the possibilities of the accompaniment function. In the following we list 32 chords using C-chords as example.

0 C 	1 C <sub>6</sub> 	2 C <sub>M7</sub> 	3 C <sub>M7</sub> (#11) 	4 C <sub>M</sub> (9) 	5 C <sub>M7</sub> (9) 
6 C <sub>6</sub> (9) 	7 C <sub>aug</sub> 	8 C <sub>m</sub> 	9 C <sub>m6</sub> 	10 C <sub>m7</sub> 	11 C <sub>m7</sub> (b5) 
12 C <sub>m</sub> (9) 	13 C <sub>m7</sub> (9) 	14 C <sub>m7</sub> (11) 	15 C <sub>m</sub> M <sub>7</sub> 	16 C <sub>m</sub> M <sub>7</sub> (9) 	17 C <sub>dim</sub> 
18 C <sub>dim7</sub> 	19 C <sub>7</sub> 	20 C <sub>7sus4</sub> 	21 C <sub>7</sub> (b5) 	22 C <sub>7</sub> (9) 	23 C <sub>7</sub> (#11) 
24 C <sub>7</sub> (b13) 	25 C <sub>7</sub> (b9) 	26 C <sub>7</sub> (13) 	27 C <sub>7</sub> (#9) 	28 C <sub>M7aug</sub> 	29 C <sub>7aug</sub> 
30 C <sub>sus4</sub> 	31 C <sub>1+2+5</sub> 	The notes in brackets are optional; the chords will also be recognised without them.			

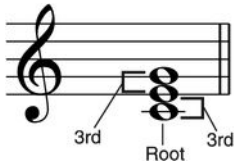

Major third – four half steps (semitones)

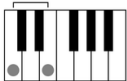

Minor third – three half steps (semitones)

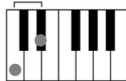

■ Chord basics

A chord consists of three or more notes played together. The most common chord is the triad consisting of three notes: root, third and fifth of the corresponding scale. The C-major chord, for example, is formed from the notes C (root), E (the third note of the C major scale) and G (the fifth note of the C major scale). In the shown chord C major, the lowest note is the root note (this is the basic form of the chord - if you play other notes of the chord as the lowest note, this is called 'chord inversion'). The root note is the central tone of the chord on which the other chord notes are based. The distance (interval) between adjacent notes and the root note determines whether the result will be a third major or minor.

■ Chordal structure

The lower interval in our triad (between the root and third) determines whether the result will be a major or minor triad. In addition, we can get the highest note by a half step up or down to create two additional chords.

The basic characteristic of the triad is obtained, even if we change the order of notes to create different inversions. Successive chords can be linked together in a soft chord progression, e.g. by selecting appropriate chord inversions (also called 'voicings').

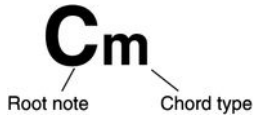

<p><b>Major chord</b></p> <p><b>C<sup>M</sup></b></p> <p>Minor 3rd    Major 3rd</p>	<p><b>Minor chord</b></p> <p><b>C<sup>m</sup></b></p> <p>Major 3rd    Minor 3rd</p>	<p><b>Augmented chord</b></p> <p><b>C<sup>aug</sup></b></p> <p>Major 3rd    Major 3rd</p>	<p><b>Diminished chord</b></p> <p><b>C<sup>dim</sup></b></p> <p>Minor 3rd    Minor 3rd</p>
---	---	---	--

■ Chord names

Chord names tell you just about everything you need to know about a chord. The chord name tells you the root note, whether it is major, minor or diminished chord, whether it requires a major or flatted seventh and what alterations or tension are used – everything at a glance.

■ Some chord types

<p><b>Suspended 4<sup>th</sup></b></p> <p><b>C<sup>aus4</sup></b></p> <p>Perfect 5<sup>th</sup>    Perfect 4<sup>th</sup></p>	<p><b>7<sup>th</sup></b></p> <p><b>C<sup>7</sup></b></p> <p>Flatted 7<sup>th</sup>    Major chord</p>	<p><b>Minor 7<sup>th</sup></b></p> <p><b>C<sup>m7</sup></b></p> <p>Flatted 7<sup>th</sup>    Minor chord</p>	<p><b>Major 7<sup>th</sup></b></p> <p><b>C<sup>M7</sup></b></p> <p>Major 7<sup>th</sup>    Major chord</p>
<p><b>Minor/major 7<sup>th</sup></b></p> <p><b>C<sup>mM7</sup></b></p> <p>Major 7<sup>th</sup>    Minor chord</p>	<p><b>7<sup>th</sup>, flatted 5<sup>th</sup></b></p> <p><b>C<sup>7(s)</sup></b></p> <p>Flatted 5<sup>th</sup>    7<sup>th</sup> chord</p>	<p><b>Minor 7<sup>th</sup>, flatted 5<sup>th</sup></b></p> <p><b>C<sup>m7(s)</sup></b></p> <p>Flatted 5<sup>th</sup>    Minor 7<sup>th</sup> chord</p>	<p><b>7<sup>th</sup>, suspended 4<sup>th</sup></b></p> <p><b>C<sup>7sus4</sup></b></p> <p>Flatted 7<sup>th</sup>    Suspended 4<sup>th</sup> chord</p>

8.2.9 Metronome

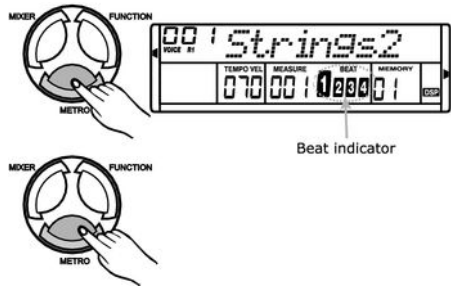

1. ➤ Press the [METRO] button to activate the metronome. You can select the beat in the Function menu.
2. ➤ Press the [METRO] button again to turn the metronome off.
3. ➤ If the style mode is deactivated the beat follows the selection in the functions menu after turning on the metronome. If style mode is activated the beat setting follows the current style.
4. ➤ The metronome can be activated together with the style. If the style plays at first, the metronome will be enabled with the next bar. On the other hand, the metronome responds at once to the first beat of the style.

8.3 Function menu

Press the [FUNCTION] button to call the function menu. The first function shown after starting the menu is always 'Transpos'. Press the button [FUNCTION] repeatedly to select the desired option. Then change the parameter using the jog dial or the buttons [+ ] or [-]:

Option	Display	Value range	Default value
Transpose	Transpos	-12 to +12	0
Fine tuning	Tune	-50 to 50	0
Beat	Beat	0, 2 to 9	4
Touch sensitivity	Touch	OFF, 1, 2, 3	2
Split point	Split pt	1 to 88	34 (F3#)
Reverb level	DSPlevel	OFF, 1 to 7	2
MIDI receive channel	Midi In	01 to 16, ALL	ALL
MIDI send channel	Midi Out	01 to 16	01



If you don't press a key within five seconds after you enter the function menu, the menu will close automatically.

## 8.3.1 Transposing

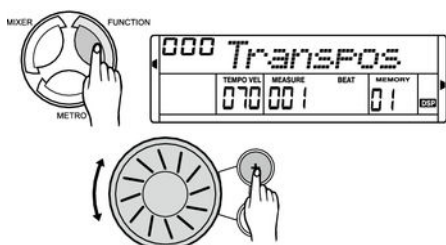

This function lets you adjust the keyboard pitch in 12 semitone steps up or down.

1. First, press the [FUNCTION] button to open the TRANSPOSE menu. The display shows the current setting.
2. Press the [+] / [-] buttons or turn the jog dial to shift the pitch up or down. The default value is '000'.
3. Press the buttons [+] and [-] simultaneously to restore the preset '000' (no transposing).



If you don't press a button for five seconds after opening the TRANSPOSE menu, it will be automatically cancelled.

### 8.3.2 Fine tuning

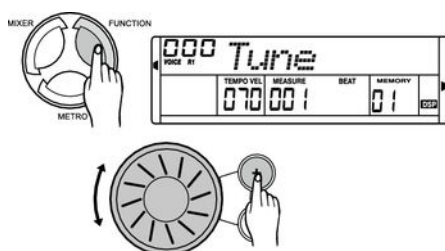

Use this function to fine tune the entire keyboard in cent increments.

- ➔ The display shows the current setting. Use the jog dial or the buttons [ + ] or [ - ] to change the tuning within a range of -50 to +50 cents. Each keystroke changes the value by 1 cent. Press the buttons [ + ] and [ - ] simultaneously to reset the tuning to the preset value.

### 8.3.3 Beat



This function sets the beat value in a range of 0 to 9.

- ➔ The display shows the current setting. Use the jog wheel or the buttons [ + ] or [ - ] to change the beat.

### 8.3.4 Touch sensitivity

This function lets you adjust the touch response of the keyboard in four steps.

Parameter	Description
'OFF'	Touch sensitivity is off, very recommendable when playing the organ voice.
'001'	Soft In this setting, the volume is higher than usual even when playing with a soft touch.
'002'	Normal This setting corresponds to the usual touch response of a keyboard.
'003'	Hard In this setting, the volume is lower than usual even when playing with a hard touch.



- ➔ The display shows the current setting. Use the jog wheel or the buttons [ + ] or [ - ] to change the touch sensitivity.
- ➔ When selecting 'OFF', the 'TOUCH' indicator turns off and the function is deactivated.

## 8.3.5 Split point



This function lets you set the point that separates the entire keyboard into two sections.

1. ➔ The display shows the current setting.
2. ➔ Use the jog dial or the [+]/[-] buttons to change the split point. You can also just press the key you would like to set as split point. The keys to the right of the split point are considered to be the right hand area, the opposite side is the left hand area (chord area).



*Parameter range: 1 to 88. Default setting: 34 (F3#).*

## 8.3.6 DSP effect level



- ➔ In the 'DSP Level' function menu, set the desired value using the jog dial or the [+]/[-] buttons.



*Parameter range: OFF, 1 to 7. Default setting: '2'.*

## 8.3.7 MIDI receive channel (Midi In)



- ➔ In the 'Midi In' function menu, you can set the channel on which the digital piano receives MIDI data from other devices. Use the jog dial or the [+]/[-] buttons to select the MIDI receive channel(s).



*Parameter range: channels 1 to 16 or 'ALL' for all channels. Default setting: 'ALL'.*

### 8.3.8 MIDI send channel (Midi Out)



➔ In the 'Midi Out' function menu, you can set the channel on which the digital piano sends MIDI data to other devices. Use the jog dial or the [+]/[-] buttons to select the MIDI send channel.



Parameter range: channels 1 to 16. Default setting: '001'.

### 8.4 Mixer menu



Use this menu to set the volume for the various style elements and instrument voices.

1. ➔ Press the [MIXER] button to call the mixer menu. By default, the first option after opening this menu is 'Drum Vol'.
2. ➔ Press the [MIXER] button repeatedly to select the desired option. Subsequently, you can set the selected parameter using the jog dial or the [+]/[-] buttons.

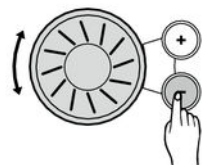

If you don't press a key within five seconds after you've entered the mixer menu, it will close automatically.

#### Adjustable options and parameter

Option	Display	Value range	Standard	Description
DRUM volume	Drum Vol	000 to 031	020	Percussion accompaniment
Bass volume	Bass Vol	000 to 031	018	Bass accompaniment
ORCHESTRA	Oc Vol	000 to 031	021	Orchestra accompaniment
UPPER1 volume	Voice R1	000 to 031	024	Right hand voice
UPPER2 volume	Voice R2	000 to 031	012	Second right hand voice in dual mode
LOWER volume	Voice L	000 to 031	012	Left hand voice

## 8.5 Memory

You can store up to 16 complete control panel setups that you can recall whenever needed.

### 8.5.1 Memory banks

There are four memory banks in total. Each bank contains four memory slots (M1 to M4).

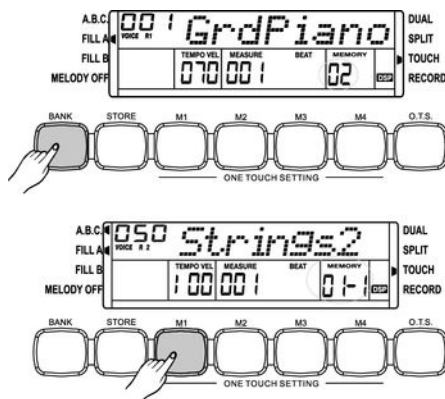

1. ➤ Press the [BANK] button repeatedly to select the desired memory bank. The display shows 'MEMORY 0X'.
2. ➤ Press one of the buttons [M1] to [M4] to select one of the four memory slots. The display shows 'MEMORY 0X-X'.

### 8.5.2 Memory data

You can store the settings for the following functions as data in the memory:

- Right hand voice R1
- Second right hand voice R2
- Left hand voice L
- Style
- Tempo
- Function
- Mixer
- Accompaniment volume.



*If the current memory data are changed, the corresponding memory indicator in the display turns off.*



### 8.5.3 Storing & loading parameters

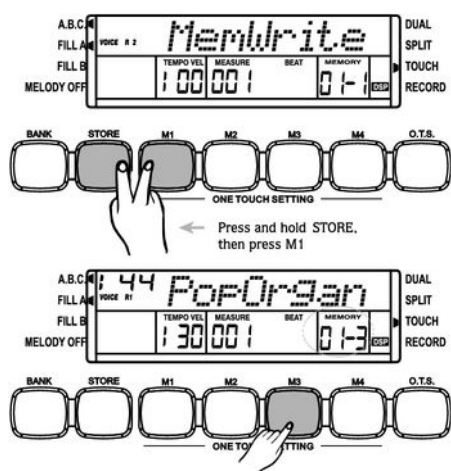

1. ➔ Keep the [STORE] button pressed and press one of the buttons [M1] to [M4] simultaneously. Then the data will be stored in the respective memory slot (M1 to M4). Please note that any previously stored data will be overwritten.
2. ➔ Press one of the buttons [M1] to [M4]. The data is then loaded from the corresponding memory slot replacing the current settings. The respective memory slot number appears in the display.



When you turn off the digital piano, the stored data is retained.

### 8.5.4 Deleting memory data

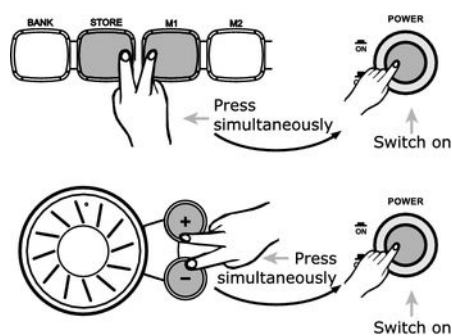

1. ➔ If you keep the buttons [STORE] and [M1] pressed while powering the digital piano up, the current memory data will be saved as the default values.
2. ➔ If you keep the buttons [+] and [-] pressed while powering the digital piano up, the factory default values are loaded and stored songs are deleted.

### 8.6 One Touch Setting

One Touch Setting (O.T.S.) is a convenient feature that allows you to immediately reconfigure all the settings with just one single keystroke. These are rhythm-based combinations of instrument voices. With this function, four types of parameters can be loaded (M1 to M4).

The standard parameter saved in the O.T.S. are:

- Right hand voice R1
- Second right hand voice in dual mode R2
- Left hand voice L
- R1 volume
- R2 volume

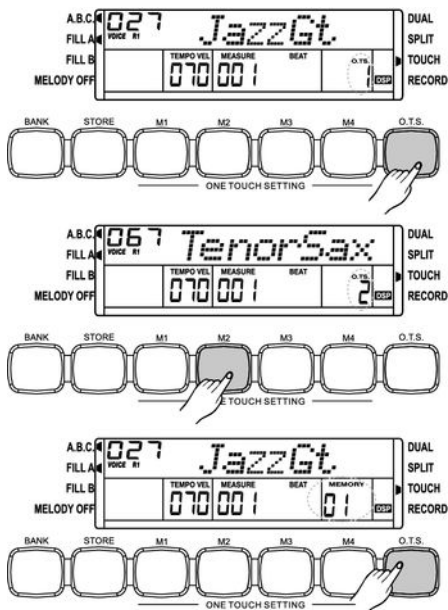

- Orchestra accompaniment for R1
- Orchestra accompaniment for R2.

1. ➤ Select a style.
2. ➤ Press the [O.T.S.] button to start this mode. 'O.T.S.' appears in the display. Press one of the buttons [M1] to [M4]. Then the device loads the respective parameter types that suit to the current style. Thereby, the A.B.C. mode is turned on automatically.
3. ➤ Press one of the buttons [M1] to [M4] that provide the desired settings.
4. ➤ Press the [O.T.S.] button again to quit the O.T.S. mode. The display shows 'MEMORY'.



*If you press one of the [M1] to [M4] buttons while recording a song or playing a recorded song, no 'FILL IN' will be inserted.*

## 8.7 Recording and playback

### 8.7.1 Recording standby

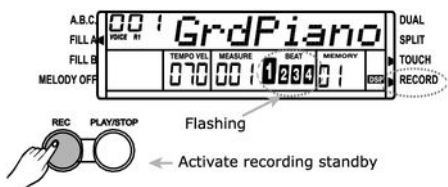

1. ➤ Press the [RECORD] button to activate the Recording mode. 'RECORD' lights up in the display. 'BEAT 1' to 'BEAT 4' start flashing synchronously and thus indicate Recording standby.
2. ➤ Now you can select the instrument voices and the style number, and set the tempo and mixer parameters.

### 8.7.2 Start recording

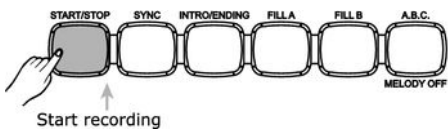

1. ➤ When 'BEAT 1' to 'BEAT 4' are flashing in the display, press the [START/STOP] button or one of the piano keys to start recording.

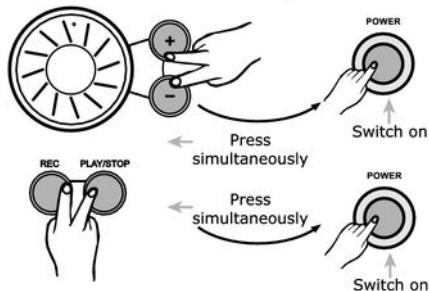

2. ➔ 'BEAT 1' to 'BEAT 4' light up according to the current tempo.



- When you turn off the digital piano, the stored data is retained.
- If you keep the buttons [+ ] and [- ] pressed while powering the digital piano up, the factory default values are loaded and stored songs are deleted.
- If you keep the buttons [RECORD] and [PLAY/STOP] pressed while powering the digital piano up, the recorded data is deleted.

### 8.7.3 Stop recording



➔ Press the [RECORD] button a third time to stop the recording. If you're recording an accompaniment track press the [INTRO/ENDING] button to finish the recording after the ending section. The recording stops automatically when the memory is full. In this case, 'Full' appears in the display.

### 8.7.4 Recording playback



1. ➔ Press the [PLAY/STOP] button to play the recorded data.
2. ➔ Press the [PLAY/STOP] button again to stop playback.



If you press the [PLAY/STOP] button, but no recording exists, 'Empty' briefly appears in the display.

## 8.8 Songs for practising

The digital piano offers 60 songs for practising in total, where you mute the right hand voice and play this part yourself.

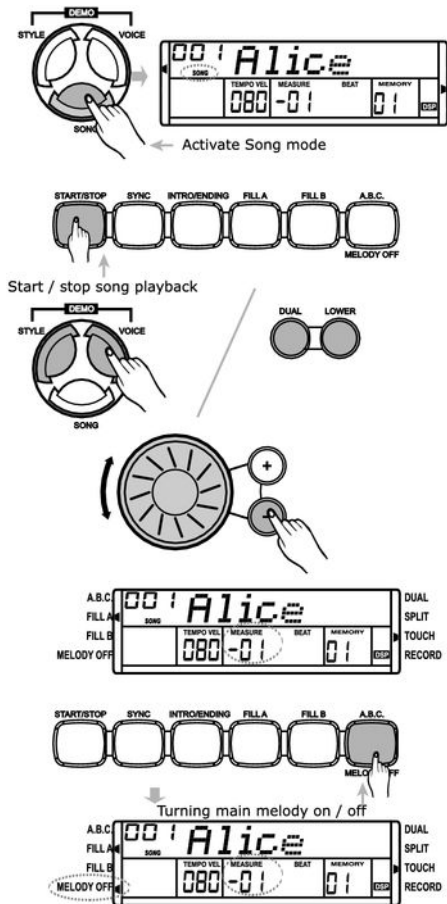

### 1. ▶ Playing and ending practising songs

Press the [SONG] button to enter the playback mode for practising songs. 'SONG' appears in the display. If you press the [SONG] button again all practising songs are played in an endless loop. If you press the [START/STOP] button the currently displayed practising song is played in an endless loop.

Press the [START/STOP] button again to end the currently played practising song. This will not quit the mode for practising song playback 'SONG'.

### 2. ▶ Selecting practising song

Use the jog wheel or the [+]/[-] buttons to select the desired practising song. When choosing a new practising song, the display shows the title.

### 3. ▶ Playback control

Prior to playback start, one beat is pre-counted. The beat display starts with a negative value. The practising song begins with beat 1.

### 4. ▶ Press the [START/STOP] button followed by one of the [STYLE], [VOICE], [DUAL] or [LOWER] buttons to stop playback and quit the mode for practising songs.

### 5. ▶ Press the [MELODY OFF] button to mute the right hand voice. 'MELODY OFF' lights up in the display and you only hear the left hand voice. Press the [MELODY OFF] button again to unmute the track.

## 9 Voice list

No.	Voice	No.	Voice	No.	Voice
001	Acoustic Grand Piano	031	Distortion Guitar	061	French Horn
002	Bright Acoustic Piano	032	Guitar Harmonics	062	Brass Section
003	Electric Grand Piano	033	Acoustic Bass	063	Synth Brass 1
004	Honky-Tonk Piano	034	Finger Bass	064	Synth Brass 2
005	Electric Piano 1	035	Pick Bass	065	Soprano Sax
006	Electric Piano 2	036	Fretless Bass	066	Alto Sax
007	Harpsichord	037	Slap Bass 1	067	Tenor Sax
008	Clavi	038	Slap Bass 2	068	Baritone Sax
009	Celesta	039	Synth Bass 1	069	Oboe
010	Glockenspiel	040	Synth Bass 2	070	English Horn
011	Music Box	041	Violin	071	Bassoon
012	Vibraphone	042	Viola	072	Clarinet
013	Marimba	043	Cello	073	Piccolo
014	Xylophone	044	Contrabass	074	Flute
015	Tubular Bells	045	Tremolo Strings	075	Recorder
016	Dulcimer	046	Pizzicato Strings	076	Pan Flute
017	Drawbar Organ	047	Orchestral Harp	077	Blown Bottle
018	Jazz Organ	048	Timpani	078	Shakuhachi
019	Rock Organ	049	StringsEnsemble 1	079	Whistle
020	Church Organ	050	StringsEnsemble	080	Ocarina
021	Reed Organ	051	Synth Strings 1	081	Square
022	Accordion	052	Synth Strings 2	082	Sawtooth
023	Harmonica	053	Choir Aahs	083	Calliope
024	Tango Accordion	054	Voice Oohs	084	Chiff
025	Nylon Guitar	055	Synth Voice	085	Charang
026	Steel Guitar	056	Orchestra Hit	086	Voice
027	Jazz Guitar	057	Trumpet	087	Fifths
028	Clean Guitar	058	Trombone	088	Bass Lead
029	Muted Guitar	059	Tuba	089	Fantasia
030	Overdriven Guitar	060	Muted Trumpet	090	Warm

## Voice list

No.	Voice	No.	Voice	No.	Voice
091	Poly Synth	122	Breath Noise	150	Soft Accordion
092	Choir	123	Seashore	151	Soft Accordion 2
093	Bowed	124	Bird Tweet	152	Harmonic
094	Metallic	125	Telephone Ring	<b>GIT &amp; BASS</b>	
095	Halo	126	Helicopter	153	N-Gthamm
096	Sweep	127	Applause	154	12Str Guitar
097	Fx1 (rain)	128	Gunshot	155	Clean Guitar 2
098	Fx2 (soundtrack)	<b>KEYBOARD</b>		156	Solidwa
099	Fx3 (crystal)	129	Pianostr	157	Overdriven Guitar 2
100	Fx4 (atmosphere)	130	Modern Electric Piano	158	Tremolo Guitar
101	Fx5 (brightness)	131	Solo Piano	159	Funk Guitar
102	Fx6 (goblins)	132	Polar	160	Bass Cymbal
103	Fx7 (echoes)	133	Grand Harpsi	161	Synth Bass 3
104	Fx8 (sci-fi)	134	Clavi 2	162	Synth Bass 4
105	Sitar	135	Bell	<b>STRINGS</b>	
106	Banjo	136	Bell 2	163	Viola 2
107	Shamisen	137	Vibes 2	164	Cello 2
108	Koto	138	Vibesma	165	Cello 3
109	Kalimba	139	Marimba 2	166	Strings Ensemble 3
110	Bag Pipe	<b>ORGAN</b>		167	Strings Ensemble 4
111	Fiddle	140	Electric Organ	168	Synth Strings 3
112	Shanai	141	Jazz Organ 2	169	Dream Strings
113	Tinkle Bell	142	Jazz Organ 3	<b>BRASS &amp; PIPE</b>	
114	Agogo	143	Clik Organ	170	Trombone 2
115	Steel Drums	144	Pop Organ	171	FM Horn
116	Wood Block	145	Church Organ 2	172	Bbbrass
117	Taiko Drum	146	Electric Organ 2	173	Hibrass
118	Melodic Tom	147	Tremolo Organ	174	Tenosax 2
119	Synth Drum	148	Q-Organ	175	Basso 2
120	Reverse Cymbal	<b>ACCORDION</b>		<b>LEAD</b>	
121	Guitar Fret Noise	149	Accordion 2	176	Whistle 2

No.	Voice	No.	Voice	No.	Voice
177	Pan Flute 2	<b>CHINESE INSTRUMENTS</b>		199	XIAO
178	Lead 1	188	Pi PA	<b>DRUM KIT</b>	
179	Lead 3	189	YUE QIN	200	Standard Drum 1
180	Warplead	190	MID RUAN	201	Standard Drum 2
<b>PAD</b>		191	GU ZHEN	202	Room Drum
181	Sinepad	192	YANG QIN	203	Rock Drum
182	Softpad	193	ER HU	204	Electric Drum
183	Bellpad	194	GAO HU	205	Analog Drumset
184	Synpad	195	SUO NA	206	Dance Drumset
185	Hornpad	196	LU SHEN	207	Jazz Drum
186	Newagpad	197	QU DI	208	Brush Drumset
187	Bagpipe	198	BANG DI	209	Standard Drumset
				210	Chinese Percussion

## 10 Styles list

No.	Style	No.	Style	No.	Style
<b>8 BEAT &amp; 16 BEAT</b>		028	Easy Ballad	055	Samba Funk
001	8 Beat	029	Love Ballad	056	Soul
002	Guitar Pop 1	030	Natural Ballad	057	Soul Beat
003	8 Beat Disco	031	Piano Ballad	058	Hip Hop Soul
004	8 Beat Dance	032	EP Ballad	059	British Soul Pop
005	60s 8 Beat	033	New R&B Ballad	060	Hip Hop Beat
006	Pop Funk	<b>ROCK</b>		061	R & B Ballad
007	16 Beat Ballad	034	Rock	<b>JAZZ</b>	
008	Pop 16 Beat 1	035	Folk Rock	062	Swing
009	Pop 16 Beat 2	036	Slow Rock 1	063	Jazz Brush
010	16 Beat Modern	037	Hard Rock	064	Cool Jazz Ballad
011	Modern 16 Beat	038	6/8 Rock	065	Acid Jazz 1
012	16 Beat Bossa Nova	039	Rock & Roll	066	Acid Jazz 2
013	16 Beat Funk	040	70's Rock & Roll	067	Big Band Medium
014	Cool Beat	041	Rock Shuffle	068	Big Band Ballad
<b>POP</b>		042	4/4 Blues	069	Swing Shuffle
015	Guitar Pop 2	<b>DANCE</b>		070	Fusion
016	Pop beat	043	Club Dance	071	Jazz Fusion
017	Soft beat	044	Disco	<b>COUNTRY</b>	
018	Sting Latin	045	70's Disco Funk	072	Country 8 Beat
019	Brit Pop 1	046	Garage	073	Country Pop 1
020	Brit Pop 2	047	Rap 1	074	Country Ballad
021	New Age	048	Rap 2	075	Modern Country
022	Pop Hit	049	House	076	Country Folk
023	Fusion Shuffle	050	Euro Dance	077	2/4 Country
<b>BALLAD</b>		051	Techno	078	Country Pop 2
024	Folk Ballad	<b>SOUL &amp; FUNK</b>		079	Country Shuffle
025	Pop Ballad 1	052	Jazz Funk	080	Country Quick Steps
026	Pop Ballad 2	053	Cool Funky	081	Bluegrass
027	Rock Ballad	054	Groove		



No.	Style	No.	Style	No.	Style
<b>LATIN/BALLROOM</b>		<b>TRADITIONAL</b>		108	Slow Rock 2
082	Bossa Nova 1	096	March	109	Bossa Nova 2
083	Rhumba	097	German March	110	Twist
084	Cha Cha Cha	098	6/8 March	<b>INDONESIA</b>	
085	Pop Cha Cha	099	Polka	111	Dandut 1
086	Beguine	100	Polka Pop 1	112	Dandut 2
087	Tango	101	Polka Pop 2	113	Dangdu
088	Swing Fox	102	Slow Waltz	114	Dangdut 1
089	Mambo	103	Country Waltz	115	Dangdut 2
090	Salsa	104	Jazz Waltz	116	Dangdut 3
091	Samba	105	Musette	117	Kercong 1
092	Pasodoble	<b>PIANO</b>		118	Kercong 2
093	Slow Bolero	106	Pianist	119	PopKcong
094	Habanera	107	Ballad	120	Sdangdut
095	Latin Rock				

## 11 Practice and demo songs

No.	Title	No.	Title
<b>PIANO</b>		027	Edelweiss
001	For Alice	028	O Sole Mio
002	Habanera	029	Silent Night
003	Four Little Swans	030	Ave Maria
004	Moseta Dance	031	Five Hundred Miles
005	Germanic Dance	032	Happy New Year
006	Turkish March	033	It's Beginning To Look A Lot Like Christmas
007	March	034	Jeanie With The Light Brown Hair
008	Away In A Manger	035	My Bonnie
009	Chopsticks	036	Song Of The Pearlfisher
010	2-Part Invention # 13 In A Minor. BWV 784	037	The Stage Coach
<b>FOLK &amp; COUNTRY</b>		038	Entertainer
011	Country	039	Annie Laurie
012	Jambalaya	040	Kiling Me Softly With His Song
013	Susanna	041	Last Rose Of Summer
014	Bridge	042	The Old King Cole
015	Battle Hymne Of The Republic	<b>JAZZ &amp; FUSION</b>	
016	The Old Gray Mare	043	Maple Leaf Rag
017	American Patrol	044	June Samba
018	In The Rain	045	Funk
019	Sippin' Cider Through A Straw	046	I Can....
<b>GOLDEN &amp; POP</b>		047	Sea Shore
020	Are You Lonesome Tonight	048	Guitar & Saxophone
021	Only You	049	The Hip Hop's Night
022	End Of The World	050	Blue Lunch
023	House Of Rising Sun	051	Cobweb
024	The Blues-Bells Of Scotland	052	Wine
025	Over The Rainbow	053	Jazz Old Man
026	Beautiful Dreamer	054	Dark Eyes

---

No.	Title	No.	Title
055	Carlos	<b>CHINESE</b>	
056	Sad	058	South Mud Bay
057	The Jazz	059	Give You A Rose
		060	Flowing Rill

**Demo songs**

No.	Name
001	DEMO 1
002	DEMO 2
003	DEMO 3

## 12 Chord list

	Chord description	Normal chord construction	Chord symbol	Display
0	Major [M]	1-3-5	C	C
1	Major sixth [6]	1-(3)-5-6	C6	C6
2	Major seventh [M7]	1-3-(5)-7	CM7	CM7
3	Major seventh with augmented eleventh [M7#11]	1-(2)-3-#4-(5)-7	CM7#11	CM7(#11)
4	Major add ninth [Madd9]	1-2-3-5	CMadd9	CM(9)
5	Major ninth [M9]	1-2-3-(5)-7	CM9	CM7(9)
6	Major sixth and ninth [6 9]	1-2-3-(5)-6	C6 9	C6(9)
7	Augmented [aug]	1-3-#5	Caug	Caug
8	Minor [m]	1-b3-5	Cm	Cm
9	Minor sixth [m6]	1-b3-5-6	Cm6	Cm6
10	Minor seventh [m7]	1-b3-(5)-b7	Cm7	Cm7
11	Minor seventh flatted fifth [m7b5]	1-b3-b5-b7	Cm7b5	Cm7(b5)
12	Minor add ninth [madd9]	1-2-b3-5	Cmadd9	Cm(9)
13	Minor ninth [m9]	1-2-b3-(5)-b7	Cm9	Cm7(9)
14	Minor eleventh [m11]	1-(2)-b3-4-5-(b7)	Cm11	Cm7(11)
15	Minor major ninth [mM7]	1-b3-(5)-7	CmM7	CmM7
16	Minor major ninth [mM9]	1-2-b3-(5)-7	CmM9	CmM7(9)
17	Diminished [dim]	1-b3-b5	Cdim	Cdim
18	Diminished seventh [dim7]	1-b3-b5-6	Cdim7	Cdim7
19	Seventh [7]	1-3-(5)-b7	C7	C7
20	Seventh suspended [7sus4]	1-4-5-b7	C7sus4	C7sus4
21	Seventh flatted fifth [7b5]	1-3-b5-b7	C7b5	C7(b5)
22	Seventh ninth [79]	1-2-3-(5)-b7	C7 9	C7(9)
23	Seventh sharp eleventh [7#11]	1-2-3-#4-(5)-b7 or 1-(2)-3-#4-5-b7	C7#11	C7(#11)
24	Seventh thirteenth [7 13]	1-3-(5)-6-b7 or 2-3-5-6-b7	C7 13	C7(13)
25	Seventh flatted ninth [7b9]	1-b2-3-(5)-b7	C7b9	C7(b9)
26	Seventh flatted thirteenth [7b13]	1-3-5-b6-b7	C7b13	C7(b13)
27	Seventh sharp ninth [7#9]	(1)-#2-3-(5)-b7	C7#9	C7(#9)
28	Major seventh augmented [M7aug]	1-3-#5-7	CM7aug	CM7aug
29	Seventh augmented [7aug]	(1)-3-#5-b7	C7aug	C7aug

---

	<b>Chord description</b>	<b>Normal chord construction</b>	<b>Chord symbol</b>	<b>Display</b>
30	Suspended fourth [sus4]	1-4-5	Csus4	Csus4
31	Suspended second [1+2+5]	1-2-5	C1+2+5	C

## 13 MIDI implementation chart

Function		Transmitted	Received	Remarks
Basic channel	Default	1	1-16	
	Changed	1-16	1-16	
Mode	Default	No	Mode 3	
	Messages	No	No	
	Altered	*****	No	
Note number		9 – 120	0 – 127	
	True voice	*****	0 – 127	
Velocity note	Note ON	Yes, 9nH, v = 1 127	Yes, 9nH, v = 1 127	
	Note OFF	No, 9nH, v = 0	No, 9nH, v = 0	
After touch	Keys	No	No	
	Channels	No	No	
Pitch bend		Yes	Yes	
Control change	0	Yes	Yes	Bank select
	1	Yes	Yes	Modulation
	5	No	Yes	Portamento time
	6	Yes	Yes	Data entry
	7	Yes	Yes	Volume
	10	No	Yes	Pan
	11	No	Yes	Expression
	64	Yes	Yes	Sustain pedal
	65	No	Yes	Portamento ON/OFF
	66	No	Yes	Sostenuto pedal
	67	Yes	Yes	Soft pedal
	80	Yes	Yes	Reverb program
	81	Yes	Yes	Chorus program
	91	Yes	Yes	Reverb level
	93	Yes	Yes	Chorus level
	120	No	Yes	All sound off
121	No	Yes	Reset all controllers	
123	Yes	Yes	All notes off	

Function		Transmitted	Received	Remarks
Program change	True #	Yes *****	Yes 0 – 127	
System exclusive		No	Yes	
System common	Song position pointer	No	No	
	Song select	No	No	
	Tune request	No	No	
System real time	Clock	No	No	
	Commands	No	No	
Aux messages	Local ON/OFF	No	No	
	ALL notes OFF	Yes	Yes	
	Active sensing	No	Yes	
	System reset	No	Yes	
Notes:	<p>*1</p> <p>When the accompaniment starts, an FAH message is transmitted.</p> <p>When the accompaniment stops, an FCH message is transmitted.</p> <p>When an FAH message is received, the accompaniment starts.</p> <p>When an FCH message is received, the accompaniment stops.</p>			

**MIDI channel mode**

	POLY	MONO ON
OMNI ON	Mode 1	Mode 2
OMNI OFF	Mode 3	Mode 4

## 14 Technical specifications

Keyboard	88 weighted keys with hammer action and adjustable touch velocity
Instrument voices	210
Styles	120
Demo and practise songs	3 demo and 60 practise songs
Polyphony	64-voiced (without DSP effect), 38-voiced (with DSP effect)
Display	Multifunctional LCD with blue backlight
Switches and buttons	[POWER], [VOLUME], [AUTO BASS CHORD], [MELODY OFF], [ACC. VOL +/-], [TEMPO +/-], [FUNCTION], [MIXER], [METRONOME], [DEMO], [SONG], [VOICE], [STYLE], [+/-], [BANK], [STORE (M1-M4)], [ONE TOUCH SETTING], [DUAL], [SPLIT], [RECORD], [PLAY/STOP]
Accompaniment	[START/STOP], [SYNC START], [INTRO/ENDING], [FILL A], [FILL B]
Recording	[RECORD], [PLAY/STOP]
Memory	4 banks with 4 memory slots each
MIDI	Receive / send
Connections	Supply voltage AC 230 V ~ , 2 x headphones (1/4" phone sockets), AUX OUT (L/R), USB, MIDI IN, MIDI OUT, three pedals (soft, sostenuto and sustain)
Speakers	8 Ω, 2 x 25 W
Dimensions (W x D x H)	1419 mm x 473 mm x 855 mm
Weight	47 kg



## 15 Protecting the environment

### Disposal of the packaging material



For the transport and protective packaging, environmentally friendly materials have been chosen that can be supplied to normal recycling.

Ensure that plastic bags, packaging, etc. are properly disposed of.

Do not just dispose of these materials with your normal household waste, but make sure that they are collected for recycling. Please follow the notes and markings on the packaging.

### Disposal of your old device



This device is subject to the European directive 2002/96/EC.

Do not dispose of the device with your normal household waste.

Dispose of this device through an approved waste disposal firm or through your local waste facility. When discarding the device, comply with the rules and regulations that apply in your country. If in doubt, consult your local waste disposal facility.





