



STARVILLE

MH-z720 Quad
LED Wash Zoom
moving head

Musikhaus Thomann

Hans-Thomann-Straße 1

96138 Burgebrach

Germany

Telephone: +49 (0) 9546 9223-0

E-mail: info@thomann.de

Internet: www.thomann.de

30.06.2015, ID: 350087

Table of contents

1	General notes	5
	1.1 Further information.....	6
	1.2 Notational conventions.....	7
	1.3 Symbols and signal words.....	8
2	Safety instructions	10
3	Features	16
4	Installation	17
5	Starting up	22
6	Connections and operating elements	25
7	Operating	28
	7.1 Starting the device.....	28
	7.2 Main menu.....	29
	7.3 Address setting menu.....	30
	7.4 Mode selecting menu.....	31
	7.5 Device settings menu.....	33

7.6	Device information menu.....	41
7.7	Menu overview.....	42
7.8	Settings menu.....	45
7.9	Menu overview (settings menu).....	47
7.10	Functions in 14-channel DMX mode.....	48
7.11	Functions in 29-channel DMX mode.....	55
8	Technical specifications.....	69
9	Plug and connection assignments.....	70
10	Troubleshooting.....	71
11	Cleaning.....	74
12	Protecting the environment.....	75

1 General notes

This manual contains important instructions for the safe operation of the unit. Read and follow the safety instructions and all other instructions. Keep the manual for future reference. Make sure that it is available to all those using the device. If you sell the unit please make sure that the buyer also receives this manual.

Our products are subject to a process of continuous development. Thus, they are subject to change.

1.1 Further information

On our website (www.thomann.de) you will find lots of further information and details on the following points:

Download	This manual is also available as PDF file for you to download.
Keyword search	Use the search function in the electronic version to find the topics of interest for you quickly.
Online guides	Our online guides provide detailed information on technical basics and terms.
Personal consultation	For personal consultation please contact our technical hotline.
Service	If you have any problems with the device the customer service will gladly assist you.

1.2 Notational conventions

This manual uses the following notational conventions:

Letterings

The letterings for connectors and controls are marked by square brackets and italics.

Examples: *[VOLUME]* control, *[Mono]* button.

Displays

Texts and values displayed on the device are marked by quotation marks and italics.

Examples: *'24ch'*, *'OFF'*.

Cross-references



References to other locations in this manual are identified by an arrow and the specified page number. In the electronic version of the manual, you can click the cross-reference to jump to the specified location.

Example: See ↗ *'Cross-references'* on page 7.

1.3 Symbols and signal words

In this section you will find an overview of the meaning of symbols and signal words that are used in this manual.

Signal word	Meaning
DANGER!	This combination of symbol and signal word indicates an immediate dangerous situation that will result in death or serious injury if it is not avoided.
WARNING!	This combination of symbol and signal word indicates a possible dangerous situation that can result in death or serious injury if it is not avoided.
CAUTION!	This combination of symbol and signal word indicates a possible dangerous situation that can result in minor injury if it is not avoided.
NOTICE!	This combination of symbol and signal word indicates a possible dangerous situation that can result in material and environmental damage if it is not avoided.

Warning signs	Type of danger
 A yellow triangular warning sign with a black border and a black lightning bolt symbol in the center, indicating high voltage.	Warning – high-voltage.
 A yellow triangular warning sign with a black border and a black symbol of a person standing next to a suspended load, indicating a suspended load.	Warning – suspended load.
 A yellow triangular warning sign with a black border and a black exclamation mark in the center, indicating a general danger or hazard.	Warning – danger zone.

2 Safety instructions

Intended use

This device is intended to be used as moving-head spotlight. The device is designed for professional use and is not suitable for use in households. Use the device only as described in this user manual. Any other use or use under other operating conditions is considered to be improper and may result in personal injury or property damage. No liability will be assumed for damages resulting from improper use.

This device may be used only by persons with sufficient physical, sensorial, and intellectual abilities and having corresponding knowledge and experience. Other persons may use this device only if they are supervised or instructed by a person who is responsible for their safety.

Safety**DANGER!****Danger for children**

Ensure that plastic bags, packaging, etc. are disposed of properly and are not within reach of babies and young children. Choking hazard!

Ensure that children do not detach any small parts (e.g. knobs or the like) from the unit. They could swallow the pieces and choke!

Never let children unattended use electrical devices.

**DANGER!****Electric shock caused by high voltages inside**

Within the device there are areas where high voltages may be present. Never remove any covers.

There are no user-serviceable parts inside.

Do not use the device if covers, protectors or optical components are missing or damaged.



DANGER!

Electric shock caused by short-circuit

Always use proper ready-made insulated mains cabling (power cord) with a protective contact plug. Do not modify the mains cable or the plug. Failure to do so could result in electric shock/death or fire. If in doubt, seek advice from a registered electrician.



WARNING!

Eye damage caused by high light intensity

Never look directly into the light source.



WARNING!

Risk of epileptic shock

Strobe lighting can trigger seizures in photosensitive epilepsy. Sensitive persons should avoid looking at strobe lights.



WARNING!

Risk of injury by falling off

Make sure that the installation complies with the standards and rules that apply in your country. Always secure the device with a secondary safety attachment, such as a safety cable or a safety chain.

The carrying capacity of the truss or other mounting must be sufficient for the intended number of devices. Note that the movement of the head may additionally stress the load-bearing structures.



CAUTION!

Risk of injury due to movements of the device

The head of the device can move quickly (pan, tilt) and can produce very bright light. This is also valid immediately after you turn on the device, when the device operates in automatic mode or under remote control and when you turn off a DMX controller that is connected to the device. Persons staying near the device could be injured or frightened.

Before you turn on the device and during the operation, always ensure that nobody stays close to the device. If work has to be performed in the area of movement or in the near vicinity of the device, it must remain turned off.



NOTICE!

Risk of fire

Do not cover the device nor any ventilation slots. Do not place the device near any direct heat source. Keep the device away from naked flames.



NOTICE!

Operating conditions

This device has been designed for indoor use only. To prevent damage, never expose the device to any liquid or moisture. Avoid direct sunlight, heavy dirt, and strong vibrations.

The device must not be moved while it is in use.



NOTICE!

Power supply

Before connecting the device, ensure that the input voltage (AC outlet) matches the voltage rating of the device and that the AC outlet is protected by a residual current circuit breaker. Failure to do so could result in damage to the device and possibly injure the user.

Unplug the device before electrical storms occur and when it is unused for long periods of time to reduce the risk of electric shock or fire.

3 Features

The moving head is particularly suitable for professional lighting tasks, for example at events, on rock stages, in theatres and musicals or in discotheques.

Special features of the device:

- 7 four-colour LEDs (RGBW, 20 W each)
- Control via DMX (14 or 29 channels) and via buttons and high-resolution colour display on the unit
- Preprogrammed automatic show programmes
- Sound control
- Master / Slave mode
- Strobe effect
- Electronic dimmer
- Robust housing with two integrated carrying handles
- Zoom optics provides high colour fidelity in all mixing and zooming
- Mounting bracket and safety cable eyelet supplied

4 Installation

Unpack and carefully check that there is no transportation damage before using the unit. Keep the equipment packaging. To fully protect the device against vibration, dust and moisture during transportation or storage use the original packaging or your own packaging material suitable for transport or storage, respectively.

Lift the device only at the base. When lifted at the rotatable mounting, the device may be damaged.

You can install the device standing or hanging. When in use, the device must be mounted at a solid surface or clamped to an approved truss.

Work from a stable platform whenever you install or move the device or when you perform any kind of maintenance. Block access under the work area.



WARNING!

Risk of injury by falling off

Make sure that the installation complies with the standards and rules that apply in your country. Always secure the device with a secondary safety attachment, such as a safety cable or a safety chain.

The carrying capacity of the truss or other mounting must be sufficient for the intended number of devices. Note that the movement of the head may additionally stress the load-bearing structures.



NOTICE!

Risk of overheating

Always ensure sufficient ventilation.

The ambient temperature must always be below 40 °C (104 °F).



NOTICE!

Possible data transmission errors

For error-free operation make use of dedicated DMX cables and do not use ordinary microphone cables.

Never connect the DMX input or output to audio devices such as mixers or amplifiers.

Mounting options

The threads on the case bottom are used for secure mounting. Either the supplied mounting bracket or flight adapters (half coupler, trigger clamps, C-hooks, etc.) can be attached to the two opposite threads (B). The third thread on the case bottom (A) is provided for the supplied safety cable eyelet. The safety cable must be guided through this safety eyelet.

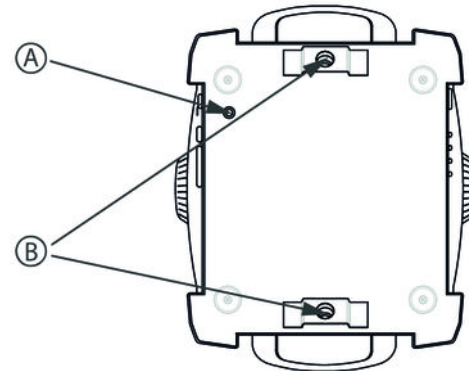

A	Thread for safety cable eyelet
B	Thread for supplied mounting bracket or flight adapters (half coupler, trigger clamps, C-hooks, etc.)

5 Starting up

Establish all connections as long as the unit is switched off. Use the shortest possible high-quality cables for all connections.

Connections in DMX mode

Connect the DMX input of the device to the DMX output of a DMX controller or another DMX device. Connect the output of the first DMX device to the input of the second one, and so on to form a daisy chain. Always ensure that the output of the last DMX device in the daisy chain is terminated with a resistor ($110\ \Omega$, $\frac{1}{4}\text{ W}$).

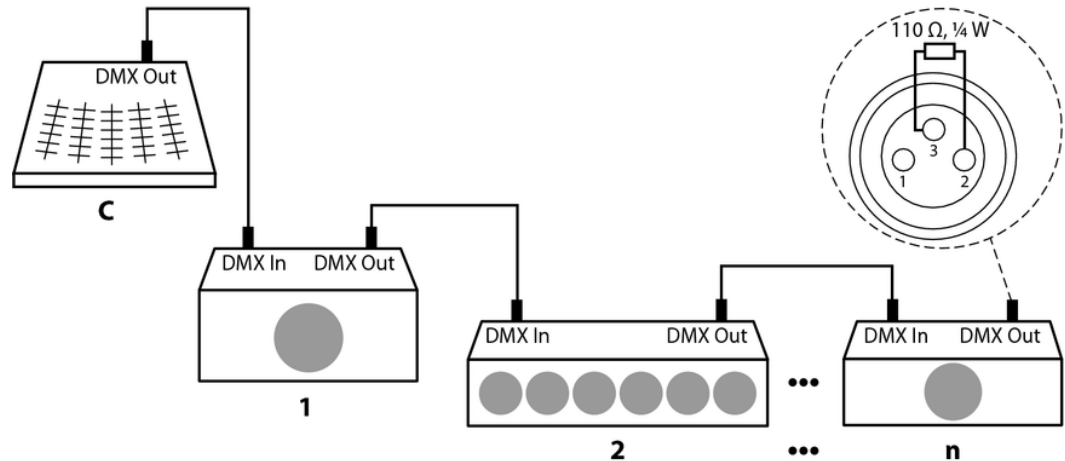

The flashing 'DMX' LED indicates an incoming DMX signal.

Connections in master/slave mode

When you configure a group of devices in master/slave mode, the first unit will control the other units for an automatic, sound-activated, synchronized show. This function is ideal when you want to start a show immediately. Connect the DMX output of the master device to the DMX input of the first slave device. Then connect the DMX output of the first slave device to the DMX input of the second slave device and so on.

6 Connections and operating elements

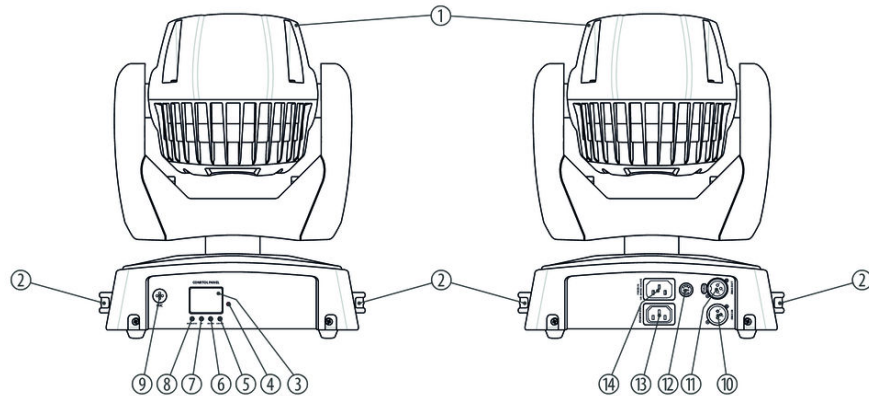

1 Spotlight head with LEDs.

2 Carrying handles.

MH-z720 Quad LED Wash Zoom

3	Display.
4	DMX indicator. Displays the selected mode when the main menu is closed.
5	<i>[ENTER]</i> Selects an option of the respective operating mode.
6	<i>[DOWN]</i> Decreases the displayed value by one.
7	<i>[UP]</i> Increases the displayed value by one.
8	<i>[MODE/ESC]</i> Activates the main menu and toggles between menu items. Closes an open sub-menu without saving any changes.
9	Microphone for sound control.
10	<i>[DMX IN]</i> DMX input.

11	<i>[DMX OUT]</i> DMX output.
12	Fuse holder. If the fuse blows, replace it with a new fuse of the same type. You must first disconnect the device from the power supply.
13	<i>[POWER OUT]</i> IEC chassis socket for the power supply cable to the next unit.
14	<i>[POWER IN]</i> IEC chassis plug for the power supply.

7 Operating

7.1 Starting the device



CAUTION!

Risk of injury due to movements of the device

The head of the device can move quickly (pan, tilt) and can produce very bright light. This is also valid immediately after you turn on the device, when the device operates in automatic mode or under remote control and when you turn off a DMX controller that is connected to the device. Persons staying near the device could be injured or frightened.

Before you turn on the device and during the operation, always ensure that nobody stays close to the device. If work has to be performed in the area of movement or in the near vicinity of the device, it must remain turned off.

Connect the device to the power supply to start operation. After a few seconds, the fans start to work, the head moves to the home positions for rotation (pan) and inclination (tilt). After a few more seconds, the display shows the last set operating status. Now the device is then ready for use.

7.2 Main menu

Press *[MODE/ESC]* to activate the main menu. Press *[UP]* and *[DOWN]* to select a main menu option and *[ENTER]* to open the selected option.

Use *[UP]* and *[DOWN]* to change the respectively indicated value. When the desired value is shown or highlighted in the display, press *[ENTER]*. To return to the parent menu without making changes, press *[MODE/ESC]*.

If you don't press any button for about 30 seconds the display turns off. Then press *[MODE/ESC]* briefly to turn it on again. The display will then show the selected mode.

All previous settings are retained even when you switch the device off and disconnect it from the mains. To restart with default values, use the function 'Factory Set' (↩ 'Loading default values' on page 41).

7.3 Address setting menu

DMX address

Select the option 'Address' from the main menu. Now you can set the number of the first DMX channel to be used by the device (DMX address). Use *[UP]* and *[DOWN]* to select a value between 1 and 512.

When the display shows the desired value press *[ENTER]* to confirm the setting and then *[MODE/ESC]* to return to the main menu. To close the menu item without making changes, press *[MODE/ESC]*.

Make sure that this number matches the configuration of your DMX controller. The following table shows the highest possible DMX address for the various DMX modes

Mode	Highest possible DMX address
14 channels	499
29 channels	484

7.4 Mode selecting menu

Operating mode 'DMX'

This setting is only relevant if the device is controlled via DMX.

Select the option *'Run Mode'* from the main menu. The mode selecting menu opens up. Use *[UP]* and *[DOWN]* to select the option *'DMX'*. Press *[ENTER]* to open this menu item. With *[UP]* and *[DOWN]* you can now select one of the following DMX operating modes:

- *'14CH'* (14 channels)
- *'29ch'* (29 channels)

When the display shows the desired value press *[ENTER]* to confirm the setting and then *[MODE/ESC]* to return to the main menu. To close the menu item without making changes, press *[MODE/ESC.]*

Operating mode 'Preprogrammed automatic show'

A preprogrammed automatic show can only be activated when the unit is operating in stand-alone mode or as master in a master / slave combination. This setting is only relevant if the device is not controlled via DMX.

Select the option *'Run Mode'* from the main menu. The mode selecting menu opens up. Use *[UP]* and *[DOWN]* to select the option *'Auto'*. Press *[ENTER]* to open this menu item. With *[UP]* and *[DOWN]* you can now select one of 16 automatic shows. When the display shows the desired value press *[ENTER]* to confirm the setting and then *[MODE/ESC]* to return to the main menu. To close the menu item without making changes, press *[MODE/ESC]*.

Sound control

The sound controlled automatic show can only be activated when the unit is operating in stand alone mode or as master in a master / slave combination. This setting is only relevant if the device is not controlled via DMX.

Select the option *'Run Mode'* from the main menu. The mode selecting menu opens up. Use *[UP]* and *[DOWN]* to select the option *'Sound'* and press *[ENTER]* to start the sound-controlled automatic show.

Operating mode 'Slave'

This setting is only relevant if the device is working as Slave in a Master / Slave configuration and is not controlled via DMX.

Select the option *'Run Mode'* from the main menu. The mode selecting menu opens up. Use *[UP]* and *[DOWN]* to select the option *'Slave'* and press *[ENTER]*. The device is now controlled by another connected device, which is configured as Master.

7.5 Device settings menu

Pan inversion

Select the option *'Setup'* from the main menu. The Device settings menu opens up. Use *[UP]* and *[DOWN]* to select the option *'Pan Reverse'* and press *[ENTER]*. With *[UP]* and *[DOWN]* you can now choose between *'ON'* (reverse rotational direction) and *'OFF'* (normal rotational direction).

When the display shows the desired value press *[ENTER]* to confirm the setting and then *[MODE/ESC]* to return to the main menu. To close the menu item without making changes, press *[MODE/ESC]*.

Tilt inversion

Select the option *'Setup'* from the main menu. The Device settings menu opens up. Use *[UP]* and *[DOWN]* to select the option *'Tilt Reverse'* and press *[ENTER]*. With *[UP]* and *[DOWN]* you can now choose between *'ON'* (reverse direction of inclination) and *'OFF'* (normal direction of inclination).

When the display shows the desired value press *[ENTER]* to confirm the setting and then *[MODE/ESC]* to return to the main menu. To close the menu item without making changes, press *[MODE/ESC]*.

Pan area

Select the option *'Setup'* from the main menu. The Device settings menu opens up. Use *[UP]* and *[DOWN]* to select the option *'Pan Angle'* and press *[ENTER]*. With *[UP]* and *[DOWN]* you can now select between *'540'* (Pan range = 540°), *'360'* (Pan range = 360°) and *'180'* (Pan range = 180°).

When the display shows the desired value press *[ENTER]* to confirm the setting and then *[MODE/ESC]* to return to the main menu. To close the menu item without making changes, press *[MODE/ESC]*.

Tilt area

Select the option *'Setup'* from the main menu. The Device settings menu opens up. Use *[UP]* and *[DOWN]* to select the option *'Tilt Angle'* and press *[ENTER]*. With *[UP]* and *[DOWN]* you can now select between *'270'* (Pan range = 270°), *'180'* (Pan range = 180°) and *'90'* (Pan range = 90°).

When the display shows the desired value press *[ENTER]* to confirm the setting and then *[MODE/ESC]* to return to the main menu. To close the menu item without making changes, press *[MODE/ESC]*.

Motor speed

Select the option *'Setup'* from the main menu. The Device settings menu opens up. Use *[UP]* and *[DOWN]* to select the option *'P/T Speed'* and press *[ENTER]*. With *[UP]* and *[DOWN]* you can now select between *'Slow'* (low speed for Pan and Tilt), *'Normal'* (medium speed) and *'Fast'* (high speed).

When the display shows the desired value press *[ENTER]* to confirm the setting and then *[MODE/ESC]* to return to the main menu. To close the menu item without making changes, press *[MODE/ESC]*.

Fan control

Select the option *'Setup'* from the main menu. The Device settings menu opens up. Use *[UP]* and *[DOWN]* to select the option *'Fans'* and press *[ENTER]*. With *[UP]* and *[DOWN]* you can now select between *'Auto'* (automatic fan speed control depending on device temperature) and *'Full'* (maximum fan speed).

When the display shows the desired value press *[ENTER]* to confirm the setting and then *[MODE/ESC]* to return to the main menu. To close the menu item without making changes, press *[MODE/ESC]*.

Display on time

Select the option *'Setup'* from the main menu. The Device settings menu opens up. Use *[UP]* and *[DOWN]* to select the option *'Display'* and press *[ENTER]*. With *[UP]* and *[DOWN]* you can now select between *'ON'* (display constantly on) and *'OFF'* (displays turns off after 30 seconds without any key press).

When the display shows the desired value press *[ENTER]* to confirm the setting and then *[MODE/ESC]* to return to the main menu. To close the menu item without making changes, press *[MODE/ESC]*.

Display reversal

Select the option *'Setup'* from the main menu. The Device settings menu opens up. Use *[UP]* and *[DOWN]* to select the option *'Screen Rev'* and press *[ENTER]*. With *[UP]* and *[DOWN]* you can now select between *'ON'* (mirrored display for overhead mounting) and *'OFF'* (normal display).

When the display shows the desired value press *[ENTER]* to confirm the setting and then *[MODE/ESC]* to return to the main menu. To close the menu item without making changes, press *[MODE/ESC]*.

Dimmer curve

This setting is only relevant if the device is controlled via DMX.

Select the option *'Setup'* from the main menu. The Device settings menu opens up. Use *[UP]* and *[DOWN]* to select the option *'Dimmer Curve'* and press *[ENTER]*. With *[UP]* and *[DOWN]* you can now select one of the following dimmer curves: The dimmer curve determines how the brightness increases or decreases depending on the set DMX value.

When the display shows the desired value press *[ENTER]* to confirm the setting and then *[MODE/ESC]* to return to the main menu. To close the menu item without making changes, press *[MODE/ESC]*.

Display	Description
<i>'Linear'</i>	Linear (proportional) course
<i>'SCurve'</i>	Non-linear curve with a distinctive flat profile at the beginning and end
<i>'ISqua'</i>	Inverted quadratic curve with a steep profile at the beginning and flat profile at the end
<i>'Square'</i>	Inverted square curve with a steep profile at the beginning and flat profile at the end

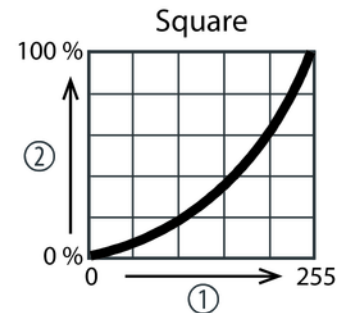
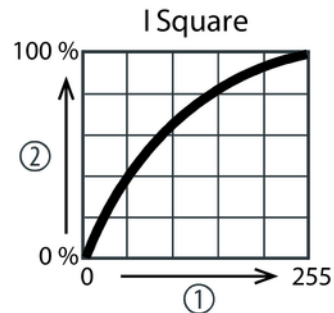
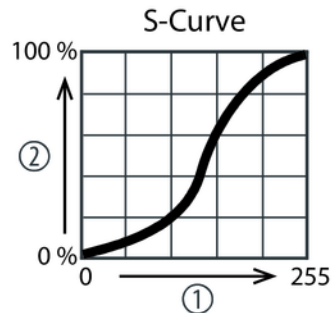
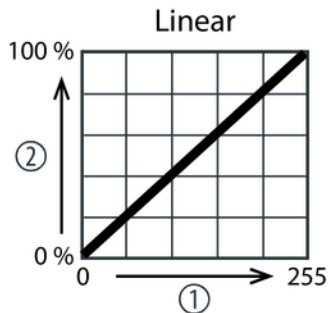

Dimmer speed

Select the option *'Setup'* from the main menu. The Device settings menu opens up. Use *[UP]* and *[DOWN]* to select the option *'Dimmer Speed'* and press *[ENTER]*. With *[UP]* and *[DOWN]* you can now select one of the following dimmer speed values: *'Fast'* or *'Smooth'* (slow).

When the display shows the desired value press *[ENTER]* to confirm the setting and then *[MODE/ESC]* to return to the main menu. To close the menu item without making changes, press *[MODE/ESC]*.

White balance

Select the option *'Setup'* from the main menu. The Device settings menu opens up. Use *[UP]* and *[DOWN]* to select the option *'Color Balance'* and press *[ENTER]*. With *[UP]* and *[DOWN]* you can now select the primary colour you want to set: *'RED'*, *'GREEN'*, *'BLUE'*, *'WHITE'*. Press again *[ENTER]*. With *[UP]* and *[DOWN]* you can now set a value between 100 and 255 for the selected colour.

When the display shows the desired value press *[ENTER]* to confirm the setting and then *[MODE/ESC]* to return to the main menu. To close the menu item without making changes, press *[MODE/ESC]*.

Microphone sensitivity

Select the option *'Setup'* from the main menu. The Device settings menu opens up. Use *[UP]* and *[DOWN]* to select the option *'Sensitivity'* and press *[ENTER]*. With *[UP]* and *[DOWN]* you can now set the sensitivity for the sound control: Use *[UP]* and *[DOWN]* to select a value between 1 (low sensitivity) and 100 (high sensitivity).

When the display shows the desired value press *[ENTER]* to confirm the setting and then *[MODE/ESC]* to return to the main menu. To close the menu item without making changes, press *[MODE/ESC]*.

System reset

Select the option *'Setup'* from the main menu. The Device settings menu opens up. Use *[UP]* and *[DOWN]* to select the option *'Reset'* and press *[ENTER]* to reset all movable axes to their home positions.

Loading default values

Select the option *'Setup'* from the main menu. The Device settings menu opens up. Use *[UP]* and *[DOWN]* to select the option *'Factory Set'* and press *[ENTER]* to reset all values to their factory default settings.

7.6 Device information menu

Select the option *'System Information'* from the main menu. The display shows the following information.

- *'Ver'*: Software version of the device
- *'Running Mode'*: Operating mode (DMX, Auto, Sound or Slave)
- *'DMX Address'*: Set DMX address
- *'Temperature'*: Current device temperature

Press *[MODE/ESC]* or *[ENTER]* to quit the menu.

7.7 Menu overview

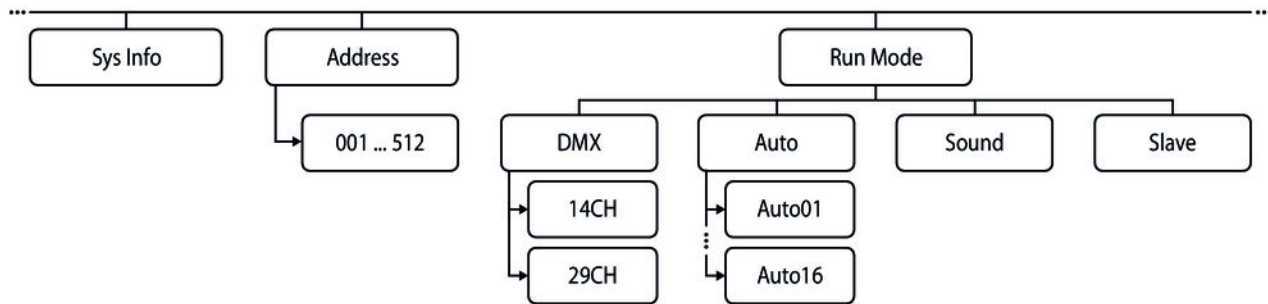

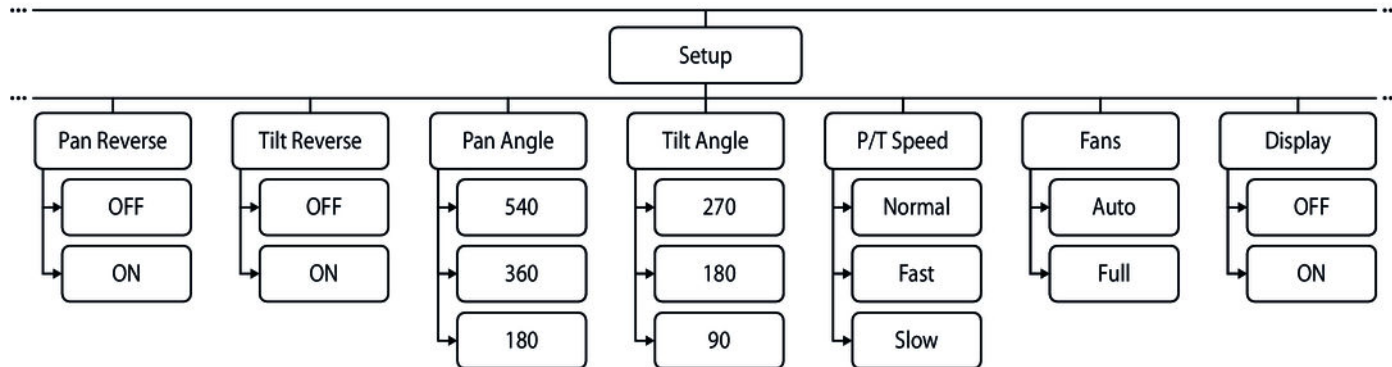

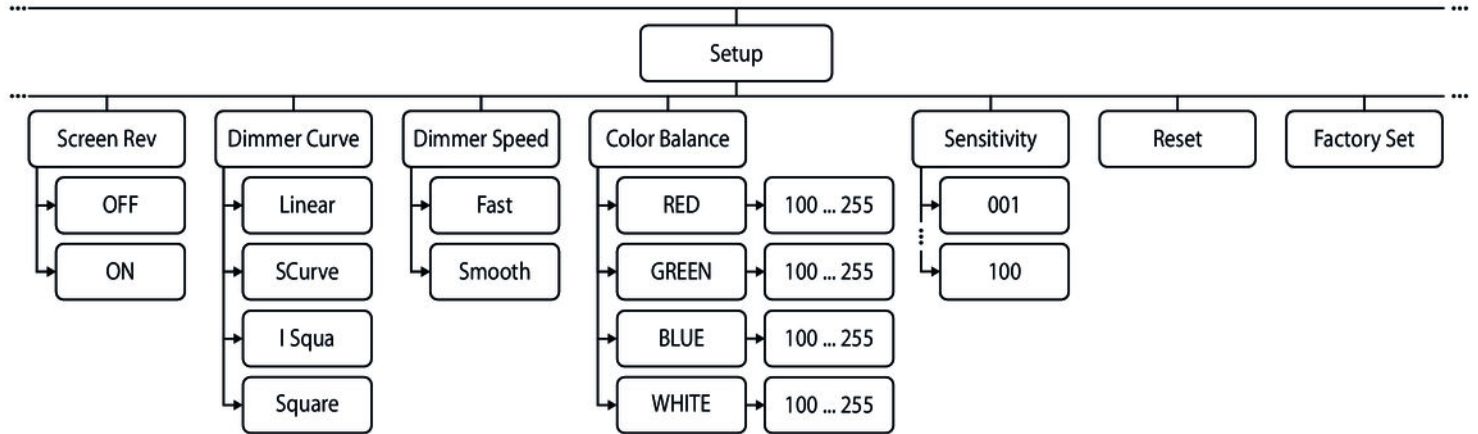

7.8 Settings menu

Press *[MODE/ESC]* for at least five seconds to enable the settings menu. Use *[UP]* or *[DOWN]* to enter the password 2323 for the device. At that, the button *[UP]* changes the digit in the cursor position, the button *[DOWN]* moves the cursor to the next position. Press *[ENTER]* when all digits are entered.

Press *[MODE/ESC]* twice to quit the settings menu.

All settings done here are retained even when you disconnect the device from the mains.

Rotation (alignment)

Activate the settings menu. Press *[UP]* and *[DOWN]* until the top row of the display 'Pan' flashes. Press *[ENTER]* to open this menu item. Use the buttons *[UP]* or *[DOWN]* to adjust the desired home position.

When the display shows the desired value press *[ENTER]* to confirm the setting and then *[MODE/ESC]* to change to the next menu item. To change the menu item without making changes, press *[MODE/ESC]*.

Inclination (alignment)

Activate the settings menu. Press *[UP]* and *[DOWN]* until the top row of the display 'Tilt' flashes. Press *[ENTER]* to open this menu item. Use the buttons *[UP]* or *[DOWN]* to adjust the desired home position.

When the display shows the desired value press *[ENTER]* to confirm the setting and then *[MODE/ESC]* to change to the next menu item. To change the menu item without making changes, press *[MODE/ESC]*.

7.9 Menu overview (settings menu)

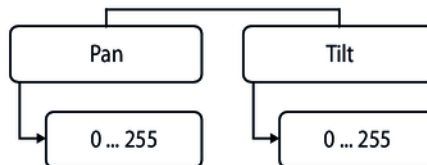

7.10 Functions in 14-channel DMX mode

Channel	Value	Function
1	0 ... 255	Rotation (0° up to the maximum value of the Pan area: 180°, 270° or 540°)
2	0 ... 255	Inclination (0° up to the maximum value of the Tilt area: 90°, 180° or 270°)
3	0 ... 255	Movement speed (fast to slow)
4	0 ... 255	Intensity Red (0 % to 100 %), if channel 8 = 0 ... 127
5	0 ... 255	Intensity Green (0 % to 100 %), if channel 8 = 0 ... 127
6	0 ... 255	Intensity Blue (0 % to 100 %), if channel 8 = 0 ... 127
7	0 ... 255	Intensity White (0 % to 100 %), if channel 8 = 0 ... 127
8	Preprogrammed light effects	
	0 ... 15	No light effect
	16 ... 31	Light effect 1
	32 ... 47	Light effect 2

Channel	Value	Function
	48 ... 63	Light effect 3
	64 ... 79	Light effect 4
	80 ... 95	Light effect 5
	96 ... 111	Light effect 6
	112 ... 127	Light effect 7
	128 ... 143	Light effect 8 (colour setting with channel 4 to 7).
	144 ... 159	Light effect 9 (colour setting with channel 4 to 7).
	160 ... 175	Light effect 10 (colour setting with channel 4 to 7).
	176 ... 191	Light effect 11 (colour setting with channel 4 to 7).
	192 ... 207	Light effect 12 (colour setting with channel 4 to 7).
	208 ... 223	Light effect 13 (colour setting with channel 4 to 7).
	224 ... 239	Light effect 14 (colour setting with channel 4 to 7).
	240 ... 255	Light effect 15 (colour setting with channel 4 to 7).

Channel	Value	Function
9	0 ... 255	Preprogrammed effects speed (from slow to fast)
10	0 ... 255	Dimmer (0 % to 100 %)
11	Shutter	
	0 ... 19	Closed
	20 ... 24	Open
	25 ... 64	Strobe effect 1 from fast to slow
	65 ... 69	Open
	70 ... 84	Strobe effect 2 (fast on, slow off), from fast to slow consecutively
	85 ... 89	Open
	90 ... 104	Strobe effect 3 (slow on, fast off), from fast to slow consecutively
	105 ... 109	Open
	110 ... 124	Strobe effect 4 (random), from fast to slow consecutively
	125 ... 129	Open

Channel	Value	Function
	130 ... 144	Strobe effect 5 (random, fast on, slow off), from fast to slow consecutively
	145 ... 149	Open
	150 ... 164	Strobe effect 6 (random, slow on, fast off), from fast to slow consecutively
	165 ... 169	Open
	170 ... 184	Strobe effect 6 (Pulse series), pulse interval increasing
	185 ... 189	Open
	190 ... 204	Strobe effect 8 (Pulse series with random frequency), from fast to slow consecutively
	205 ... 209	Open
	210 ... 224	Strobe effect 9 (single pulses), from fast to slow consecutively
	225 ... 229	Open
	230 ... 244	Strobe effect 6 (inverted Pulse series), pulse interval increasing
	245 ... 255	Open
12	0 ... 255	Optical zoom, large to small

Channel	Value	Function
13	Special settings	
	0 ... 9	Without function
	10 ... 14	Rotation and inclination interruption
	15 ... 49	Without function
	50 ... 54	Rotation position reset
	55 ... 59	Inclination position reset
	60 ... 64	Optical zoom reset
	65 ... 69	Without function
	70 ... 74	All functions reset
	75 ... 79	Without function
	80 ... 84	Inversion of rotation and inclination direction
	85 ... 89	Inversion of rotation direction
90 ... 94	Inversion of inclination direction	

Channel	Value	Function
	95 ... 99	Cancel inversion of rotation direction
	100 ... 104	Cancel inversion of inclination direction
	105 ... 109	Cancel inversion of rotation and inclination direction
	110 ... 114	Movement speed normal
	115 ... 119	Movement speed fast
	120 ... 124	Movement speed slow
	125 ... 129	Maximum fan speed
	130 ... 134	Automatic fan speed control depending on device temperature
	135 ... 139	Dimmer speed fast
	140 ... 144	Dimmer speed slow
	145 ... 255	Without function
14	Preprogrammed movement pattern	
	0 ... 7	No movement

Channel	Value	Function
	8 ... 23	Movement pattern 1
	24 ... 39	Movement pattern 2
	40 ... 55	Movement pattern 3
	56 ... 71	Movement pattern 4
	72 ... 87	Movement pattern 5
	88 ... 103	Movement pattern 6
	104 ... 119	Movement pattern 7
	120 ... 135	Movement pattern 8
	136 ... 151	Movement pattern 1 with sound control
	152 ... 167	Movement pattern 2 with sound control
	168 ... 183	Movement pattern 3 with sound control
	184 ... 199	Movement pattern 4 with sound control
	200 ... 215	Movement pattern 5 with sound control

Channel	Value	Function
	216 ... 231	Movement pattern 6 with sound control
	232 ... 247	Movement pattern 7 with sound control
	248 ... 255	Movement pattern 8 with sound control

7.11 Functions in 29-channel DMX mode

Channel	Value	Function
1	0 ... 255	Rotation (0° up to the maximum value of the Pan area: 180°, 270° or 540°)
2	0 ... 255	Fine adjustment for rotation (pan)
3	0 ... 255	Inclination (0° up to the maximum value of the Tilt area: 90°, 180° or 270°)
4	0 ... 255	Fine adjustment for inclination (tilt)
5	0 ... 255	Movement speed (fast to slow)

Channel	Value	Function
6	0 ... 255	Intensity Red (0 % to 100 %), LED group 1 (↪ 'LED groups' on page 68)
7	0 ... 255	Intensity Green (0 % to 100 %), LED group 1
8	0 ... 255	Intensity Blue (0 % to 100 %), LED group 1
9	0 ... 255	Intensity White (0 % to 100 %), LED group 1
10	0 ... 255	Intensity Red (0 % to 100 %), LED group 2
11	0 ... 255	Intensity Green (0 % to 100 %), LED group 2
12	0 ... 255	Intensity Blue (0 % to 100 %), LED group 2
13	0 ... 255	Intensity White (0 % to 100 %), LED group 2
14	0 ... 255	Intensity Red (0 % to 100 %), LED group 3
15	0 ... 255	Intensity Green (0 % to 100 %), LED group 3
16	0 ... 255	Intensity Blue (0 % to 100 %), LED group 3
17	0 ... 255	Intensity White (0 % to 100 %), LED group 3
18	0 ... 255	Intensity Red (0 % to 100 %), LED group 4

Channel	Value	Function
19	0 ... 255	Intensity Green (0 % to 100 %), LED group 4
20	0 ... 255	Intensity Blue (0 % to 100 %), LED group 4
21	0 ... 255	Intensity White (0 % to 100 %), LED group 4
22	Colour setting The adjustable colours and the corresponding numbers are listed on a separate information sheet, which is available online.	
	0 ... 4	Dark
	5 ... 9	Colour 1
	10 ... 14	Colour 2
	15 ... 19	Colour 3
	20 ... 24	Colour 4
	25 ... 29	Colour 5
	30 ... 34	Colour 6

Channel	Value	Function
	35 ... 39	Colour 7
	40 ... 44	Colour 8
	45 ... 49	Colour 9
	50 ... 54	Colour 10
	55 ... 59	Colour 11
	60 ... 64	Colour 12
	65 ... 69	Colour 13
	70 ... 74	Colour 14
	75 ... 79	Colour 15
	80 ... 84	Colour 16
	85 ... 89	Colour 17
	90 ... 94	Colour 18
	95 ... 99	Colour 19

Channel	Value	Function
	100 ... 104	Colour 20
	105 ... 109	Colour 21
	110 ... 114	Colour 22
	115 ... 119	Colour 23
	120 ... 124	Colour 24
	125 ... 129	Colour 25
	130 ... 134	Colour 26
	135 ... 139	Colour 27
	140 ... 144	Colour 28
	145 ... 149	Colour 29
	150 ... 154	Colour 30
	155 ... 159	Colour 31
	160 ... 164	Colour 32

Channel	Value	Function
	165 ... 169	Colour 33
	170 ... 174	Colour 34
	175 ... 179	Dark
	180 ... 201	Automatic gradual colour change in ascending order, from fast to slow
	202 ... 207	Stopping automatic colour change
	208 ... 229	Automatic gradual colour change in descending order, from fast to slow
	230 ... 234	Dark
	235 ... 249	Automatic stepwise colour change in ascending order, from fast to slow
	250 ... 255	Sound-controlled colour change
23	Preprogrammed light effects	
	0 ... 15	No light effect
	16 ... 31	Light effect 1 (colour setting with channel 22).
	32 ... 47	Light effect 2 (colour setting with channel 22).

Channel	Value	Function
	48 ... 63	Light effect 3 (colour setting with channel 22).
	64 ... 79	Light effect 4 (colour setting with channel 22).
	80 ... 95	Light effect 5 (colour setting with channel 22).
	96 ... 111	Light effect 6 (colour setting with channel 22).
	112 ... 127	Light effect 7 (colour setting with channel 22).
	128 ... 143	Light effect 8
	144 ... 159	Light effect 9
	160 ... 175	Light effect 10
	176 ... 191	Light effect 11
	192 ... 207	Light effect 12
	208 ... 223	Light effect 13
	224 ... 239	Light effect 14
	240 ... 255	Light effect 15

Channel	Value	Function
24	0 ... 255	Preprogrammed effects speed (from slow to fast)
25	0 ... 255	Dimmer (0 % to 100 %)
26	Shutter	
	0 ... 19	Closed
	20 ... 24	Open
	25 ... 64	Strobe effect 1 from fast to slow
	65 ... 69	Open
	70 ... 84	Strobe effect 2 (fast on, slow off), fast to slow consecutively
	85 ... 89	Open
	90 ... 104	Strobe effect 3 (slow on, fast off), fast to slow consecutively
	105 ... 109	Open
	110 ... 124	Strobe effect 4 (random), fast to slow consecutively
	125 ... 129	Open

Channel	Value	Function
	130 ... 144	Strobe effect 5 (random, fast on, slow off), fast to slow consecutively
	145 ... 149	Open
	150 ... 164	Strobe effect 6 (random, slow on, fast off), fast to slow consecutively
	165 ... 169	Open
	170 ... 184	Strobe effect 6 (Pulse series), pulse interval increasing
	185 ... 189	Open
	190 ... 204	Strobe effect 8 (Pulse series with random frequency), from fast to slow consecutively
	205 ... 209	Open
	210 ... 224	Strobe effect 9 (single pulses), from fast to slow consecutively
	225 ... 229	Open
	230 ... 244	Strobe effect 6 (inverted Pulse series), pulse interval increasing
	245 ... 255	Open
27	0 ... 255	Optical zoom, large to small

Channel	Value	Function
28	Special settings	
	0 ... 9	Without function
	10 ... 14	Rotation and inclination interruption
	15 ... 49	Without function
	45 ... 49	Without function
	50 ... 54	Rotation position reset
	55 ... 59	Inclination position reset
	60 ... 64	Optical zoom reset
	65 ... 69	Without function
	70 ... 74	All functions reset
	75 ... 79	Without function
	80 ... 84	Inversion of rotation and inclination direction
85 ... 89	Inversion of rotation direction	

Channel	Value	Function
	90 ... 94	Inversion of inclination direction
	95 ... 99	Cancel inversion of rotation direction
	100 ... 104	Cancel inversion of inclination direction
	105 ... 109	Cancel inversion of rotation and inclination direction
	110 ... 114	Movement speed normal
	115 ... 119	Movement speed fast
	120 ... 124	Movement speed slow
	125 ... 129	Maximum fan speed
	130 ... 134	Automatic fan speed control depending on device temperature
	135 ... 139	Dimmer speed fast
	140 ... 144	Dimmer speed slow
	145 ... 255	Without function
29		Preprogrammed movement pattern

Channel	Value	Function
	0 ... 7	No movement
	8 ... 23	Movement pattern 1
	24 ... 39	Movement pattern 2
	40 ... 55	Movement pattern 3
	56 ... 71	Movement pattern 4
	72 ... 87	Movement pattern 5
	88 ... 103	Movement pattern 6
	104 ... 119	Movement pattern 7
	120 ... 135	Movement pattern 8
	136 ... 151	Movement pattern 1 with sound control
	152 ... 167	Movement pattern 2 with sound control
	168 ... 183	Movement pattern 3 with sound control
	184 ... 199	Movement pattern 4 with sound control

Channel	Value	Function
	200 ... 215	Movement pattern 5 with sound control
	216 ... 231	Movement pattern 6 with sound control
	232 ... 247	Movement pattern 7 with sound control
	248 ... 255	Movement pattern 8 with sound control

LED groups

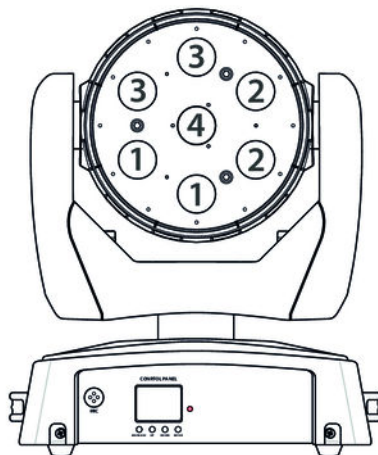

8 Technical specifications

Number of DMX channels	14 or 29 channels, depending on operating mode
Illuminant	7 four-colour LEDs (RGBW, 20 W each)
Dispersion angle	15°
Maximum rotation angle (pan)	540°
Maximum inclination angle (tilt)	270°
Dimmer	electronic, 0 100 %
Power consumption	185 W
Operating supply voltage	AC 230 V ~ , 50 Hz
Fuse	5 mm × 20 mm, 5 A, 250 V, fast-acting
Dimensions (W× H ×D)	330 mm× 230 mm× 380 mm
Weight	8.7 kg

9 Plug and connection assignments

Introduction

This chapter will help you select the right cables and plugs to connect your valuable equipment so that a perfect light experience is guaranteed.

Please take our tips, because especially in 'Sound & Light' caution is indicated: Even if a plug fits into a socket, the result of an incorrect connection may be a destroyed DMX controller, a short circuit or 'just' a not working light show!

DMX connections



The unit offers a 3-pin XLR socket for DMX output and a 3-pin XLR plug for DMX input. Please refer to the drawing and table below for the pin assignment of a suitable XLR plug.

Pin	Configuration
1	Ground, shielding
2	Signal inverted (DMX-, 'cold signal')
3	Signal (DMX+, 'hot signal')

10 Troubleshooting



NOTICE!

Possible data transmission errors

For error-free operation make use of dedicated DMX cables and do not use ordinary microphone cables.

Never connect the DMX input or output to audio devices such as mixers or amplifiers.

In the following we list a few common problems that may occur during operation. We give you some suggestions for easy troubleshooting:

Symptom	Remedy
The unit does not work, no light, the fan does not run	Check the mains connection and the main fuse.
No response to the DMX controller	<ol style="list-style-type: none">1. The 'DMX' LED should flash while data are being transmitted. If it doesn't, check the DMX connectors and cables for proper connection.2. If the 'DMX' LED is not flashing and unresponsive, check the address settings and the DMX polarity.3. Try using another DMX controller.4. Check to see if the DMX cables run near or alongside to high voltage cables that may cause damage or interference to DMX interface circuits.
Display shows ' <i>Lamp Hot</i> '	The LEDs are switched off automatically to prevent overheating. Disconnect the unit from the mains and let it cool down before you turn it on again.

Symptom	Remedy
Display shows <i>'Thermistor Open'</i>	The device was turned off automatically to prevent overheating. Disconnect the unit from the mains and let it cool down before you turn it on again.
Display shows <i>'Thermistor Short'</i>	The device was automatically shut down due to a short circuit. Disconnect the unit from the mains and let it cool down before you turn it on again.

If the procedures recommended above do not succeed, please contact our Service Center. You can find the contact information at www.thomann.de.

11 Cleaning

Optical lenses

Clean the optical lenses, that are accessible from the outside, regularly in order to optimize the light output. The frequency of cleaning depends on the operating environment: wet, smoky or particularly dirty surroundings can cause more accumulation of dirt on the optics of the device.

- Clean with a soft cloth using our lamp and lens cleaner (item no. 280122).
- Always dry the parts carefully.

Fan grids

The fan grids of the device must be cleaned on a regular basis to remove dust and dirt. Before cleaning, switch off the device and disconnect AC-powered devices from the mains. Use a lint-free damp cloth for cleaning. Never use solvents or alcohol for cleaning.

12 Protecting the environment

Disposal of the packaging material



For the transport and protective packaging, environmentally friendly materials have been chosen that can be supplied to normal recycling.

Ensure that plastic bags, packaging, etc. are properly disposed of.

Do not just dispose of these materials with your normal household waste, but make sure that they are collected for recycling. Please follow the notes and markings on the packaging.

Disposal of your old device



This product is subject to the European Waste Electrical and Electronic Equipment Directive (WEEE). Do not dispose with your normal household waste.

Dispose of this device through an approved waste disposal firm or through your local waste facility. When discarding the device, comply with the rules and regulations that apply in your country. If in doubt, consult your local waste disposal facility.

MH-z720 Quad LED Wash Zoom



