



BS 181

SINGLE CHANNEL POWER SUPPLY



QUICK GUIDE

October 2013

This product is designed and manufactured by:

ASL Intercom B.V.
Zonnebaan 42
3542 EG Utrecht
The Netherlands
Tel: +31 (0)30 2411901
Fax: +31 (0)30 2667373
Email: info@asl-inter.com
Web: www.asl-inter.com

1.0 GENERAL DESCRIPTION BS 181

The BS 181 is designed to be a power supply in an ASL intercom system. The intercom line power supply is fully protected against short circuit or

excessive thermal condition and can safely drive up to fifteen BS15 or BS17 beltpacks operating at full power.

2.0 UNPACKING

The shipping carton contains the parts listed below.

- * The BS 181
- * Power cable
- * Spare fuses
- * Quick Guide

If any are missing contact your dealer.

ASL has taken great care to ensure that this product reaches you in flawless condition.

After unpacking the unit please inspect for any physical damage to the unit, and retain the shipping carton and relevant packing materials for use should the unit need returning.

If any damage has occurred, please notify your dealer immediately so that a written claim can be initiated. Please also refer to the warranty section of this quick guide.

3.0 WARRANTY

This unit is warranted by ASL Intercom to the original end-user purchaser against defects in workmanship and materials in its manufacture for a period of one year from date of shipment to the end-user.

Faults arising from misuse, unauthorized modifications or accidents are not covered by this warranty. If the unit is faulty it should be sent in its original packing to the supplier or your local ASL dealer with shipping prepaid.

A note must be included stating the faults found and a copy of the original suppliers invoice.

4.0 MAINS POWER & SAFETY EARTH

WARNING: This appliance must be earthed

The BS 181 may be connected to a mains power outlet (100 - 240 V AC, 50/60 Hz, 60 watts). The outlet should have a clean earth. Avoid using mains power outlets which also power dimmer controlled lighting equipment.

The wires in the mains lead are color coded in accordance with the following code:

- Green/ yellow: Earth / safety ground
- Blue: Neutral
- Brown: Live

In case the colors of the wires in the mains lead do not correspond with the colored markings identifying the terminals in your plug, proceed as follows:

- The wire which is colored green/yellow must be connected to the terminal in the plug which is marked with the letter "E", or by the earth symbol which or is colored green.
- The wire which is colored blue must be connected to the terminal which is marked with the letter "N" or is colored black.

- The wire which is colored brown must be connected to the terminal which is marked with the letter "L" or is colored red.

Safety Earth

For personal safety and proper functioning of the BS 181, the green-and-yellow wire of the mains cord must always be connected to the electrical installation safety earth or ground.

The green-and-yellow wire is internally connected to all exposed metal surfaces.

Powering up

- Make sure that the mains power switch on the left side of the front panel is OFF.
- Connect the power cord to the rear of the station.
- Plug the other end of the power cord into a **properly grounded** mains outlet.
- Switch the unit on with the mains power switch. The green power LED illuminates indicating the BS 181 is active.

5.0 MECHANICAL INSTALLATION

Adequate ventilation must be provided by allowing sufficient space around the sides and rear of the unit to ensure free circulation of air. Forced cooling is not required.

After a period of time the unit will feel warm to the touch. This is quite normal, and should be no cause for alarm.

6.0 FRONT PANEL CONTROLS



1 POWER ON/OFF switch

Mains power push button to switch the internal power supply On or Off

2 POWER LED

This LED illuminates if line power is supplied by the internal power supply.

7.0 REAR PANEL CONTROLS & CONNECTORS



3 INTERCOM LINE connectors

These two XLR-3 connectors are for connecting the user stations, via standard microphone cable.

Pin assignments:

Pin 1: 0 V / ground shield

Pin 2: +30 V power wire

Pin 3: audio wire

4 FUSE holder

A fuse protects the BS 181 against severe internal damage in case of malfunction in the power section. Disconnect the power cord before replacing the fuse. Place the correct fuse in the holder: T 1250 mA (for all mains voltages 100 – 240V AC)

An extra internal fuse is located on the printed circuit board. Replace this fuse with a 4 A type only.

5 MAINS INLET

IEC Mains connector.

8.0 TECHNICAL SPECIFICATIONS BS 181

Switch Mode Power Supply

Mains Voltage Range: 100 -240 V AC, 50-60 Hz

Output Voltage: +30 V DC (+/-5%)

Max. Output Power: 45 watts

BS 181 Dimensions & Weight

Width: 176 mm / Height: 42 mm

Depth: 139 mm / Weight: 900 grams

0 dBu defined as 775 mV into open circuit.

ASL reserves the right to alter specifications without prior notice

For safety instructions and party line concept & cabling, see the BS 181 User Manual.

Go to www.asl-inter.com, section 'Support' and review the referring user manual.

9.0 BLOCK DIAGRAM BS 181

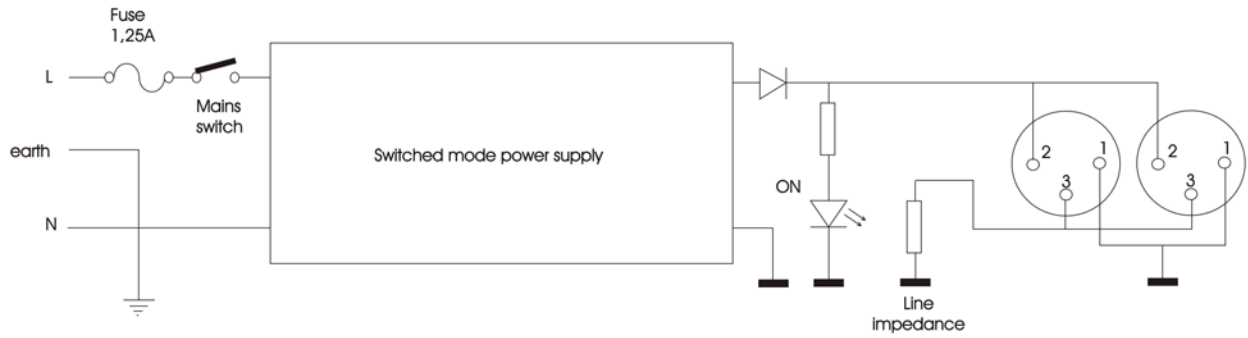

Block diagram BS-181
(C) 1998 ASL-intercom

10.0 SYSTEM CONFIGURATION

