



®



Overdrive Supreme® (ODS) Instrument Amplifiers

V 2.1

Operations Manual

For ODS Models (head and combo)

**ODS-30
ODS-50
ODS-50/100
ODS-100
ODS-150**

Fuchs Audio Technology
407 Getty Ave, Clifton, NJ 07015
(973) 772-4420 (fax) 973-772-4460
Website: www.fuchsaudiotechnology.com
Email: info@fuchsaudiotechnology.com



®

A Note From Andy,

First of all, *Thank You* for purchasing a Fuchs Audio Overdrive Supreme® (ODS) amplifier!

As a guitar player I designed the ODS series of amplifiers to be fabulous instruments for musicians to create music. Each ODS is precision handmade by myself and the staff at Fuchs Audio, built to extremely high standards of excellence using the highest quality components. With over two decades experience in the service, manufacturing, and design of tube audio/music equipment, we at Fuchs Audio are extremely proud of the quality and tremendous musicality of our ODS amplifiers.

Please read this manual carefully. Doing so will allow you full understanding of your ODS controls and operation, thus quickly providing you the tones & performance you want. Your ODS can only perform to its fullest glory by your full understanding of all its features.

Feel free to call or e-mail us (we prefer emails!) with comments & questions about your ODS, or just to find out what's new here at Fuchs Audio.

Lastly, I recommend checking out our web site: www.fuchsaudiotechnology.com, for product/user updates, cool links and other info benefiting our customers.

Sincerely,

Andy Fuchs
President
Fuchs Audio Technology®

Fuchs Audio Technology
407 Getty Ave, Clifton, NJ 07015
(973) 772-4420 (fax) 973-772-4460
Website: www.fuchsaudiotechnology.com
Email: info@fuchsaudiotechnology.com

("Fuchs Audio Technology" & "Overdrive Supreme" are registered trademarks of Fuchs Audio Technology)



®

Overdrive Supreme® (ODS) *Instrument Amplifier*

Table of Contents (by section)

- 1) **Introduction to Fuchs Audio Technology Amplifiers**
- 2) **Please Read before powering up your ODS!**
- 3) **Diagrams- FRONT/REAR panel controls & Footswitches**
- 4) **Front panel Controls & their functions**
- 5) **(A) Rear Panel controls, inputs/outputs, (B) Effects Loop**
- 6) **Footswitches (standard, Artist, Artist Plus)**
- 7) **Biasing your ODS power tubes & other technical info.**
- 8) **Sample tone setting diagrams & notes**
- 9) **Warranty/repair information & mail-in warranty form**

Please note: Many of our ODS amplifiers are custom-made, so not all features appear on all models. This operation manual will indicate features your particular ODS model may or may not have. (such as: 50/100 power switch, Artist footswitch or other options.)

1 Introduction to Fuchs Audio Technology Amplifiers

What makes our products unique?

The recent proliferation of "Boutique" amplifiers, allow guitarists to recognize what audiophiles have known for years, properly designed tube circuits can offer the finest musicality, detail, and sensitivity to playing subtleties of any type amplifier. Anyone who's enjoyed the sweet, responsive character of a well-built tube amplifier realizes you can't model or computer simulate the "organic" qualities, no matter how hard you try. It's like enjoying fresh food or food that's been frozen. Something gets lost in the translation.

We feel our designs go a few steps beyond those of other manufacturers!

In addition to refining our circuit designs and operating points with computer "Spice" modeling, we also spend countless hours tuning our circuits through careful parts selection and refining the internal layout of our products. Details like single-point star grounding of all internal circuits, premium audiophile grade power and output transformers, high speed switching diode power supplies, regulated and buffered DC power supplies for both filaments and high voltage sources, are key elements to producing an amp that has truly unique sonic advantages. All completed amps are compared to reference samples on both test equipment by live players before they are shipped.

Our attention to the power supply and grounding result in an amp with extremely high gain capability, but with a super low noise floor. This reduction in noise and increases in overall circuit clarity makes the selection of components an even more critical element to achieving good tone. While we use many time honored component brands and features like "Orange Drop" Capacitors and/or carbon/metal film resistors, we also use Audiophile grade "Wonder Caps" and unique circuit refinements in many parts of our amplifiers as well.

It's a well-known fact that chassis materials can change the tone of the circuits built into them. We use an aircraft grade T-6 aluminum chassis, which is 1/6" thick, bent at its edges for strength, and when the front and rear panels are attached, forms a strong yet lightweight chassis. Aluminum also provides an excellent heat sink for excess tube, transformer, or regulator heat. Although we install fans in all models, our amps would dissipate plenty of heat even without a fan. The front and rear panels are attached to the chassis pan with pem-nuts, a 1/8" thick assembly formed at both the front and rear of the chassis for rigidity.

A combination of modern and traditional wiring methods

Internal construction in all models is based around a central circuit board, which supports most of the power supply and the amplifiers FX loop, driver and bias circuitry. The balance of the amp is hand wired, with particular attention paid to the preamp section and low-level circuits. All tube sockets are chassis mounted for strength and ease of replacement, in the unlikely event a socket fails. This also keeps tube heat away from the other internal components in the amps.

Our amplifier power supply starts with a high voltage supply, which is rectified using high-speed switching diodes, combining the sonic attributes of a tube rectifier, with the efficiency of solid-state diodes. These produce greater voltages, a more rigid supply that doesn't 'bend' under the stress of loud playing, and they also produce zero heat. This DC supply is highly filtered, using over 200 ufd of power supply filtering, contributing to an amplifier that has a strong voice yet remains loud & clear up to its limits.

Our output stage(s) feature separate bias for each power tube. Although we use premium "matched set" tubes as standard equipment, by individually setting bias, we can obtain maximum power before clipping, extending tube life with better tone. Our power amp driver circuit uses an AC balance trim control, which adjusts the signal balance to the power stage, keeping it linear, producing a clean, strong tone. When driven to clipping, overloading is ultra-smooth, compressing in a sweet way, not at all aggressive or harsh.

Premium Transformers

Our power transformers are designed for highest self-regulation as well as conservative operation, assuring lowest heat and highest reliability. Our output transformers (depending on the model) are premium grade audiophile quality. We use custom built power and output transformers, as well as custom wound chokes by Mercury Magnetics. All amplifiers feature 4 and 8 ohm outputs, grain oriented steel cores, with heavy-duty mounting bells and hardware for maximum roadworthiness.

Buffered FX Loop

Our buffered FX loop features both series and parallel operation. It uses a conventional high-current biased cathode follower, which provides a low-impedance signal source, which is level adjustable and can drive from a pedal level to a rack mount unit cleanly. Two simple switches set series/parallel operation, signal levels from 0db to -20db, easily matching any and all effects, tube or solid state.

Studio Grade Reverb

Our reverb sections feature a solid-state current driven design. By treating the reverb transducer as a current driven device (rather than a voltage driven device like most other designers do), we have produced a quiet, dynamic reverb that sounds as warm and detailed as a tube unit, plus the reliability of solid-state circuitry. This saves on both space, and heat generation within the amp. Our reverb is interfaced through the FX loop, adding warmth to the overall sound. Additional signal clarity is achieved by eliminating the common reverb mixer network used by most other manufacturers.

Our Preamp Circuits

Our preamp circuits form the heart-and-soul of our amplifier tone. Any subtleties lost or masked by preamp stages are truly lost forever. By operating our low-level circuits on a regulated and passively buffered high voltage supply, using a regulated DC supply, we completely eliminate the effects of conventional power supply filtering and decoupling. Audio signals can (and do) appear on power supply sources. Despite large filter capacitors these audio signals do not belong on the pure DC that a tube circuit needs to perform properly. This subtle coupling of signals from adjacent stages can produce a masking of inner detail and potential instability in other high gain circuits. A careful selection of passive parts (resistors and capacitors), as well as the active parts (tubes and/or solid state parts), results in the unique sonic signature our amps are becoming known for. We also use regulated DC filament power supplies, for lowest practical noise floor.

Internal Construction

We proudly can say our products are built better than ever. Our circuit boards are now two-sided extra thick boards, with heavy copper plating and a full solder mask. Our internal layout has been refined to minimize wire runs, lowering the noise floor to the circuit's practical limits. We still chassis mount our tube sockets for maximum strength, durability and serviceability. We hand select our tubes for lowest noise and optimal tone. All passive parts are carefully chosen for both reliability and sonic attributes. Each and every Fuchs amplifier undergoes 20-40 hours of "burn-in" before leaving our shop. This ensures every Fuchs amp is built for the long haul.

2 Please read before powering up your ODS

Please see Panel Diagrams in next section **3** for assistance.

- 1) Inspect to make sure power & pre-amp tubes are intact & snugly seated in their sockets.
- 2) Make certain a speaker (load) is plugged into the correct speaker input jack on the back of the amplifier (4 or 8 ohm). Failure to have a speaker connected to the amp will result in damage to the output tubes! Your ODS is supplied with multiple speaker inputs for various impedances, select the one closest to your speaker(s) impedance.
- 3) Reduce Front PANEL controls (MASTER, GAIN, INPUT, OUTPUT) to moderate levels (approx at 7-9 o'clock positions).
- 4) Install cable into footswitch (either standard or Artist) and then connect into rear panel input marked FOOTSWITCH. (Standard uses ¼" phone jack, Artist/Artist Plus uses 5-pin MIDI jack).
- 5) Install instrument cable from guitar into front panel INPUT
- 6) Be sure both POWER and STANDBY switches (rear panel) are in DOWN position.
- 7) Install power cord to ODS amplifier (AC POWER IN) and to AC power source.
- 8) POWER UP amplifier by: 1) flipping POWER switch UP. WAIT at least 1 minute for tubes to heat up. 2) Flip STANDBY switch UP, amplifier will now operate.
- 9) The Amplifier is now fully on and ready to use. Feel free to adjust all controls as you see fit.
- 10) Provide adequate and unimpeded ventilation.
- 11) Do not expose the unit to drips or splashes.
- 12) Do not to place liquids on the unit.
- 13) Properly ground the unit (i.e. make sure the outlet used is grounded, and ground is not defeated between the outlet and unit).

TO PUT AMP IN STANDBY MODE- Simply flip the STANDBY switch DOWN.

TO PUT AMP IN PLAY MODE- Simply flip the STANDBY switch UP.

TO TURN AMP OFF Flip the STANDBY switch DOWN. We then recommend (as a kindness to the output tubes) waiting at least 1 minute before flipping POWER switch DOWN hence fully shutting the amp down.

3 Diagrams of FRONT & REAR Panels and FOOTSWITCHES

Front Panel



Rear Panel

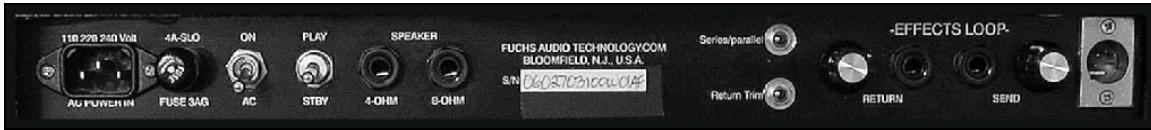

Effects Loop



Standard Footswitch (2-way)



Artist Footswitch (4-way)



Artist Plus Footswitch (6-way)



(Please note that external appearances of footswitches may vary depending on production date. All functions remain the same regardless)

4 Front Panel Controls and Their Functions



Input Jack(s):

Input jack(s), are 1/4" phone plugs, designed for 1-Meg impedance, guitar-level signal. This input will readily accept pedals/effects without any loss in performance. The design of the ODS amplifier is quite flexible, so we first suggest exploring its performance without any effects or pedals initially.

Gain Control:

The gain control sets the input gain for the primary clean preamplifier. The clean channel acts as a preamplifier alone, during clean (non-overdrive) operation. When the amplifier is in overdrive mode, the clean channel functions as a preamp to the overdrive stage. All controls on the primary channel remain operational during overdrive, allowing the overdrive tone to be controlled.

Brite Switch:

The Brite switch operates on the gain control/and is active over about ½ of the input gain control range. From '0' to about midway, it provides a boost to highs, and the effect of the switch decreases beyond the halfway point on the gain control rotation.

Deep Switch:

The deep switch shifts the overall tonality of the amplifier, slightly increasing the low frequencies. This is often useful for single-coil guitars, which sometimes need a low-frequency boost.

Rock/Jazz Switch:

The Rock/Jazz switch alters the operation of the tone controls. The Rock position, gives highest gain, as well as a more aggressive rock type equalization. In the jazz setting, tone is a more neutral/smooth tone. All tone controls work in both modes, however their range and depth of operation is changed.

High Control:

The High control serves 2 functions: (IN)-it adjusts high frequency spectrum. (OUT) the High control engages the mid-boost. This shifts the range of the high control downward, to include more midrange. All tone controls still operate, however the tone will be fatter.

Mid Control:

The Mid control serves 2 functions: (IN) Acts to adjust mid frequencies. (OUT) engages the gain boost. This bypasses all tone controls and allows greater overdrive and gain, on both clean and overdrive modes. This can also fatten sound for Single coil pickups.

Low Control:

This control adjust the low frequency spectrum of your ODS.

The Overdrive Controls (INPUT, OUTPUT)

The overdrive stage, as mentioned above is fed from the clean preamplifier. Two controls effect overdrive: You can increase this internal setting if desired The Overdrive Input (Front panel) sets the amount of distortion content, by adjusting the drive between the two overdrive stages. Overdrive Output acts to balance the volume of the Overdrive channel with the clean channel.

There are no "correct" Overdrive settings, finding the desired tone setting depends on the guitars/pickups used, as well as your own personal tastes. (Note: An internal trimmer pot, factory set at approx 1/3 rotation, sets the amount of signal fed from the clean channel into the overdrive stage's first tube. It also determines the type/quantity of overdrive required, and gain of the preamp tubes. This can be adjusted- please contact us prior to attempting this)

Master Volume:

The master volume adjusts the overall volume of the amp and works in conjunction with the GAIN, INPUT & OUTPUT controls for overall volume of the amplifier. **NOTE: For ODS 50/100 owners, the MASTER control serves to control the 50 or 100 watt output. IN is 50 watt, OUT is 100 watt.**

Accent Control:

The accent control works within the power amp section, reducing negative feedback at higher frequencies. It adds an edge to the overall amplifier tone. It's excellent for cutting through in a band or a recording mix. It can also allow greater ability to selectively make notes feed back and "sing".

Reverb Control:

The reverb control adjusts the level of desired reverb. This control does not turn reverb on or off. To turn on/off reverb, use the reverb control located on the footswitch.

5 (A)-REAR Panel Controls, inputs/outputs, (B)-Effects Loop

(A)-REAR panel Controls/input/output jacks

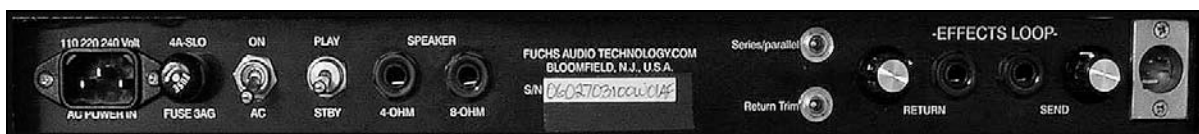

AC power cord input:

Using the supplied 120vac power cord. Connect AC POWER IN on amplifier and to AC power source.

AC power Fuse:

This fuse protects the amplifier if any malfunction occurs. Use **ONLY** stock fuse rating as supplied by factory.

Power On/OFF switch:

Up is ON, DOWN is OFF

Standby switch:

UP is ON, DOWN places the amplifier in STANDBY

Speaker input(s): (You must have a speaker load inputted to the ODS before powering on).

Connect using a 1/4" phone plug to either an outboard speaker cabinet. If you have an ODS Combo amplifier, connect to the combo speaker with supplied wire/1/4" jack. Multiple speaker inputs are installed on your ODS (4, 8 ohm). Connect speaker to input jack that most closely matches your speaker(s) impedance.

Series/Parallel switch:

When in Series-amplifier must have an effect installed or amp will not produce sound. When in Parallel-amplifier will always produce sound. Parallel mixes effect signal with drive signal, which then remains in amplifier.

Return Trim switch:

Sets sensitivity & adjusts sensitivity of return input of the effects loop. Allows tailoring of signal of effect or rack device. If used in series mode, you then depend on outboard effect to mix wet/dry signal balance. Dry signal does not remain in amp.

Return adjustment control:

This allows overall volume adjustment of amp (to set unity gain), thus retaining same volume with/without effect). This control sets the level coming back from your effects, also a secondary means of adjusting return of effect signal. NOTE: The higher gain position is usually used for pedal level signals, and the lower level is for rack type effects. The series parallel switch controls whether the loop is "open" (series) or "closed" (parallel). In series mode the amplifier will produce no sound (except reverb tank output). This is because an effect must be plugged into both the send and return jacks.

Return Input jack:

Connects to OUTPUT FROM your EFFECTS

Send Input jack:

Connects to INPUT TO your EFFECTS.

Send adjustment control:

Adjusts signal level going to effect. Adjust send control so that effect receives maximum amount of signal before distorting.

(B)-Effects Loop



Using the Loop:

When inserting a device like an equalizer, or perhaps a Sonic Maximizer (or similar processor), the loop should be set in series mode. The mix controls on the outboard device can be used to control all effects and the balance between clean and dirty effects.

Side-Chaining Effects:

For maximum signal purity and sound quality, when using effects like digital reverbs and/or effects like an echo or tape delay, the loop can be used in parallel mode. In this case, the effects should be run fully “wet” (no non-processed signals sent through the effect). The send and returns of the loop are set for proper balance of clean/effect and the controls on the effect can be used to trim the tone. This method assures the clean (dry) non processed signal will remain in the amplifier, and not be degraded by the outboard effect.

Amplifier Block Diagram:

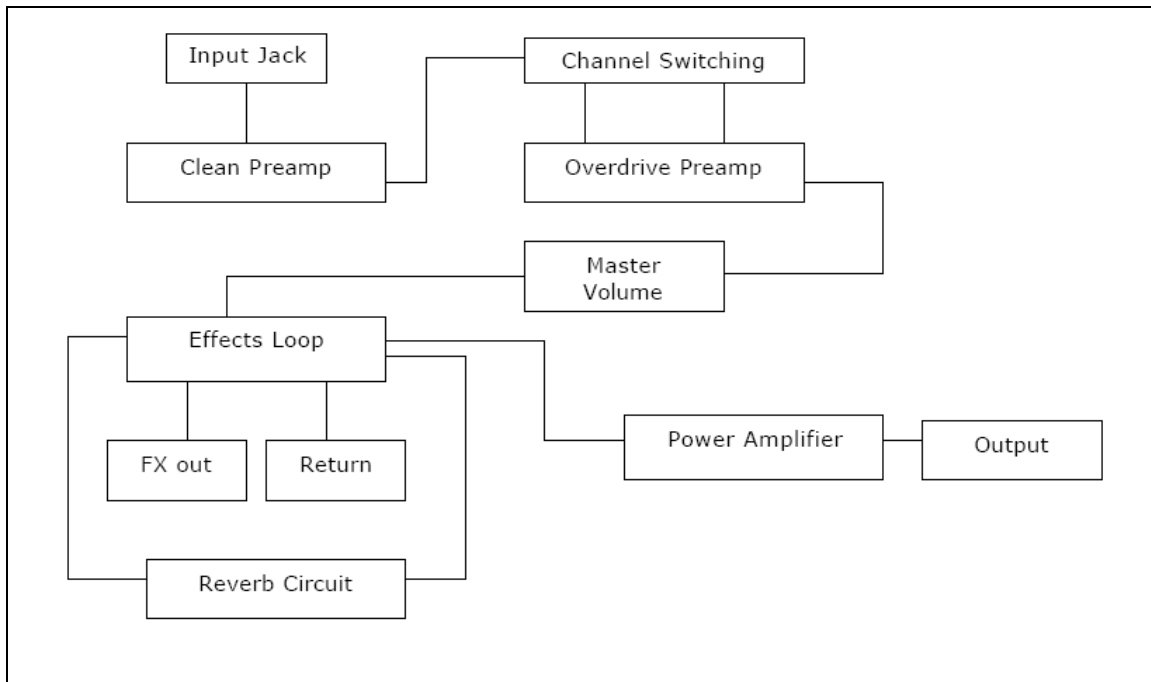

6 Footswitches

Your ODS will be provided with either: a 2 button standard, 4 button “Artist”, or 6 button “Artist Plus” footswitch depending on your purchase selection.

Standard 2-Way footswitch:

Connects via ¼” phone cable (supplied) to rear panel input. Left button controls Clean/Overdrive switching, Right button controls Reverb on/off.



“Artist” 4-Way footswitch:

Connects via 5-pin “MIDI” cable (supplied) to rear panel input. This footswitch allows remote control of 4 functions: mid-boost, gain-boost, overdrive/clean channel switching and reverb on/off. The artist footswitch requires: HIGH, MID, OUTPUT front panel controls be pushed IN (off) for the footswitch to operate these functions. When an LED on the footswitch is lit, that function is ON, except REVERB (Reverb is muted when LED is lit). The amp/controls function normally without Artist footswitch connected.



“Artist-Plus” 6-Way footswitch:

Same connection to ODS as Artist footswitch. The “Artist-Plus” 6 function footswitch provides the same remote functions as Artist yet adds: Effect Loop bypass and System “mute” functions. The artist footswitch requires: HIGH, MID, OUTPUT front panel controls be pushed IN (off) for the footswitch to operate these functions. When an LED on the footswitch is lit, that function is ON, except REVERB (Reverb is OFF when LED is lit). When using loop bypass function, it is important that the loop levels (return/send) be adjust so volume with/without effects loop engaged remains the same. These levels can be intentionally different to permit a level changes (as in rhythm or lead). The main purpose of the Effects Loop is to match pedal or rack level devices to the amp correctly, not to achieve higher amounts of gain boost. The amp/controls function normally without Artist-Plus footswitch connected.



7 Biasing ODS power tubes and other technical info

Biasing and Internal Adjustments:

Part of chassis and circuit board is shown below with the chassis sitting on its transformers, and front panel facing you. There are exposed high-voltages in this chassis, even with the amplifier shut-off! If you are not familiar with tube amplifiers and/or high voltages, do not attempt to remove the chassis from its cabinet or to attempt to service this amplifier. Refer servicing to the factory or to someone with experience servicing these types of amplifiers.

High Internal voltages inside this amplifier can cause harm or Death!

Hum Balance:

Factory set for minimum hum at idle.

AC Balance:

This is factory set for linear clipping at maximum power output, and is set with an oscilloscope for proper adjustment.

Bias Controls:

Each tube is factory set for .030 Volts (30 millivolts) measured on the one-ohm cathode resistors connected to each power tube pin 8. This should be set with the amp cold, then reset after the amp has run for about an hour. Use a reliable digital volt meter for these settings.

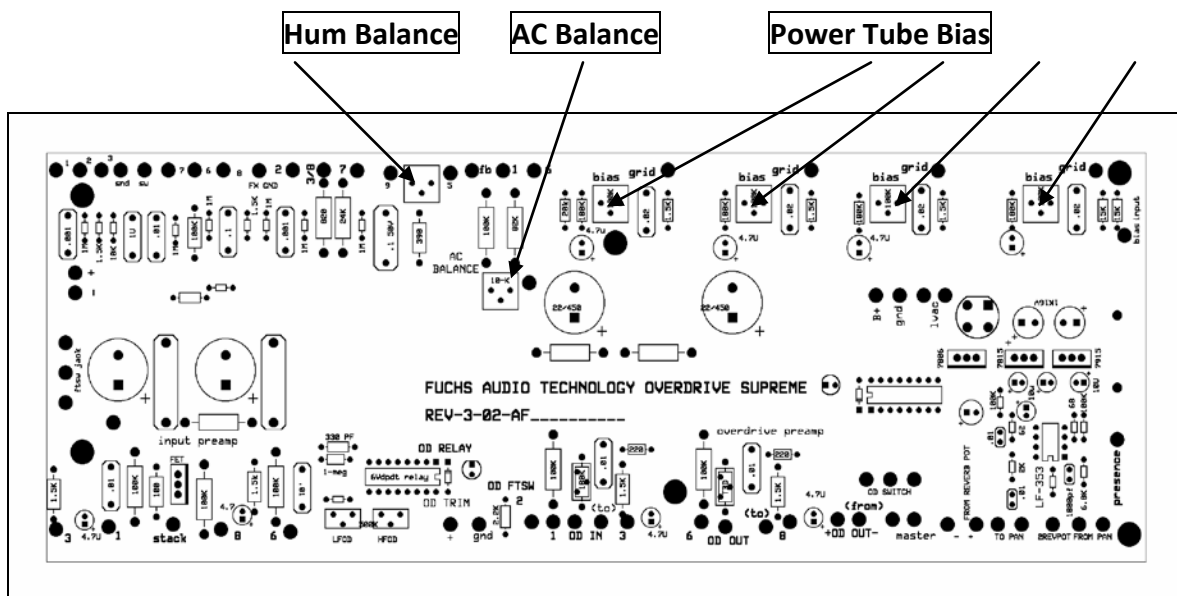

DISCLAIMER: There are exposed Internal high-voltages in this amplifier. Do not attempt to service, repair or conduct tube biasing unless you are qualified to do so. Please contact Fuchs Audio beforehand with questions in this regard. Fuchs Audio takes no responsibility or shall be held liable for any personal harm caused or damage to this amplifier as a result of unauthorized service, repair or internal adjustments made to this amplifier.

8 ODS Sample Setting diagrams & notes (make copies & use!)

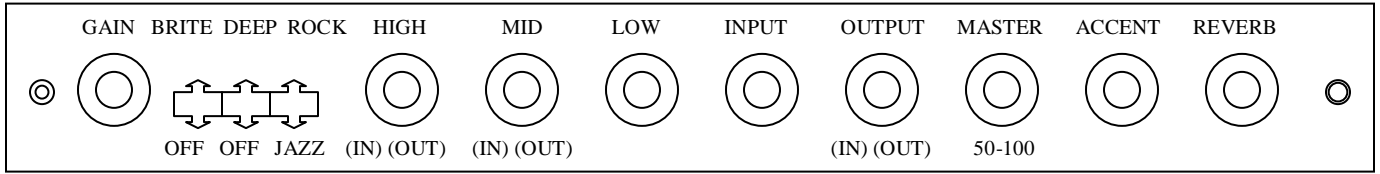

NOTES:

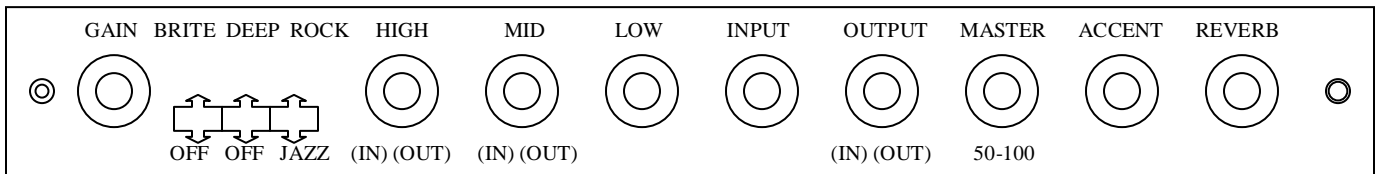

NOTES:

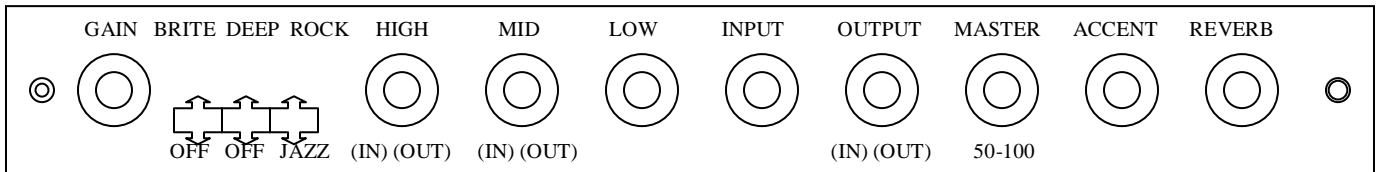

NOTES:



The Fuchs Audio Technology-ODS Warranty

Fuchs Audio Technology® guarantees our products to be free from defective workmanship or material failure for a period of FIVE years (tubes excluded) from date of new purchase to the original purchaser. This does not apply to Fuchs amplifiers that have been tampered with, damaged by shipping carriers, reverse engineered, or modified. This warranty is void if the amplifier is used with power attenuator type devices (Power Soaks, Air Brakes, Hot Plates etc.). Your warranty form/information must be returned to Fuchs Audio Technology® within 30 days of purchase, or your warranty will not be in effect. Fuchs Audio Technology® reserves the right to suspend or terminate the above warranty at our sole discretion, should damage from any of the above limitations and or exclusions be detected upon examination.

Keep the information on this page for your records.
Please mail-in warranty form on next page

FUCHS MODEL: _____

SERIAL NUMBER: _____

OPTIONS INCLUDED: _____

PRODUCTION DATE ___/___/___

TESTED BY: _____ Fuchs Audio Amplification®



®

WARRANTY REGISTRATION FORM

This completed form must be returned to Fuchs Audio Technology within 30 days of purchase along with a copy of your receipt from your authorized dealer.

Please fill in all requested information on this form so we may register you for future warranty repairs or future upgrades, should they become available.

Purchasers Name: _____

Address: _____

City: _____ State: _____ Zip: _____ Country: _____

Phone Number: _____ E-Mail address: _____

Model: _____ Serial Number: _____

Date of Purchase: _____

Dealer Name: _____

Comments:

Please return this form to:

Fuchs Audio Technology

407 Getty Ave, Clifton, NJ 07015

(973) 772-4420 (fax) 973-772-4460

Website: www.fuchsaudiotechnology.com

Email: info@fuchsaudiotechnology.com