



**MB COMBO
OWNER'S MANUAL**

MB SERIES COMBOS

Congratulations!

Your purchase of a new Gallien-Krueger amplifier is surely the result of much careful consideration on your part. For our part, we at Gallien-Krueger are pleased that you chose us, and are determined that you will be a satisfied customer. In choosing a GK amplifier, you now own an amplifier with many unique features which will allow you to create your own distinct sound.

To get the most out of your new purchase, please take a few minutes to read through this manual. If you are in a hurry, we suggest you at least read through the Quick Start section before setting up your new rig. This will help get you started and give you a few quick tips, but is not a substitute for reading the rest of the manual.

Your amplifier should have come with the following items, please check the contents of the box to ensure that you have everything.

Included with your MB Series Combo Amplifier:

Power cord	1
Owner's manual	1
Warranty card	1
Safety instructions sheet	1

If your amplifier did not come with all the items listed, or if you encounter problems while setting up your new equipment, please contact your local dealer or GK as soon as possible.

Gallien-Krueger, Inc.
2234 Industrial Drive
Stockton, CA 95206
phone: (209) 234-7300
fax: (209) 234-8420
Internet: www.gallien-krueger.com
Email: info@gallien.com

We wish you a lifetime of good playing and remember to always have fun!



GK Philosophy

I have never seen the point in doing things the way others have done them. I also have not been very interested in following the latest fad. I'm a Stanford educated engineer who worked my way through school as a musician. Like all musicians, I have lugged amplifiers up stairways and into car trunks, always wondering why these things had to be so heavy, bulky, and hard to handle.

As the principal innovator at GK, our products reflect my attitudes and life experiences. I don't model my designs after other manufacturers' products. Instead, I believe new and old problems are best solved with new solutions. Having taken our own path, GK products enjoy a unique, unmatched sound, allowing you every opportunity to make an original statement.

Having supported my products for over thirty years, I have learned from the story they tell. Gallien-Krueger is a reflection of that story, and has a commitment to support that legacy. Just as the products I created over thirty five years ago are still telling their story, the products we create today will be talking to us tomorrow.

We'll be listening,

A handwritten signature in black ink that reads "Robert Gallien". The signature is written in a cursive, flowing style.

**Robert Gallien
Founder and President**

MB SERIES COMBOS

Table Of Contents

Safety Information _____	4
Quick Start _____	5
Front Panel Controls _____	6
Basic Handling _____	7
Tech Talk _____	8
Specifications _____	9

*All Features and specifications are subject to change without notice





Please read the Safety Information section on page 4 and installation instructions on page 12 before continuing.

Gallien-Krueger
2234 Industrial Drive
Stockton, CA 95206
phone: 209.234.7300
fax: 209.234.8420

email: info@gallien-krueger.com
internet: www.gallien-krueger.com

Warning!

This amplifier is capable of producing high sound pressure levels. Continued exposure to high SPL's can cause damage to your hearing. Always set the volume at a safe listening level or use hearing protection if the unit is operated at higher levels.

	CAUTION RISK OF ELECTRIC SHOCK DO NOT OPEN	
CAUTION: TO REDUCE THE RISK OF ELECTRIC SHOCK, DO NOT REMOVE TOP COVER. NO USER-SERVICEABLE PARTS INSIDE. REFER SERVICING TO QUALIFIED SERVICE PERSONNEL.		
	The lightning flash with arrow head symbol, within the equilateral triangle, is intended to alert the user to the presence of uninsulated "dangerous voltage" within the product enclosure that may be of sufficient magnitude to constitute a risk of electric shock to persons	
The exclamation point within an equilateral triangle, is intended to alert the user to the presence of important operating and maintenance (servicing) instructions in the literature accompanying the appliance.		
WARNING: TO REDUCE THE RISK OF FIRE OR ELECTRIC SHOCK, DO NOT EXPOSE THIS APPLIANCE TO RAIN OR MOISTURE		
CAUTION: TO PREVENT ELECTRIC SHOCK, MATCH WIDE BLADE OF PLUG TO WIDE SLOT, FULLY INSERTED.		
ATTENTION: POUR EVITER LES CHOCS ELECTRIQUES, INTRODUIRE LA LAME LA PLUS LARGE DE LA FICHE DANS LA BORNE CORRESPONDANTE DE LA PRISE ET POUSSER JUSQU'AU FOND.		

MB SERIES COMBOS

Safety Information

Please read all enclosed safety precautions before connecting or operating this product.

Verify Line Voltage and Amperage: Your new amplifier has been factory configured for use with the specific line voltage for your location:
100-120 Volt/60Hz 15 A circuit for USA/Canada.

220-240 Volt/(50/60Hz) 10 A circuit for UK/Australia.

220-240 Volt/(50/60Hz) 10 A circuit for Europe.

100-120 Volt/50Hz 15 A circuit for Japan.

220-240 Volt/50Hz 10 A circuit for Korea.

Proper AC circuit for all other countries.

Connecting the amplifier to a line with specifications other than indicated above can create safety and fire hazard, and may damage the amplifier. If you have any questions about the voltage requirements for your specific model, or about the line voltage in your area, contact your dealer before plugging the unit into a wall outlet.

Verify AC Circuit Capacity Before Use:

The high power output of your amplifier may require heavy current draw under full-load conditions. To insure proper performance and avoid potential safety hazards, we recommend connection to line circuits with amperage specified “as above”. Connecting to the same circuit used by other heavy-power devices, such as high-wattage lights, may cause circuit breakers to trip. It is always a good idea to avoid using any audio equipment on the same AC circuit as equipment with motors, such as air conditioners or refrigerators. This will lessen the possibility of power variation and electrical start-up noise affecting your sound.

Please refer to page 10 for more instructions concerning installation.

AC Power Cord:

To avoid safety hazards, use only the power cord supplied with your unit. If a replacement cord is needed, make certain to use a standard IEC compliant cord. Damaged power cords should be replaced immediately. When setting up, make certain that the AC plug is easily accessible. If you do not intend to use the amplifier for a considerable length of time, disconnect the plug from the AC Mains Socket. Do not use an extension cord.

Earth Grounding Connection:

To prevent electric shock, do not remove the grounding plug on the power cord, or use any plug or extension cord that does not have a grounding plug provided. Make certain that the AC outlet is properly grounded as well. Do not use an adapter plug with this product.

Do Not Open the Amplifier Enclosure:

There are no user serviceable parts inside this product. Opening the amplifier enclosure may present a shock hazard. Modification to the product will void your warranty. If liquid enters the unit, or any metal object such as a paper clip accidentally falls inside the enclosure, disconnect the unit from the AC power source immediately and consult an authorized service station.

Setup:

To insure proper operation and to avoid potential safety hazards, place the unit on a firm, level surface. Do not plug or unplug the instrument or speaker cable while the amplifier power is on.

Heat & Ventilation:

Make sure there is space provided for proper ventilation. Avoid using in extremely hot or cold locations and areas that are exposed to direct sunlight or near heating equipment. Avoid using in moist or high humidity areas.

MB SERIES COMBOS

Quick Start

The MB Series Combos are designed to be simple to operate and all controls have a well defined purpose. These directions will take you through the basics and give you a good start for setting up your sound.

1. Plug it in:

Set the power switch to the off (out) position and connect the supplied power cord from the amplifier AC receptacle to an AC power outlet of proper voltage and power rating (see safety information on page 4 for details).

2. Connect your cabinets (MB210 only):

In addition to its internal speakers, the MB210 can power an external speaker cabinet from the output marked "Speaker" located on the rear panel. The external speaker load must be 8 ohm or above.

3. Initial front panel control settings:

MB210, MB115 and MB212: Set all EQ and boost controls to 12 o'clock. The input gain and master volume should be set to 0 and the contour and horn buttons in the off (out) position.

MB112: Set all EQ controls to 12:00 and the contour in the out position. The input gain should be set to zero.

4. Plug in your bass:

Using an instrument (shielded) cable, connect your bass to the input jack that corresponds to your instrument's output (active or passive) and press the power switch on. If you have active tone controls on your bass, turn all of the controls to the middle or flat position and turn the volume all the way up. If you have conventional, passive tone controls, turn all tone and volume controls all the way up.

5. Level and Master Volume settings:

Set the master volume to 3 o'clock. (MB210, MB115 and MB212 only) While playing, turn the input gain up to the desired volume level.

*Some passive instruments can have output levels similar to active electronics. If the sound is distorted when using the passive input, the active input should be used.

At this point you can experiment with different EQ, contour, horn and boost settings.

MB SERIES COMBOS

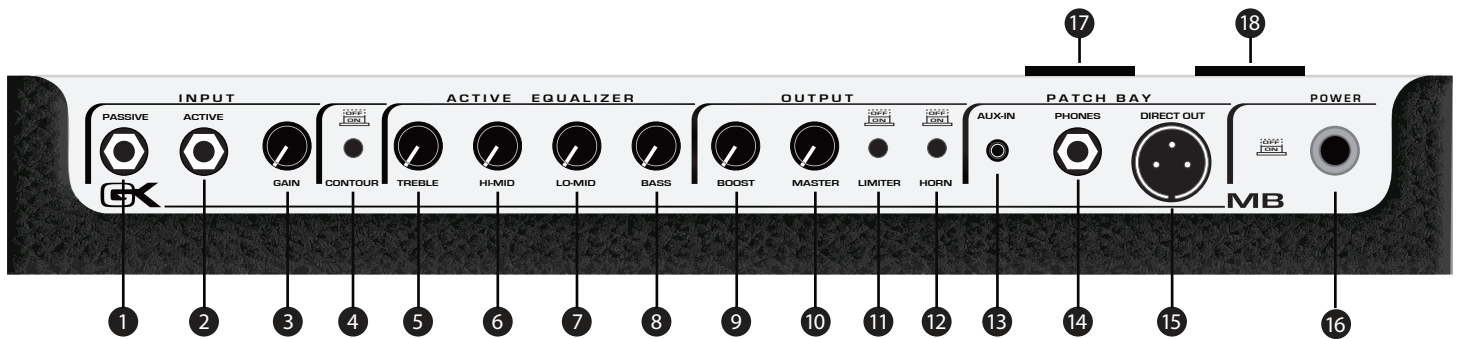

Control Panel Features

- 1 Passive input:** A standard 1/4" input to connect instruments with passive electronics using a shielded cable.
- 2 Active input:** A standard 1/4" input to connect instruments with active or higher output electronics using a shielded cable.
- 3 Gain:** Sets the preamp gain after the input stage. It is used in conjunction with the input pad to optimize the amplifier's headroom.
- 4 Contour:** In the on position the button decreases the mid-range frequencies while boosting low and high frequencies.
- 5 Treble:** Boost and cut at 7 kHz shelving type. Use this control to add or remove edge and definition.
- 6 Hi-Mid:** Boost and cut at 1 kHz. A "Q optimized," band pass type works on lower string harmonics and effects the punch of your sound.
- 7 Low-Mid:** Boost and cut at 250Hz. A "Q optimized" band pass type, effects the main body of your sound.
- 8 Bass:** Boost and cut at 60Hz, shelving type used to control the low end push.
- 9 Boost:** (MB210, MB212 and MB115 only) Adds a post E.Q. gain stage using G.I.V.E. technology adding "growl" as it is turned up.
- 10 Master:** (MB210, MB212 and MB115 only) The master volume is used to control the overall output level in conjunction with boost.
- 11 Limiter:** (MB210, MB212 and MB115 only) When this button is engaged it prevents the power amp from distorting. It is recommended that this feature is used for during high volume applications.
- 12 Horn:** (MB210, MB212 and MB115 only) Activates the high frequency tweeter.
- 13 Aux In:** This 1/8" input for a CD or MP3 player allows the user to monitor an external audio source.
- 14 Phones:** Headphone output. When headphones are connected, the signal sent to the speaker is interrupted.
- 15 Balanced Direct Out:** This electronically balanced output allows a direct connection to a P.A. system.
- 16 Power Switch:** Turns the amplifier on and off. In the on position, the ring surrounding the button will light red during power up then changes to blue, indicating the amp is ready for normal operation. Should the amp experience a fault (over heat or over current) the amp will mute and the ring will light red until the condition is corrected. This LED turns off when the power is switched off. This turns the amp off but it does not completely disconnect the power from the AC mains.

Rear Panel

- 17 Speaker Out: (MB210 only)** Power amp output to an external speaker cabinet. A twist lock Speakon connector allows the connection of a cabinet with a minimum 8 ohm load.
- 18 AC Receptacle:** The detachable power cord connects here.

MB SERIES COMBOS

Installation:

To insure proper operation and to avoid potential safety hazards, place the unit on a firm, level surface.

Ventilation:

Make certain that proper space is provided for ventilation. Consult your dealer for more information. Avoid installation in extremely hot or cold locations, and areas that are exposed to direct sunlight, or near heating equipment. Avoid moist or humid locations.

Packaging:

The carton and packing materials used in shipping your new amplifier were specifically designed to cushion it from the shocks and vibration that occur during transport. We suggest that you save the carton and packing materials for use in shipping, in the event you move, or the amplifier needs repair.

Moving the Unit:

Before moving the unit, be certain to disconnect any interconnection cords with other components, and make sure that you disconnect the unit from the AC outlet.

Cleaning:

When the unit gets dirty, clean only with a dry cloth. Never use benzene, thinner, alcohol, or other volatile cleaning agents. Do not use abrasive cleaners, as they may damage the finish of metal parts. Avoid spraying insecticides near the unit.

Maintenance:

Your new amplifier is rugged. It was built to give you a lifetime of trouble-free operation, if it is operated in accordance with the instructions contained in this manual. The only maintenance required is cleaning. If you are going to move your amplifier around frequently, we recommend a road case to protect it from scratches and road wear.

MB SERIES COMBOS

Tech Talk

Characteristics of the MB Series Combos:

The MB Series is a flexible, state-of-the-art amplifier designed to deliver maximum performance while remaining small, lightweight and simple to operate. This is accomplished through a few, very important features:

- **Class D power supply and power amp.**
- **Four, Bass specific bands of active equalization for precise tone control.**
- **Balanced direct output eliminates the need for a direct box.**

Equalization:

Standard tone controls and graphic equalizers give you plenty of variation, but they don't provide what the instrument really needs. The fact is, graphic equalizers are intended for room equalization. The equalization in Gallien-Krueger amplifiers reflects 40 years of continuous development and refinement.

The GK equalizer is unique to the industry, it's not just a normal four band equalizer, each section is a special circuit optimized to perform a Bass specific job in its range of operation.

These sections are wired in series, adding to one another, to create a tremendously flexible equalizer that sounds natural at any setting. Now it is possible to obtain the sound you desire.

Contour:

The Contour is used to completely revoice the amplifier by tuning between two different shaping circuits, with greatly different responses. With the control engaged, the low end is slightly boosted, the mids are dropped and the high end is pushed up.

“G.I.V.E.” Technology:

The MB210, MB115 and MB212 pre-amp incorporates what we call G.I.V.E (Gate Induced Valve Effect) Technology. We use field effect devices with the gate biased in a way that emphasizes the optimum harmonic content of the signal. Working in conjunction with our unique four band active equalizer and contour, G.I.V.E. technology produces a consistently pleasing bass tone.

Smart Protection Circuitry:

The MB Series protection circuitry constantly monitors for unsafe operating conditions such as short circuits, miss-wired speaker cables, blown speakers, improper ventilation, and incorrect speaker configurations. In addition, protection is provided during power up/down. If the MB Series senses any unsafe operating conditions, the output signal is immediately muted and the power light changes from Blue to Red. The amplifier will remain muted until the fault is removed. Be sure that you are not exceeding the maximum recommend load described in this manual. If the problem persists, contact GK directly for technical advice.

In Closing:

You should now have a thorough understanding of how your new MB Series amplifier works and what advantages it can offer you in getting “your” sound. We thank you for reading the owner's manual and wish you the best of times! Please send us your comments via www.gallien-krueger.com or email us at sales@gallien.com.

MB SERIES COMBOS

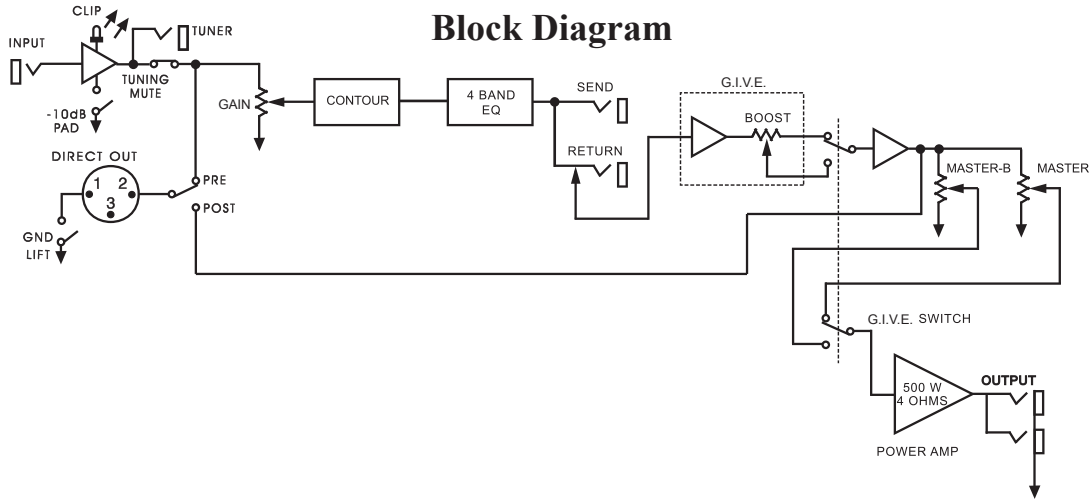

Output Power: 350W @ 8 Ohms
500W @ 4 Ohms

Input Section:

Maximum Input Level 0.6V Rms
With -10dB pad 1.6V Rms
Input Impedance 1M Ohms
Send Output Impedance 220 Ohms
Return Input Impedance 50K Ohms
Tuner Output Impedance 10K Ohms
Direct Output Impedance 500 Ohms

Equalizer:

Bass +/-10dB @ 60Hz
Lo-Mid +6dB/-10dB @ 250Hz
Hi-Mid +6dB/-10dB @ 1KHz
Treble +/-14dB @ 7KHz

Voicing Filters:

Contour +2dB @ 50Hz/
-10dB @ 500Hz/
+3dB @ 7 KHz

Noise: -90 dB reference to 500W/350W, "A" Weighted

Cooling: Variable Speed Fan

Amplifier Protection:

Full short circuit, thermal and RF protection.
Stable into reactive and mismatch loads.
Five second muted warm-up.

Dimensions (HxWxD):

1.75"[44.45mm] x 11"[279.4mm] x 9"[228.67mm].
1 Rack spaces.

Weight:

3 lbs. 12 oz. 1.7 Kg.

Power requirements:

U.S.A./Canada 120V/60Hz.
580W(full power), 75.6W(average power)
Europe 230V/50Hz/60Hz
580W(full power), 75.6W(average power)
Japan 100V/50Hz
580W(full power), 75.6(average power)